



A Maxcess
International
Company

Slitting Accessories and Blade Grinding/Finishing

Blade Guard Attachment

An inexpensive way to minimize the risk of operator injury, this blade guard attaches easily to any Performance Series, C Series, or other knifeholders while maintaining existing minimum slit widths.

659075, Class I
659076, Class II
659077, Class III

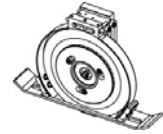

Bench Fixture

Mount the Tidland bench fixture at any angle to make safe and easy off-machine blade changes and adjustments.

130796, Class I
130788, Class II
130822, Class III

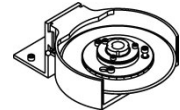

Easy Glider

A cost-effective, easy-to-install solution for faster knifeholder positioning on manual or semi-automatic slitters that are currently equipped with Tidland Performance Series Knifeholders.

662077, Class I
615576, Class II
618966, Class III

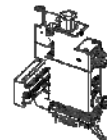

Stainless Steel Protective Glove

Woven metal fibers provide protection from slicing-type hazards.

132084



Coalescing Filter/Air Regulator Kit

The Coalescing Filter/Air Regulator fits between plant air supply and the knifeholder air manifold (single or dual manifold).

520984, single
520985, dual

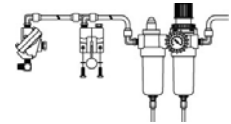

Blade Cartridges with Knife Blades for Shear Slitting – Performance Series

Change blades in seconds with complete replacement assemblies.

	Class I	Class II	Class III
Manual Cartridge Assembly	551430	131061	132872
Automatic Cartridge Assembly	547613	524508	535264

Knife Blades

90mm OD x 60mm ID, D-2	131937	N/A	N/A
90mm OD x 60mm ID x 6mm, D-2	131972	N/A	N/A
150mm OD x 80mm ID, 52-100 (25°)	N/A	128216	N/A
150mm OD x 80mm ID, D-2 (25°)	N/A	128401	N/A
150mm OD x 80mm ID, D-2 super finish (45°)	N/A	133399	N/A
150mm OD x 80mm ID x 10mm, D-2 (5°)	N/A	131973	N/A
200mm OD x 80mm ID, 52-100 (25°)	N/A	N/A	129832
200mm OD x 80mm ID, D-2 (25°)	N/A	N/A	129833
200mm OD x 80mm ID, D-2 super finish (45°)	N/A	N/A	133389
200mm OD x 80mm ID, Powdered Metal	N/A	N/A	501835

Technical Documentation

Installation, Operation and Maintenance manuals for Tidland Performance Series Knifeholders

Performance Series Manual Knifeholder	557416
Performance Series Automatic Knifeholder	557417
Performance Series Crush Knifeholder	612075

Blade Grinding and Finishing

- Correct blade sharpness is essential for shear and crush slitting operations.
- To reduce chipping and rapid dulling of blades, it is important to remove burred edges.
- Grind the blade edge as smooth as possible to avoid dust formation during the slitting process.
- **Before putting blade into operation**, install the blade and set up the knifeholder at the anvil ring. Manually rotate the blade against the anvil in the reverse direction for a few revolutions. This will help deburr the blade after grinding and provide a smooth slitting edge.

Suggested Blade Grinding Procedure			
Step	Procedure	Wet/Dry	Grit/Hardware
1	If required, grind to remove chips, restore roundness, etc.	Wet	46/60 med/soft
2	Rough grind blade edge	Wet	100 medium
3	Finish grind blade edge	Wet	180 med/hard
4	Deburr	Dry (hand)	Oilstone

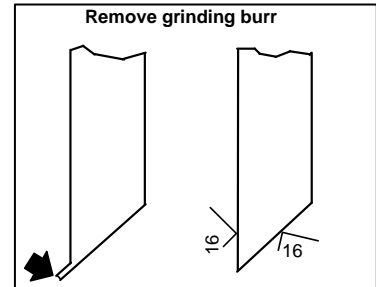

Knife Blades – Shear

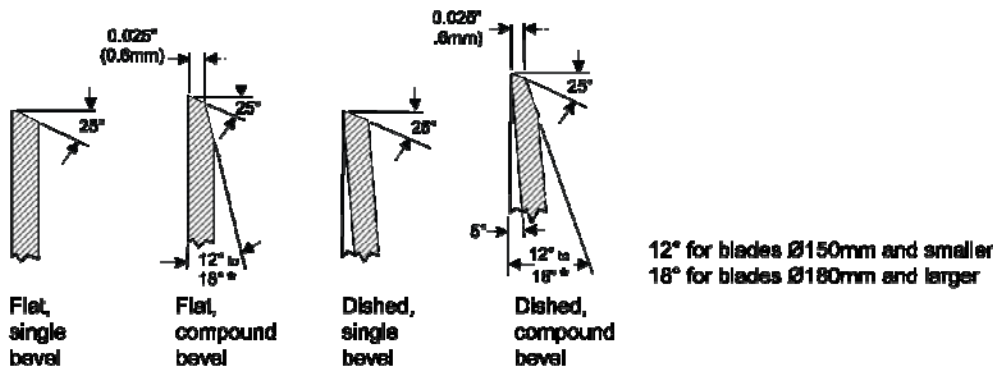

Anvil Rings – Shear

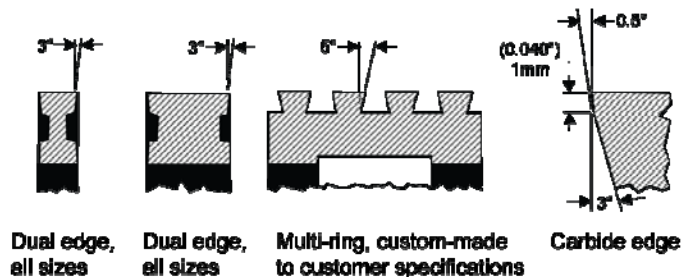

All rights reserved. No part of this publication may be reproduced, transmitted, transcribed, stored in a retrieval system, or translated into any language in any form by any means without the written permission of Tidland Corporation.



Tidland Corporation
2305 SE 8th Avenue
Camas, WA 98607 USA
Phone: 1-800-426-1000
1-360-834-2345
Fax: 1-360-834-5865
E-mail: tidland@tidland.com
Web: www.tidland.com

Maxcess Europe
Fifestrasse 1, D-65779
Kelkheim/Ts., Germany
Phone: (49) 6195-7002-433
Fax: (49) 6195-7002-933
E-mail: info@maxcess.eu

Maxcess Asia
300 Orchard Road No. 15-05
Orchard Towers
Singapore 238875
Phone: (65) 9620-3883
Fax: (65) 6235-4818
E-mail: asia@maxcessintl.com

©2010 Tidland Corporation Rights reserved to amend technical details without notice 573815 Rev C August 2010



GUIDING · INSPECTION

TENSION CONTROL

SLITTING · WINDING