



FIFE VEO 700

Ensure Web Quality with Digital Inspection

The Fife VEO 700 is our advanced system offering in video-assisted moving-web monitoring inspection.

The VEO 700 uses a camera system with integrated LED strobe lighting, timed to your machine print cylinder, bull gear or printed mark to capture or “freeze” images of a moving web. This allows for the visual inspection of print quality, registration and other print processes by an operator at production speeds.

In addition, the VEO 700 features programmable positioning, job storage, 20:1 zoom function, up to 10 images per second, gamma adjustments and split screen with image freeze. The VEO 700 joins the entry-level VEO 600 in inspection system offerings from Fife.

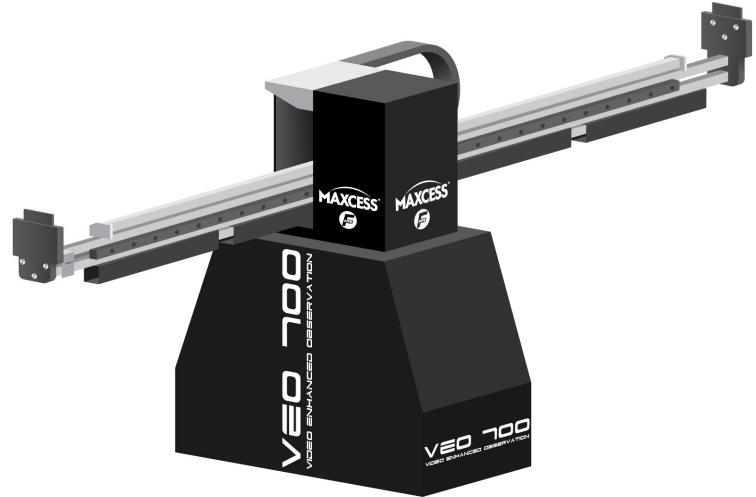

GENERAL SPECIFICATIONS

Product Models

VEO 700-MTZ:
Standard field of view
100 X 75 mm
(3.54 X 2.66 in)

VEO 700-MTZ-EFOV:
200 x 120 mm
(7.87 x 4.72 in)

Enclosure
IP20

Ambient Temperature
0 to 40°C
(32 to 104°F)

Power Supply
110 to 240 VAC
(50 to 60 Hz)

Line Speed

500 m/minute
(1,640 feet/min)

Camera Type
CMOS Imager

Output Resolution
1600 X 900 pixels

Image Capture Rate
Up to 10X per second

Optical Zoom
20X

Strobe Head
LED

Monitor

Standard: 19 in
Optional: 24 in

Positioning Traverse Dual mount max. length
5 m (196 in)

Fully-programmable positioning

Positioning Speed
150 mm/sec
(5.9 in/sec)

User Interface Options
Touchscreen Monitor
Touchpad Remote
Mouse

KEY FEATURES

- Easy to operate
- Graphical user interface
- 19 or 24” LED wide-screen monitor
- Touchscreen monitor, touchpad remote or mouse interface options
- Split-screen and image freeze
- Features gear-tooth sensor, encoder, KT-5 optical mark reader as synchronization inputs
- Synchronized Dual camera optional
- Auto-scan with multiple scan patterns
- Programmable positioning
- Job management
- Motorized back strobe optional

DESIGN FEATURES

EFOV Model

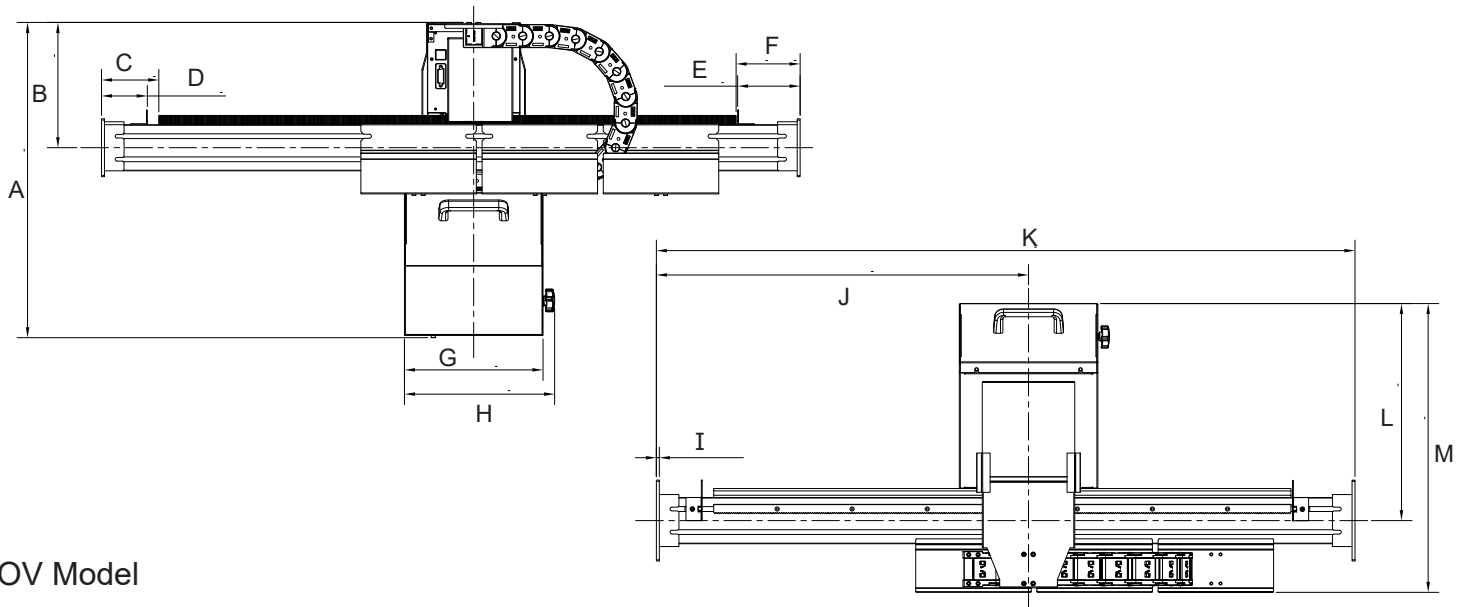

SFOV Model

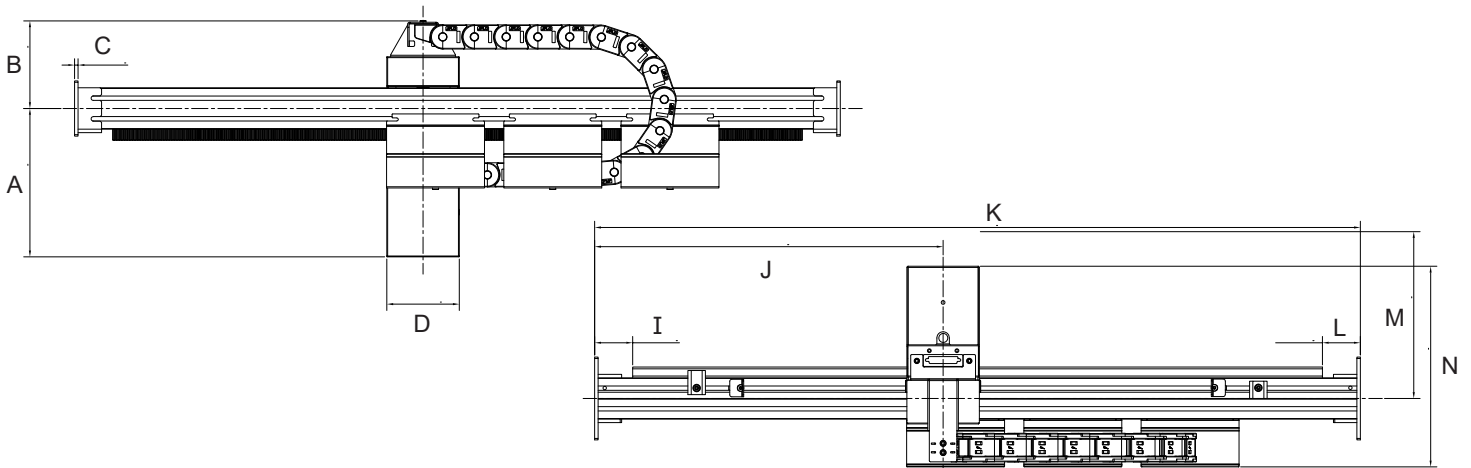

Dimensions

Model	Units	A	B	C	D	E	F	G	H	I	J	K	L	M	N
EFOV	MM	34.13	13.56	6.20	4.96	6.76	6.93	15.00	16.26	0.31	40.29	75.63	23.50	31.27	N/A
	IN	1.344	0.534	0.244	0.195	0.266	0.273	0.591	0.640	0.012	1.586	2.977	0.925	1.231	N/A
SFOV	MM	53.75	31.75	1.25	26.25	N/A	N/A	N/A	N/A	13.75	126.27	277.50	13.75	60.46	72.73
	IN	2.116	1.250	0.049	1.033	N/A	N/A	N/A	N/A	0.541	4.971	10.925	0.541	2.380	2.863



GLOBAL HEADQUARTERS AND AMERICAS

Tel +1.844.MAXCESS
 Fax +1.405.755.8425
 sales@maxcessintl.com
 www.maxcessintl.com

EUROPE, MIDDLE EAST, AND AFRICA

Tel +49.6195.7002.0
 Fax +49.6195.7002.933
 sales@maxcess.eu
 www.maxcess.eu

CHINA

Tel +86.756.881.9398
 Fax +86.756.881.9393
 info@maxcessintl.com.cn
 www.maxcessintl.com.cn

INDIA

Tel +91.22.27602633
 Fax +91.22.27602634
 india@maxcessintl.com
 www.maxcess.in

JAPAN

Tel +81.43.421.1622
 Fax +81.43.421.2895
 japan@maxcessintl.com
 www.maxcess.jp

KOREA, TAIWAN, AND SE EASIA

asia@maxcessintl.com
 www.maxcess.asia

