



The rugged GMA actuator provides the extra thrust you need to handle the most demanding jobs, with shiftable loads up to 3,417 Kg (7,517 lbs). The actuator utilizes a 2.0-amp, 1,560-RPM motor to deliver enough power for any application. This gear-driven actuator also features fast shifting speeds of 52 mm/sec (2.04 in/sec) and standard actuator strokes ranging from 50 to 305 mm (2 to 12 inches).



Ball screw and nut design provides low-friction, efficient operation and eliminates the typical end of stroke sticking and need for actuator limit switches. Compatible with all of Fife's controllers, this actuator is widely used for steering guides, displacement guides, positioner assemblies, slaving, chasing applications and unwind/rewind applications.

GENERAL SPECIFICATIONS

Power Supply

24 VDC ($\pm 25\%$)
Current 7.3 A, max

Certifications

UL61010, CE, CAN/CSA-C22.2,
CB Certificate
IP-52 Protection Class

Temperature Range

0 - 50°C

Stroke

50 mm - 305 mm
(approx. 2 inches to 12 inches)

Mounting Options

Rod End, Clevis, Flange, and
Rectangular

Gearing Ratio

1:1 to 1:8

Maximum Motor RPM

1,560

Maximum Shiftable Load

3,417 Kg 7,517 lbs)

Maximum Design Thrust

2,005 N (451 lbs)

Maximum Shifting Speed

52 mm/sec (2.04 inches/sec)

KEY FEATURES

- Integrated design for easy installation
- Low inertia motor allows for faster actuator speeds
- Integrated Servo-Center
- Belt-driven actuator with a maximum design thrust of 2,005 N (451 lbs)
- Maximum shifting speeds of 130 mm/sec (5.12 inches/sec)
- Standard actuator stroke ranges from 50 to 305 mm (approx. 2 to 12 inches)

DIMENSIONS

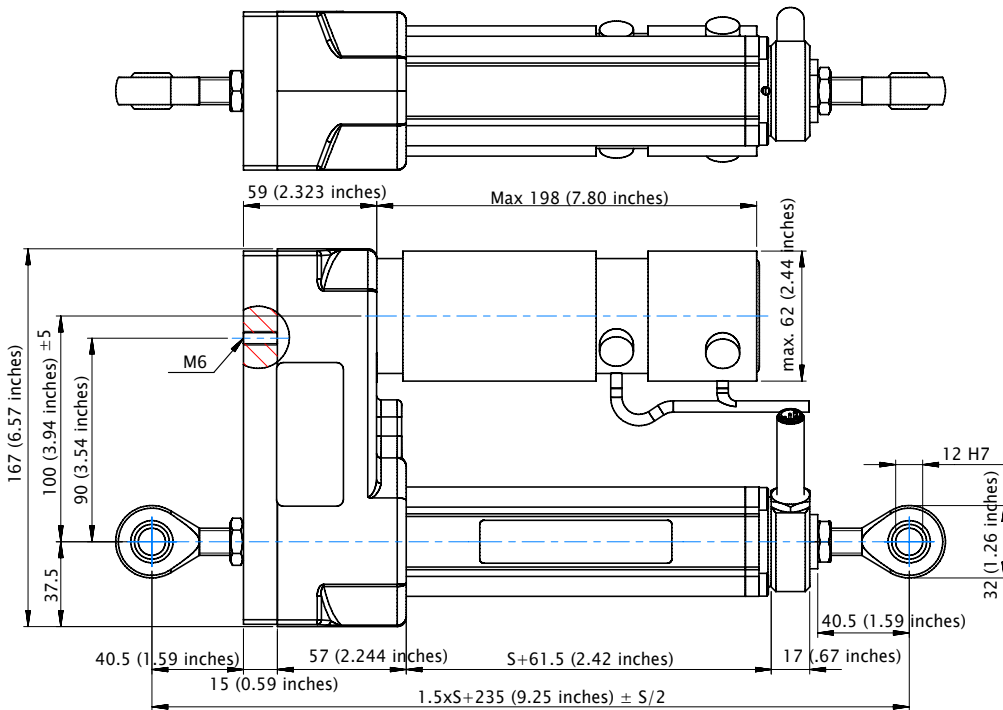

Dimensions shown in mm (inches)

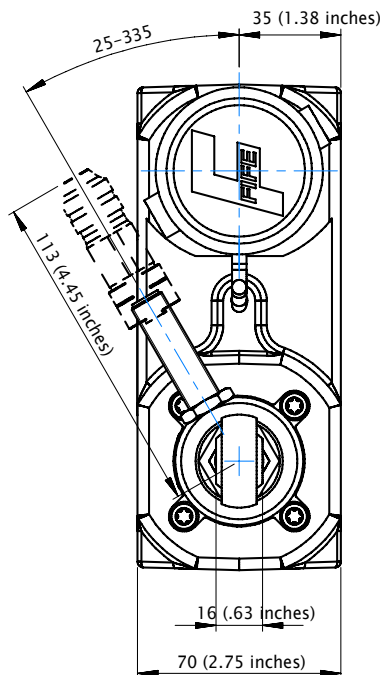

STROKE MM (INCH)
50 (2)
76 (3)
100 (4)
127 (5)
152 (6)
160 (6.3)
178 (7)
203 (8)
229 (9)
254 (10)

CONTROLLER	DP20	DP30	D-MAX
MOTOR AMPS	1.3	1.3 AND 2.0	1.3 AND 2.0

MODEL NUMBER	*MAXIMUM SHIFTABLE LOAD KG (LBS)	MAXIMUM DESIGN THRUST N (LBF)	MAXIMUM ACTUATOR SPEED MM/SEC (IN/SEC)
GMA-1-3	902 (1,983)	529 (119)	38.9 (1.53)
GMA-1-6	1,727 (3,800)	1019 (228)	19.6 (0.77)
GMA-1-8	2,212 (4,867)	1299 (292)	15.2 (0.6)
GMA-3-3	1,386 (3,050)	814 (183)	43.4 (1.71)
GMA-3-6	2,659 (5,850)	1561 (351)	21.6 (0.85)
GMA-3-8	3,417 (7,517)	2006 (451)	16.8 (0.66)

*The standard coefficient of friction is 0.06 for rolling bearings.



NORTH, CENTRAL AND SOUTH AMERICA

Tel +1.405.755.1600
Fax +1.405.755.8425
sales@maxcessintl.com
www.maxcessintl.com

INDIA

Tel +91.22.27602633
Fax +91.22.27602634
india@maxcessintl.com
www.maxcess.in

EUROPE, MIDDLE EAST AND AFRICA

Tel +49.6195.7002.0
Fax +49.6195.7002.933
sales@maxcess.eu
www.maxcess.eu

JAPAN

Tel +81.43.421.1622
Fax +81.43.421.2895
japan@maxcessintl.com
www.maxcess.jp

CHINA

Tel +86.756.881.9398
Fax +86.756.881.9393
info@maxcessintl.com.cn
www.maxcessintl.com.cn

KOREA, TAIWAN AND SE ASIA

asia@maxcessintl.com
www.maxcessintl.asia