

TIDLAND DIGITAL MEASUREMENT SYSTEM

MAXCESS®

MAGPOWER



TIDLAND

PRECISE MEASUREMENT AND DISPLAY OF DISTANCE BETWEEN KNIVES

The affordable Digital Measurement System (DMS) is an extremely accurate and reliable method of measuring slit knife positions. This easy to use system increases accuracy and speeds up repositioning times by replacing manual forms of measurement (i.e. measuring tape) with a location sensor and digital readout.



The DMS is simple to install, requiring standard 110V power plus 5.5 bar (80 psi) minimum filtered air supply. The system is permanently mounted between existing machine frames using two end-mounting blocks supplied with the unit. The electronic display is built-in to the front of the measurement head, or can be remote mounted at any position on the machine.

GENERAL SPECIFICATIONS

Positioning Accuracy

Slit widths \geq 508 mm (20 inches): \pm 0.18 mm (0.007 inch)

Slit widths $<$ 508 mm (20 inches): \pm 0.10 mm (0.004 inch)

Input Supply

110V standard power

5.5 bar (80 psi) minimum

KEY FEATURES

- Extremely accurate knife positioning reduces setup time and eliminates operator error
- For slit widths \geq 508 mm (20 inches) measures knife placement to \pm 0.18 mm (0.007 inch)
- For slit widths $<$ 508 mm (20 inches), measures knife placement to \pm 0.10 mm (0.004 inch)
- Location sensor is unaffected by dust or debris
- Quick and easy retrofit, requires only a few tools to install
- Intuitive controls, simple to operate
- Bright LED readout in metric or english as decimal units or fractions

TIDLAND DIGITAL MEASUREMENT SYSTEM

Installation: Front View

- A 193.3 mm (7-39/64 inches)
- B 160.3 mm (6-3/4 inches)
- C 123.8 mm (4-7/8 inches)
- D 95.3 mm (3-3/4 inches)

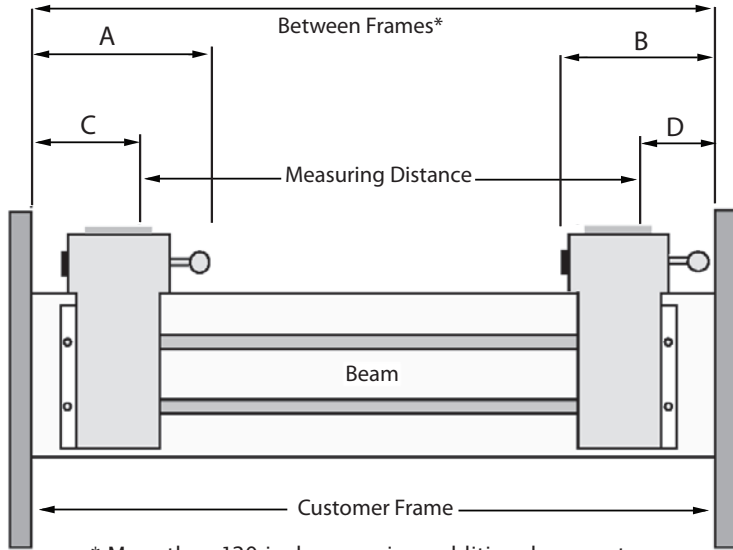

Installation: Side View

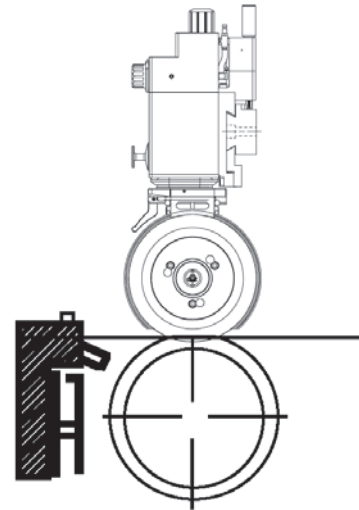

DMS Unit: Side View

- A 87.3 mm (3-7/16 inches)
- B 69.9 mm (2-3/4 inches)
- C 60.3 mm (2-3/8 inches)
- D 11.1 mm (7/16 inch)
- E 177.8 mm (7 inches)

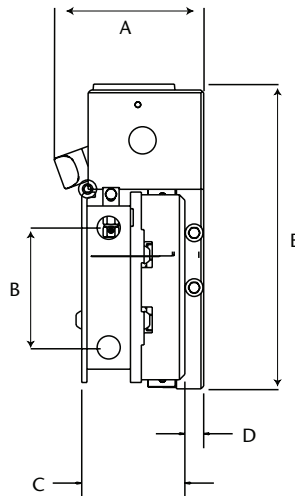

MAXCESS®



NORTH, CENTRAL AND SOUTH AMERICA

Tel +1.360.834.2345
 Fax +1.360.834.5865
 sales@maxcessintl.com
 www.maxcessintl.com

INDIA

Tel +91.22.27602633
 Fax +91.22.27602634
 india@maxcessintl.com
 www.maxcess.in

EUROPE, MIDDLE EAST AND AFRICA

Tel +49.6195.7002.0
 Fax +49.6195.7002.933
 sales@maxcess.eu
 www.maxcess.eu

JAPAN

Tel +81.43.421.1622
 Fax +81.43.421.2895
 japan@maxcessintl.com
 www.maxcess.jp

CHINA

Tel +86.756.881.9398
 Fax +86.756.881.9393
 info@maxcessintl.com.cn
 www.maxcessintl.com.cn

KOREA, TAIWAN AND SE ASIA

Tel +65.9620.3883
 Fax +65.6235.4818
 asia@maxcessintl.com