

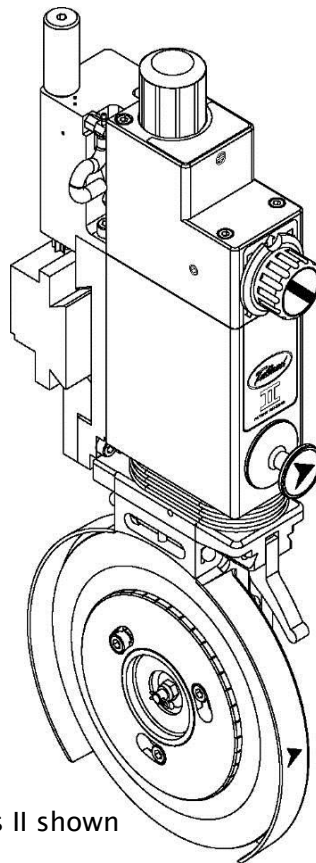

Tidland Performance Series Automatic Knifeholder

Installation, Operation and Maintenance



Class II shown

TABLE OF CONTENTS

Knifeholder Safety	5
Receiving And Unpacking	5
Knifeholder Component Orientation	6
Blade Guard Options	7
360° Blade Guard - Mechanical	7
Adjusting the guard	7
360° Blade Guard - Pneumatic	8
Function Control Knob	10
Installation.....	11
Select Slitting Type	11
Determine Setback.....	11
Recommended Web Penetration for Tangential Slitting Applications	11
Prepare to Mount Guide Bar	12
Determine Space Requirements.....	12
Determine Mounting Dimensions.....	13
Vertical Mounting Dimension – VMD.....	13
Horizontal Mounting Dimension – HMD	13
Install Guide Bar on Support Beam	14
Methods for Measuring Blade Overlap (For Reference Only)	14
Mount Knifeholder	15
Manual Lock.....	15
Pneumatic Lock	16
Adjusting the Gib.....	16
Easy Glider Mount (Linear Bearing)	18
Removing the Knifeholder with an <i>Easy Glider Mount</i>	19
Install Pneumatic System.....	20
Cant Key	22
Selection.....	22
Orientation.....	22
Nomenclature.....	24
Reversing the actuator assembly.....	24
Operation	25
Knifeholder Setup.....	25
Manual Lock	25
Manual Lock	25
Pneumatic Lock.....	26
Maintenance	27
Preventive	27
Guide Bar Cleanup.....	27
Cant Key O-ring.....	28
Blade Cartridge	28
Removing/Reinstalling/Reversing.....	28
Knife Blade	29
Removing/Reinstalling	29
Knifeholder Dovetail: Replacing the O-ring(s).....	30
360° Blade Guard – Class I.....	31
Inspecting and Replacing Parts	31
Troubleshooting.....	32
Slit Quality	32
Knifeholder Performance	33
Knifeholder Disassembly.....	36
Control Body Sub-Assembly Identification.....	37
Guide Bar Mount Assembly	38
Manual Lock, Class I, II and III	38
Pneumatic Lock, Class I, II and III	39
Dovetail Assembly, Class I, II and III	41
Upper Body And Piston Assemblies, Class I	43
Lower Body Assembly, Class I.....	44
Upper/Lower Body and Piston Assemblies, Class II and III.....	45

TABLE OF CONTENTS

Function Control Knob Assembly, Class I, II and III.....	47
Lubrication and Loctite	48
Class I	48
Class II and III	49
Air Flow Schematics	50
Class I	50
Class II and III	51
Knifeholder Parts	52
Class I	52
Automatic Control Body	52
Automatic Blade Cartridge	54
Standard	55
w/ Pneumatic 360° Blade Guard	56
Class II and III	58
Automatic Control Body	58
Automatic Blade Cartridge	60
Standard	60
w/ Pneumatic 360° Blade Guard	62
w/ Mechanical 360° Blade Guard	64
Guide Bar Mount Assemblies.....	66
Manual Lock, Class I, II and III	66
Pneumatic Lock	67
Class I.....	67
Class II and III.....	68
Duraglide.....	69
Class II and III.....	69
Easy Glider Mount, Class I, II and III	70
Cartridge to Control Body Compatibility Chart	71
Blade Grinding and Finishing	72

KNIFEHOLDER SAFETY

Important!

- The Tidland Performance Series Knifeholder intended use is to produce a slit with a driven anvil system. There is no other intended purpose.
- Read and understand all instructions before operating the knifeholder. Failure to follow instructions may cause the knifeholder to function incorrectly and can cause serious injury.
- The knifeholder contains spring-loaded components. While operating the knifeholder, follow all existing plant safety instructions and/or requirements.
- Tidland recommends wearing stainless steel protective gloves when changing or removing the knife blade.
- Sharp knives can cause serious injury. Do not put hands in machines.
- Compliance with federal, state, and local safety regulations is your responsibility. Be familiar with them and always work safely.



Receiving And Unpacking

- Handle and unpack the equipment carefully. Upon arrival, check the shipment against the packing list.
- Promptly report to the carrier any damaged equipment.
- Equipment that will not be installed immediately should be stored in a clean, dry location.
- Be careful to prevent moisture, dust, and dirt from accumulating in storage and installation areas.

KNIFEHOLDER COMPONENT ORIENTATION

1	Depth Control Knob <ul style="list-style-type: none"> • Increase blade cartridge stroke – rotate counterclockwise • Decrease blade cartridge stroke – rotate clockwise
2	Function Control Knob (p. 10) <p>yellow arrow – setup (to position knifeholder) extends knifeholder blade cartridge for knifeholder positioning and locking to guide bar</p> <p>red arrow – retract (non-operating position) completely retracts knifeholder blade cartridge</p> <p>green arrow – run (operating position) extends knifeholder blade cartridge to Depth Control Knob setting</p> <p>⚠ Do not operate knifeholder in the setup position.</p>
3	Knifeholder Control Body
4	Cant Key (blade cartridge angle control)
5	Knifeholder Bellows (prevents foreign matter from entering knifeholder)
6	Safety Lock Pin (shown in locked position)
7	Dovetail (control body to blade cartridge interface)
8	Lock/Unlock Lever (shown in locked position)
9	Blade Cartridge (shown w/ blade guard safety attachment)
10	Knife Blade
11	Guide Bar Mount Assembly (not shown)
12	Air Supply Hose (control body and cartridge)

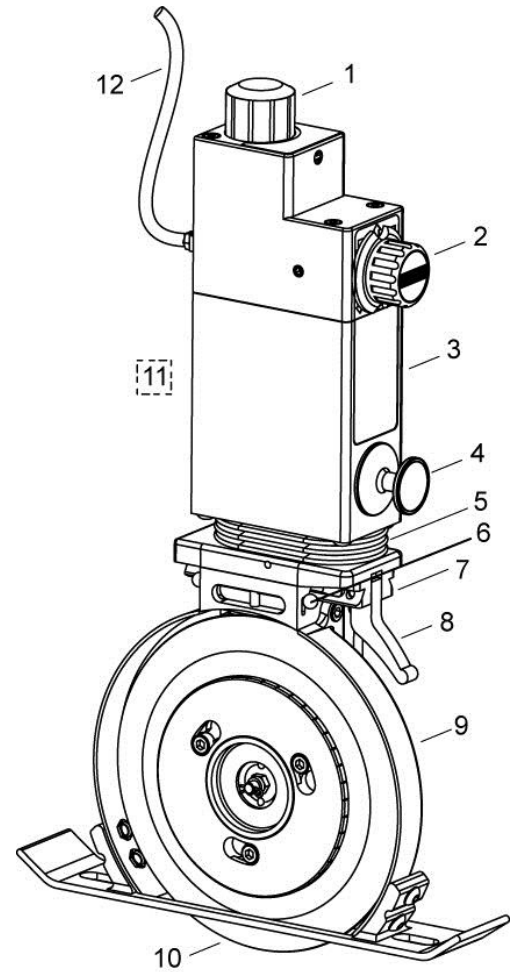

Options:

Class I 360° Blade Guard cartridge; see page 7.

Class II and III 360° Swing Guard Kit; see page 7.

Class II shown

SPECIFICATIONS

Actual speed is dependent on application and material

	Class I	Class II	Class III
Blade Diameter	3.54" (90 mm) *	5.91" (150 mm)	7.87" (200 mm)
Minimum Slit Width	1.0" (25.4 mm) **	2.0" (50.8 mm)	3.0" (76.2 mm)
Designed Maximum Speed*	3500 fpm (1,067 mpm)	5500 fpm (1,677 mpm)	10,000 fpm (3,049 mpm)
Recommended Operating Air Pressure (max. 100 psi)	60-75 psi (4.1-5.2 bar)	60-75 psi (4.1-5.2 bar)	60-75 psi (4.1-5.2 bar)

* If using the Class I 360° Blade Guard cartridge, the minimum blade diameter required to remain CE compliant is 84 mm. CE requirement is <6 mm gap from blade edge to cartridge guard.

** With bellows removed and alternate low profile knife blade fastener

KNIFEHOLDER BLADE GUARD OPTIONS

360° Blade Guard Cartridge - Mechanical

The reversible blade guard covers the blade when the knifeholder is retracted during non-operation and handling.

The guard is held in place by a bracket installed on the guide bar mount and is actuated by the extension of the knifeholder.

The actuator assembly is reversible; it can be moved to the other side of the blade guard strut if you need to change the cut side. See page 24.

Modified blade guards are available for strip blades and wide rim blades.

When the blade cartridge is retracted, the blade is guarded. When the blade cartridge extends, the blade is unguarded.

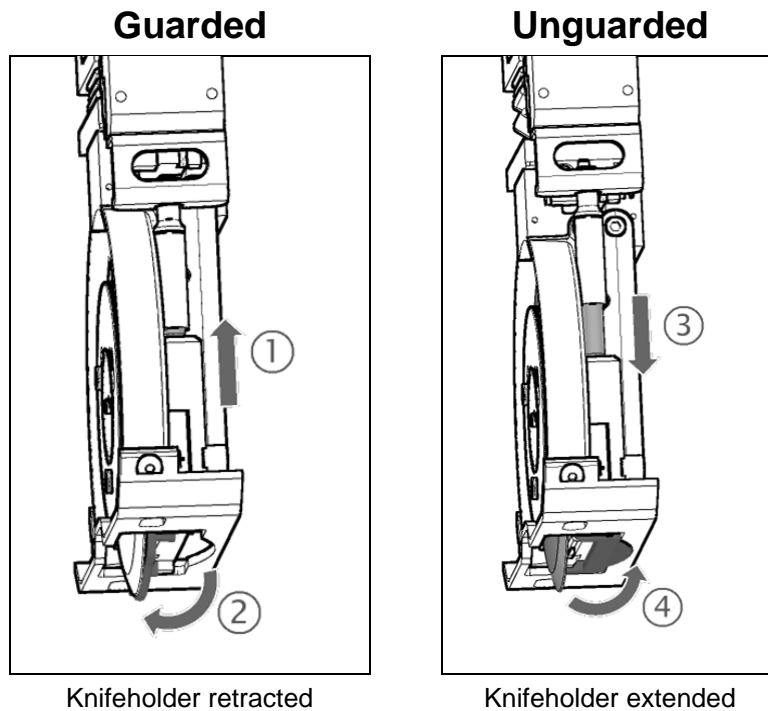

Adjusting the blade guard

To adjust the guard for a closer fit to the knife blade, turn the M5 adjustment set screw (1) clockwise until the guard touches the blade, and then back off one-quarter turn.

The knife blade should spin freely and smoothly on the blade hub and not rub on the guard.

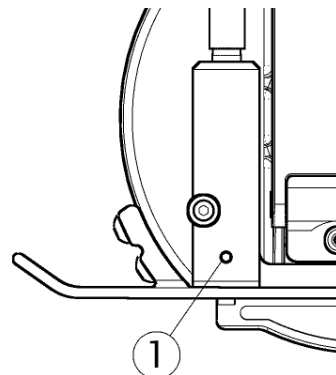

KNIFEHOLDER BLADE GUARD OPTIONS

360° Blade Guard Cartridge - Pneumatic

Class I – 718312

The guard protects the blade during handling and non-operation when air is not supplied to the knifeholder. The guard is to prevent bodily injury during handling or if the product is dropped.

The guard consists of the guard flap, a pneumatic cylinder, a wedge cam, cylinder mount and a return spring that keeps the guard closed when air is not supplied to the cylinder. When air is applied, the cylinder retracts and the flap exposes the blade for the slitting operation. The flap and knifeholder downstroke operation is staged so that the flap never interferes with the anvil ring.

Guarded

During transport, installation or maintenance

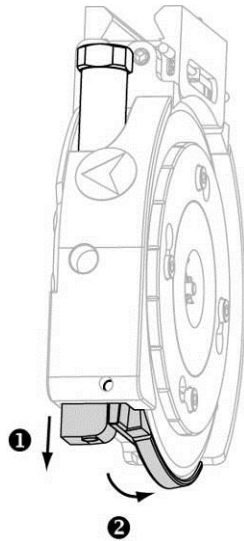

When air is off, or function control knob is in the red (retract) position, the actuator is extended (1) and the blade guard *pivots into the guarded position* (2) as the cartridge retracts.

Unguarded

During slitting operation

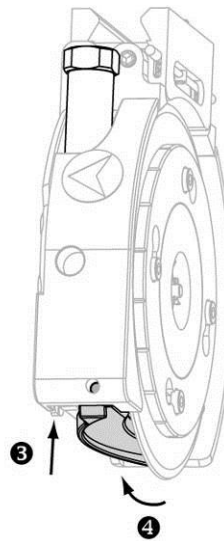

When air is on and the knifeholder function control knob is turned to the setup (yellow) or engage (green) position, the actuator retracts (3) and the blade guard pivots into the unguarded position (4) as the cartridge extends.

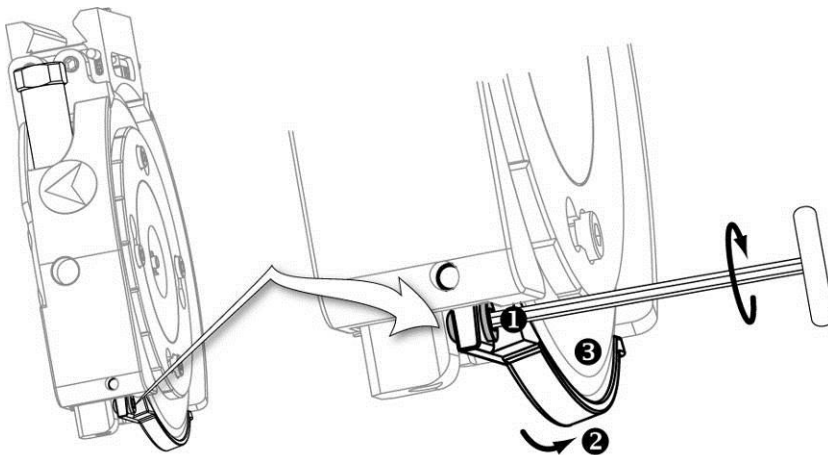

To adjust the flap for a closer fit to the knife blade, turn set screw (1) clockwise until the guard flap (2) just touches the knife blade (3), and then back off one-quarter turn.

The knife blade should spin freely and smoothly on the bearing hub and not rub against the guard flap.

KNIFEHOLDER BLADE GUARD OPTIONS

360° Blade Guard Cartridge - Pneumatic

Class II – 548274

Class III – 548275



This guard does not protect against bodily injury during handling and transport.

Guarded (1)

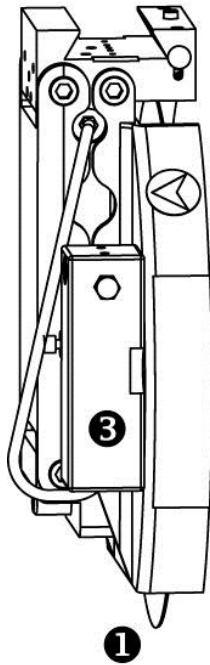

Unguarded (2)

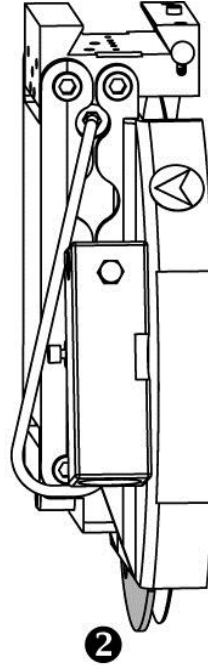



Extending the Blade Guard

- The blade guard is actuated automatically via an internal air circuit interface between the knifeholder and the cartridge.
- The cartridge extends and the blade guard retracts as the supply air is distributed at the setup knob in either the GREEN (RUN) or YELLOW (SETUP) positions.
- When the supply air is turned off at the setup knob RED (RETRACT) position, or at a gang manifold shut off valve, the cartridge retracts and the blade guard extends out of the cartridge.

Flow Control Valve

The flow control valve assembly (3) provides a time delay between cartridge retraction and the blade guard extension. Increase the delay by turning the flow control knob clockwise.

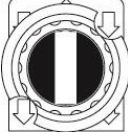
FUNCTION CONTROL KNOB

COLOR	POSITION	FUNCTION
Yellow Arrow	 <p>SETUP</p>	<ul style="list-style-type: none"> • Extends blade cartridge, and then allows half of the available side stroke. • Use when positioning knifeholder blade to anvil rings before lockup to guide bar.
Red Arrow	 <p>STOP (RETRACT)</p>	<ul style="list-style-type: none"> • Reverses sidestroke movement, then retracts blade cartridge. • Use when knifeholder is not in operation. • Use when adjusting depth control knob for overlap. • Use when traversing knifeholder with retracted blade cartridge to new slit position.
Green Arrow	 <p>RUN</p>	<ul style="list-style-type: none"> • Extends blade cartridge, then allows full sidestroke. • Use when operating knifeholder.

INSTALLATION

Select Slitting Type

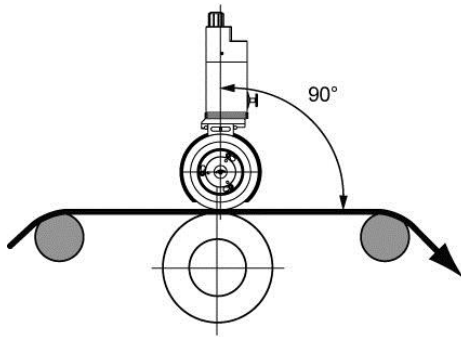

TANGENT

Knifeholder axis should be 90° to web path.
Tangent slitting requires knifeholder setback.

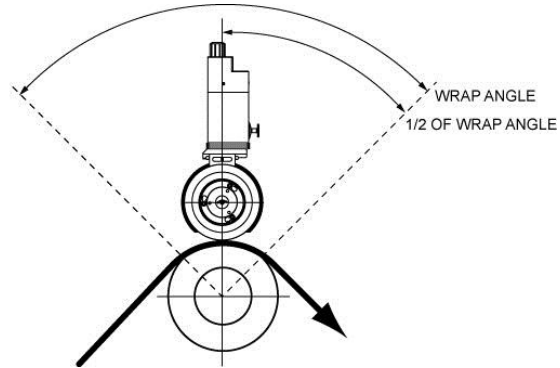

WRAP

Knifeholder axis should bisect the wrap angle.
Knifeholder setback is not required.

Determine Setback

Recommended Knifeholder Setback (For Tangent Slitting Only)

For best slit result, the web must be in contact with the anvil knife ring at the cut point. If the web contacts the top blade ahead of the cut point, the material will tear instead of slitting cleanly.

Geometry shown is based on medium weight kraft paper. For assistance with other web materials, call Tidland Customer Service, 1-800-426-1000.

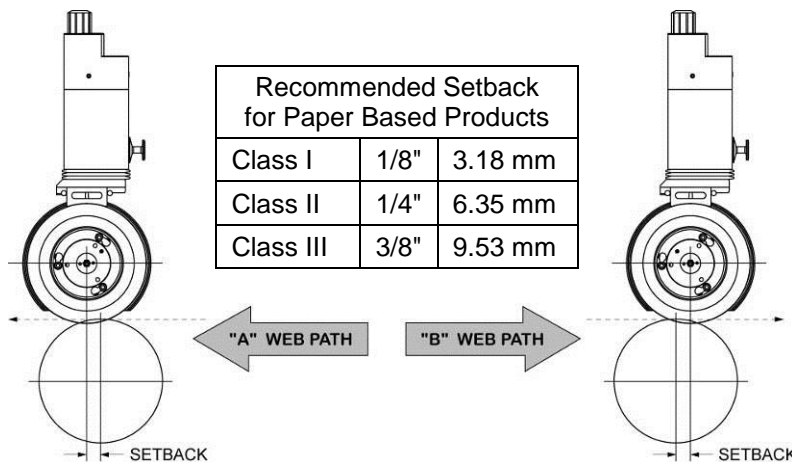

Recommended Web Penetration for Tangential Slitting Applications

To maximize web stability at the cut point, Tidland recommends web penetration by the anvil ring of .015"-.060". Check this measurement by laying a straight edge across the idler rolls to represent the web. Measure how far the anvil ring "penetrates" the plane created by the straight edge.

Thicker web materials require more penetration, while thinner or sensitive materials may require no penetration. Call Tidland Customer Service for assistance. 1-800-426-1000

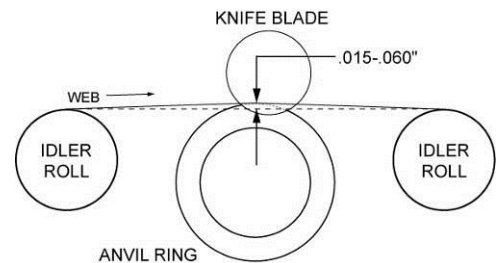

INSTALLATION

Prepare to Mount Guide Bar

Determine Space Requirements

Standard guide bar shown; the Duraglide mounting option is interchangeable with this.

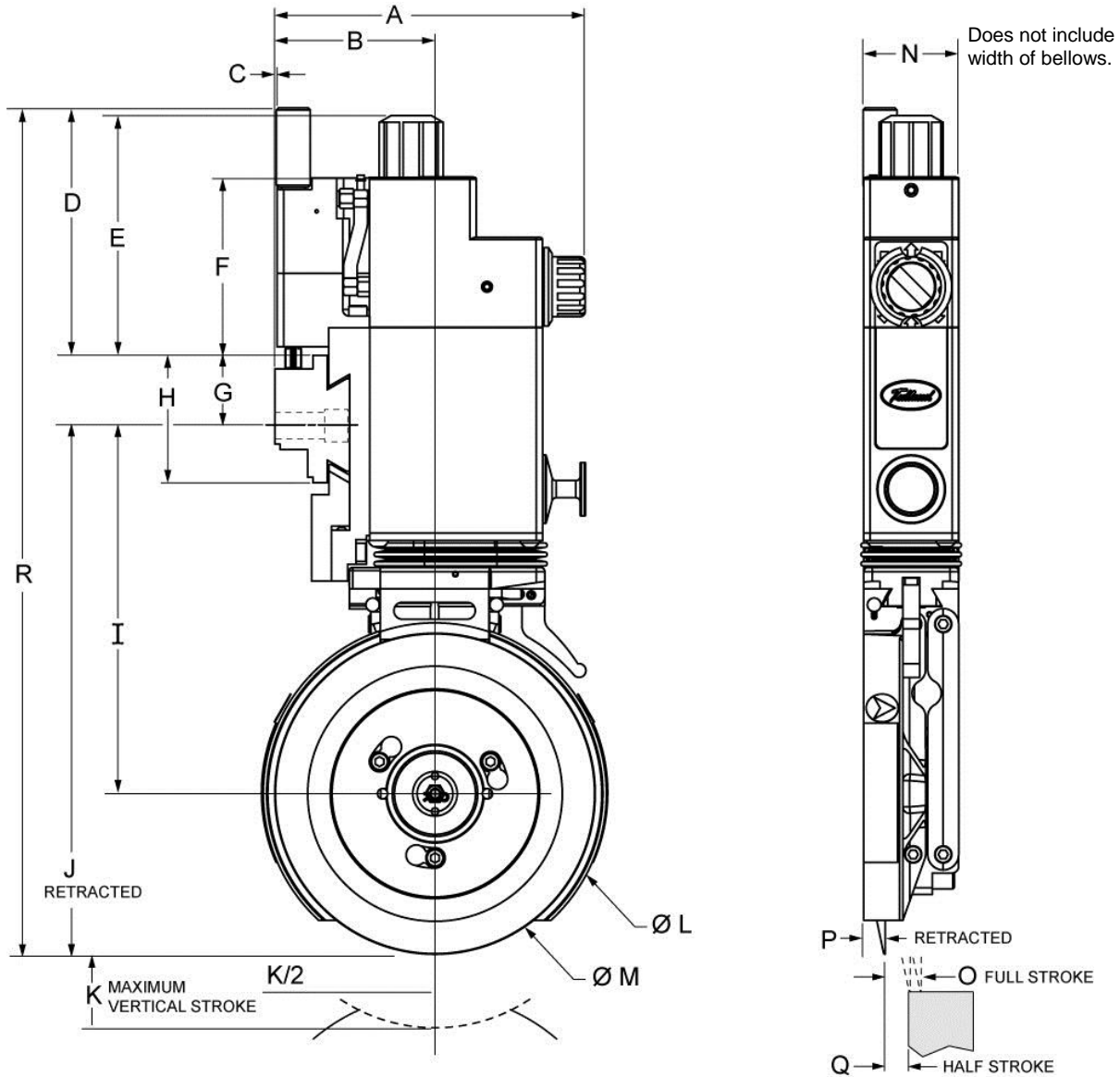

Class II shown

Inches	A	B	C	D	E	F	G	H	I	J	K	L	M	N	O	P	Q	R
Class I	4.74	2.46	0.05	3.86	3.61	2.89	1.04	1.84	4.85	6.62	0.63	3.92	3.54	0.945	0.12	0.19	0.05	11.51
Class II	5.72	2.94	0.03	4.55	4.41	3.26	1.28	2.34	6.79	9.74	1.00	6.33	5.91	1.75	0.16	0.38	0.08	15.57
Class III	6.47	3.46	0.04	4.73	4.56	3.05	1.28	2.34	7.83	11.77	1.00	8.35	7.87	2.76	0.24	0.77	0.12	17.78

Millimeters	A	B	C	D	E	F	G	H	I	J	K	L	M	N	O	P	Q	R
Class I	120.5	62.5	1.4	97.9	91.7	73.4	26.4	46.8	123.2	168.1	16.0	100.0	90	24.0	3.0	4.8	1.3	292.4
Class II	145.3	75.0	0.7	115.5	112	82.9	32.5	59.5	172.3	247.4	25.4	161.0	150	44.5	4.1	9.6	2.0	395.4
Class III	164.3	87.9	1.0	120	115.7	77.5	32.5	59.5	198.8	298.9	25.4	212.0	200	70.0	6.1	19.7	3.0	451.6

Note: Dimensions are nominal and represent the average of assembled units. These are not the specifications of individual parts nor do they reflect manufacturing tolerances.

INSTALLATION

Determine Mounting Dimensions

Vertical Mounting Dimension – VMD

The distance from the centerline of the guide bar mounting holes to the anvil roll or ring O.D. and perpendicular to the web path

Horizontal Mounting Dimension – HMD

The distance from the support beam face (guide bar mounting surface) to the vertical centerline through the center of the anvil ring.

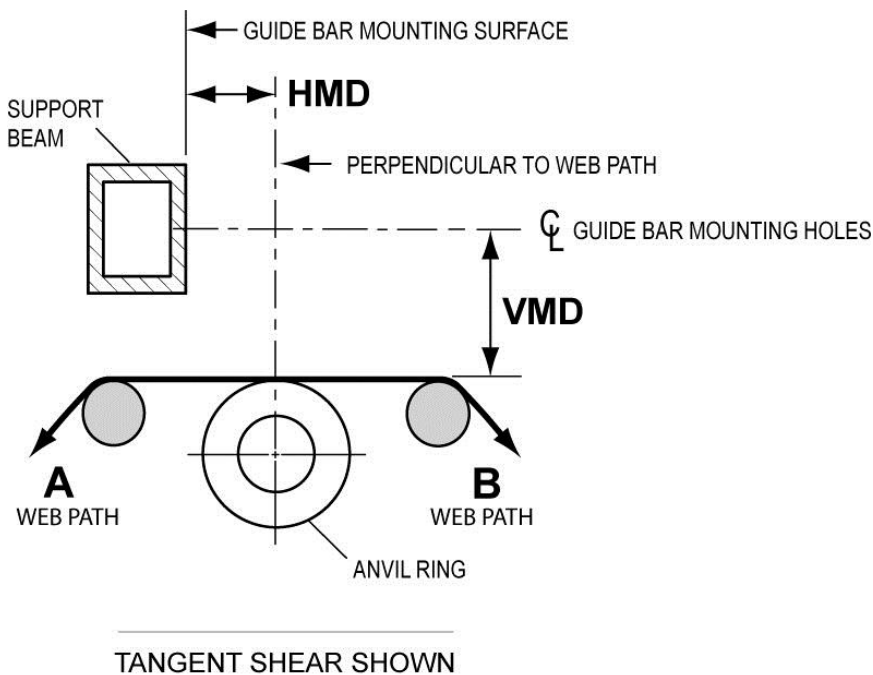

VMD (Vertical Mounting Dimension)

Tangent & Wrap Slitting	
Class I	6-29/32" (175.4 mm)
Class II	10-3/16" (258.8 mm)
Class III	12-1/4" (311.2 mm)

These dimensions reserve approximately 1/2 of blade cartridge stroke for blade regrinding.

HMD (Horizontal Mounting Dimension)

	Tangent Slitting *		Wrap Slitting **
	'A' Web Path	'B' Web Path	'A' or 'B' Web Path
Class I	2-9/16" (65.1 mm)	2-5/16" (58.7 mm)	2-7/16" (61.9 mm)
Class II	3-7/32" (81.8 mm)	2-23/32" (69.1 mm)	2-31/32" (75.4 mm)
Class III	3-27/32" (97.6 mm)	3-3/32" (78.6 mm)	3-15/32" (88.1 mm)

* These dimensions will result in setbacks as listed in *Recommended Setback Distance* on page 11.

** These dimensions provide no setback.

INSTALLATION

Install Guide Bar on Support Beam (standard guide bar shown)

- The guide bar must be straight within 0.010" (0.25 mm) on a rigid and vibration-free support.
- Avoid scratches or dents to the guide bar during installation.

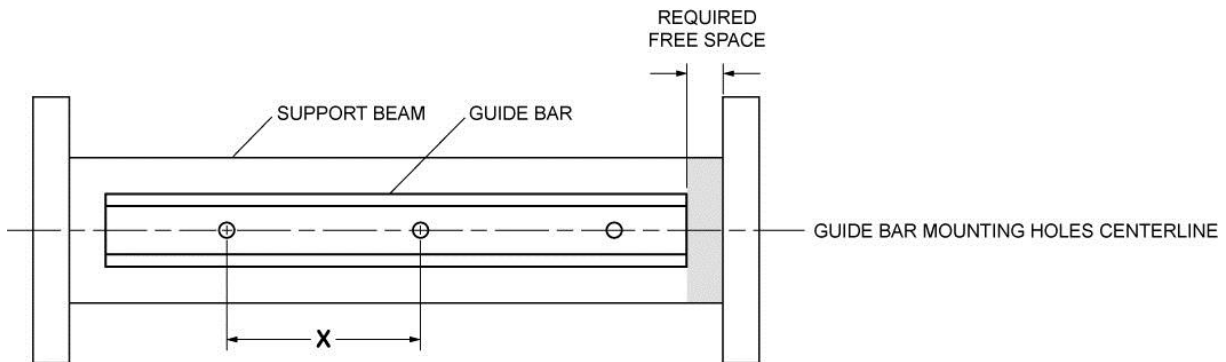

1. Determine the center-to-center distance between the mounting bolt holes (**X**) on the guide bar.
 - Standard pre-drilled dimension (**X**) is 12" (304.80 mm).
 - Drill and tap support beam for pre-drilled guide bar: 3/8"-16NC holes
 - **DuraGlide mounting option:** Use only low-head socket head bolts to mount guide bar.
2. Before transferring dimension (**X**) onto the support beam, make sure there will be enough free space at one end of the beam for knifeholder installation and removal once the guide bar is mounted.

Minimum Space Recommended for Removal (Free Space)	
Class I	2" (50.8 mm)
Class II	3" (76.2 mm)
Class III	4" (101.6 mm)

Methods for Measuring Blade Overlap (For Reference Only)

See pages 24-26 for knifeholder setup instructions.

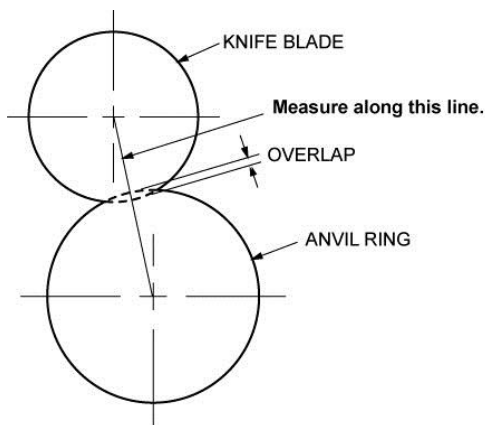

Method 1

Measure blade overlap directly along the common centerline of the knife blade and anvil ring.

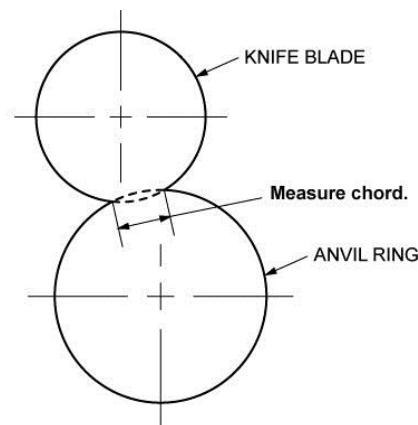

Method 2

Measure the chord of the intersection between the knife blade and anvil ring.

INSTALLATION

Mount Knifeholder – Standard Guide Bar

Manual Lock



WARNING! Blades are sharp!

Avoid injury—Tidland recommends wearing steel protective gloves when handling blades.

Installation at End of Guide Bar (Recommended)

1. Turn the brake knob counterclockwise enough to allow the brake shoe to be manually retracted into the mount. (Push the brake shoe up into mount if extended out.)
2. Align the mount with the guide bar end.
3. Slide the knifeholder onto guide bar. If clearance is restricted, remove blade cartridge (p. 28).
4. See *Adjusting the Gib* below, if necessary.
5. Turn the brake knob clockwise to secure the knifeholder in position.
6. Turn the set up knob to the red (retract) position and connect the air supply line.



Installation at Center of Guide Bar

1. Remove blade cartridge from the control body (p. 28).
2. Remove the two socket head cap screws that secure the gib to the mount; remove the gib.
3. Turn the brake knob counterclockwise to fully retract the brake shoe into the mount. (Push the brake shoe up into mount if extended out.)
4. Place the control body onto the guide bar.
5. While holding the control body securely in place, reinstall the gib. Align the gib socket head cap screw holes with the holes in the mount assembly.
6. Install and tighten the socket head cap screws to secure the gib in place.
Torque: Class I — 2.1 ft·lbs (2.85 Nm) Class II and III — 4.3 ft·lbs (5.83 Nm)
7. Turn the brake knob clockwise to secure the knifeholder in position.
8. Reinstall the blade cartridge onto the control body (p. 28).
9. Turn the set up knob to red (retract) position and connect the air supply line.

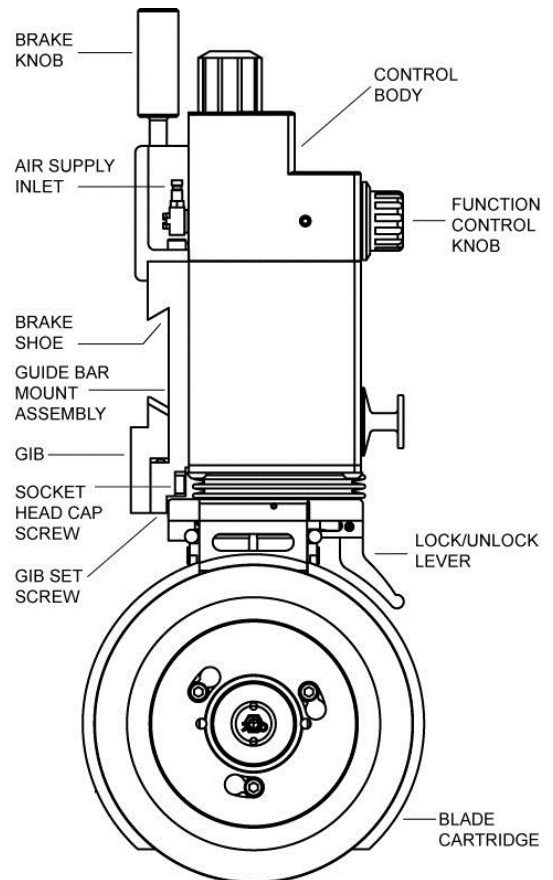

Adjusting the Gib

1. Loosen the two gib socket head cap screws by 1/4 turn.
2. Tighten or loosen the gib set screw to achieve a secure fit and smooth knifeholder traverse action on the guide bar. Recommended: 1/4 turn per adjustment.
3. Ensure that side of gib are parallel to sides of knifeholder when adjusting and tightening the two gib socket head cap screws.
Torque: Class I — 2.1 ft·lbs (2.85 Nm) Class II and III — 4.3 ft·lbs (5.83 Nm)
4. Re-adjust as necessary.

INSTALLATION

Mount Knifeholder – Standard Guide Bar

Pneumatic Lock



WARNING! Blades are sharp!

Avoid injury—Tidland recommends wearing steel protective gloves when handling blades.

Installation at End of Guide Bar (Recommended)

1. Align the mount and traverse gear with the guide bar end and gear rack.
2. Make sure the traverse/brake knob is in the unlocked (up) position. (Push the brake shoe up into the mount if extended out.)
3. Slide the knifeholder onto the guide bar. If clearance is restricted, remove the blade cartridge (p. 28).
4. Turn the traverse knob to move the knifeholder in position. See *Adjusting the Gib* below, if necessary.
5. Turn the set up knob to the red (retract) position and connect the air supply line.
6. Push down the traverse/brake knob to lock the knifeholder to the guide bar. Pull up the traverse/brake knob to unlock and traverse the knifeholder.



Installation at Center of Guide Bar

1. Remove the blade cartridge from the control body (p. 28).
2. Remove the two socket head cap screws that secure the gib to the mount; remove the gib.
3. Place the control body onto the guide bar.
4. While holding the control body securely in place, reinstall the gib and align the gib socket head cap screw holes with the holes in the mount.
5. Install and tighten the socket head cap screws to secure the gib in place.
Torque: Class I — 2.1 ft·lbs (2.85 Nm) Class II and III — 4.3 ft·lbs (5.83 Nm)
6. Turn the traverse knob to move the knifeholder into position.
7. Reinstall the blade cartridge onto the control body (p. 28).
8. Turn the set up knob to red (retract) position and connect the air supply line.
9. Push down the traverse/brake knob to lock the knifeholder to the guide bar.



Adjusting the Gib

1. Loosen the two gib socket head cap screws by 1/4 turn.
2. Tighten or loosen the gib set screw to achieve a secure fit and smooth knifeholder traverse action on the guide bar. **Recommended:** 1/4 turn per adjustment.
3. Ensure that the sides of gib are parallel to sides of knifeholder when adjusting and tightening the two gib socket head cap screws.
Torque: Class I — 2.1 ft·lbs (2.85 Nm) Class II and III — 4.3 ft·lbs (5.83 Nm)
4. Re-adjust as necessary.

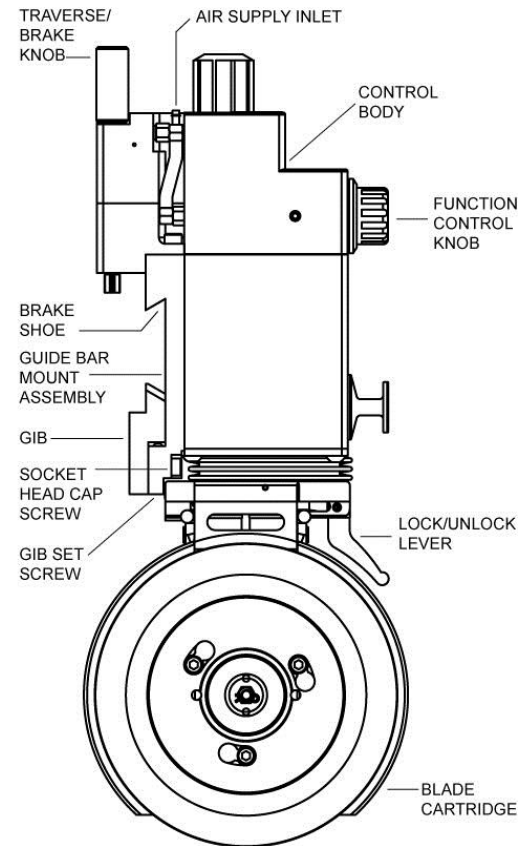

INSTALLATION

Mount Knifeholder – DuraGlide Guide Bar



WARNING! Blades are sharp!

Avoid injury—Tidland recommends wearing steel protective gloves when handling blades.

Installation at End of Guide Bar

It is not possible to install the knifeholders at the center of the guide bar; you must install them at either end.

Pneumatic Lock

1. Make sure that the bearings on the knifeholder mount are tight.
2. Align the knifeholder at the end of the guide bar and slide the knifeholder onto the guide bar. If clearance is restricted, remove the blade cartridge.
3. Turn the set up knob to the red (retract) position and connect the air supply line.
4. Push down the brake knob to lock the knifeholder to the guide bar. Pull up the brake knob to unlock and move the knifeholder along the guide bar.

Manual Lock

1. Turn the brake knob counterclockwise enough to allow the brake shoe to be manually retracted (Push the brake shoe up into mount if extended out.)
2. Align the knifeholder at the end of the guide bar and slide the knifeholder onto the guide bar. If clearance is restricted, remove the blade cartridge.
3. Turn the brake knob clockwise to secure the knifeholder in position.
4. Turn the set up knob to the red (retract) position and connect the air supply line.

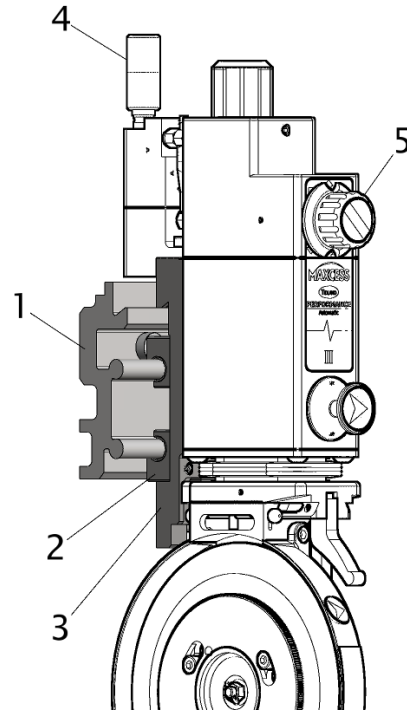

1	DuraGlide guide bar
2	DuraGlide bearings
3	Backplate
4	Lock knob
5	Function control knob

If bearings bind on the guide bar

Knifeholder movement should be smooth along the length of the guide bar. If the bearings drag or catch, check the guide bar for debris and wipe it clean. Use a light coating of dry lubricant spray; let dry and wipe off.

Serious binding indicates that the guide bar may be damaged or may not have been installed per the specifications on page 14.

INSTALLATION

Easy Glider Mount (Linear Bearing)



READ FIRST

- Do not remove the factory-installed short rail section from the linear rail.
- This rail section must be used to install the knifeholder onto the guide bar rail.
- Failure to use this rail section when installing the knifeholder may result in bearing damage and **void bearing warranty**.

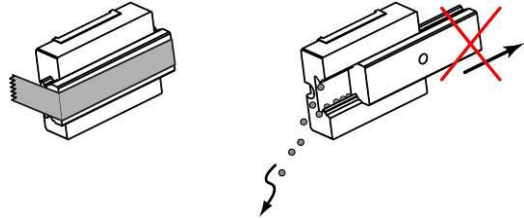

Safety Recommendation

Remove blade cartridge from knifeholder before handling.

Installing the Knifeholder on the Linear Bearing Rail

1. Choose at which end of the guide bar the knifeholders will be mounted.
2. At the mounting end only, locate and remove the #10-32 end stop screw on the face of the guide bar.
3. Do not remove the short rail from the knifeholder bearing.
4. Turn the brake knob counterclockwise to unlock.
5. Push the brake shoe up into the back plate if protruding.
6. Install the knifeholder:
 7. Hold the knifeholder and short rail section together. Carefully place the rail section into the keyway on the guide bar.
 8. Align the short rail section with the fixed bearing rail on the guide bar.
 9. Slide the knifeholder onto fixed bearing rail.
 10. Remove short section of bearing rail from the guide bar. **Note:** Keep the short rail for future maintenance and knifeholder removal.
11. Repeat Steps 4-9 until all knifeholders are installed on the guide bar.
12. After all knifeholders are installed, reinstall the #10-32 screws in the end stop.
13. Reinstall blade cartridges on knifeholders.
14. Turn the function control knob to red (retract) position on all knifeholders.

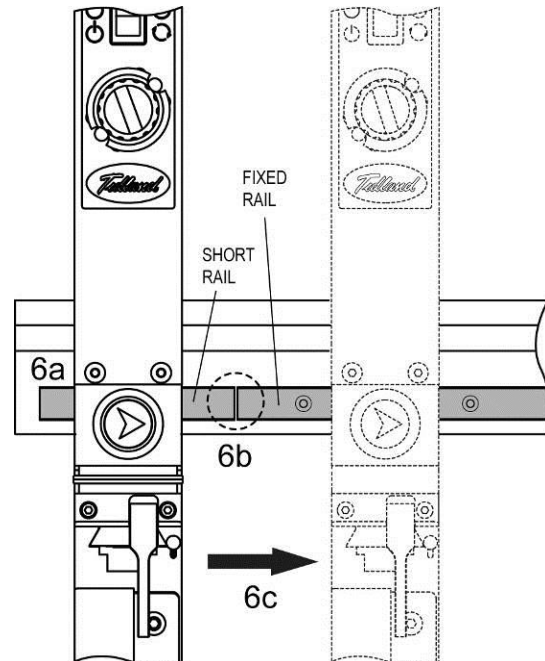

INSTALLATION

Removing the Knifeholder with *Easy Glider Mount (Linear Bearing)*



Safety Recommendation

Remove blade cartridge from knifeholder before handling.

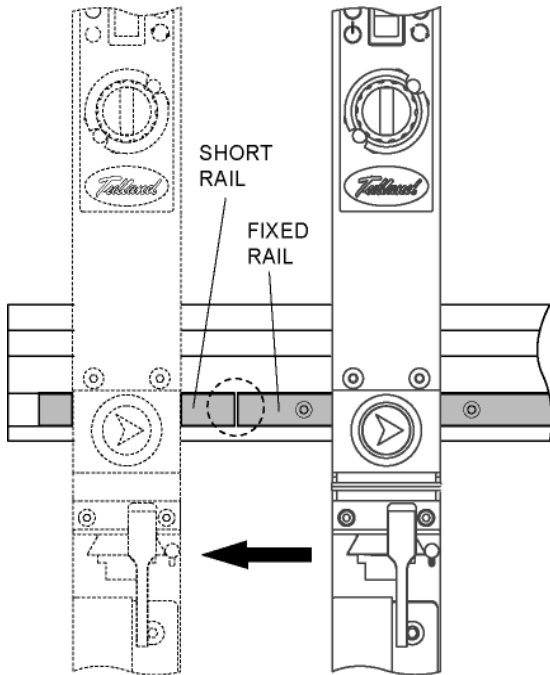

1. Remove the blade cartridge.
2. Choose at which end of the guide bar the knifeholder will be removed; move the knifeholder just to the end of the fixed rail on the guide bar.
3. Locate and remove the #10-32 screw from the end stop on the face of the guide bar.
4. In the space at the end of the guide bar, align the short piece of rail (received with each knifeholder bearing mount) with the fixed rail and transfer the knifeholder from the fixed rail to the short rail.
5. Hold the knifeholder and the short rail together and carefully remove them from the guide bar. Do not remove the short rail from the knifeholder bearing mount. You will need it to reinstall the knifeholder on the guide bar.

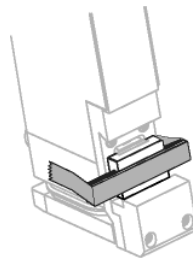

★TIP

Secure the short rail to the linear bearing with a small piece of tape to retain the bearing balls during maintenance.

INSTALLATION

Install Pneumatic System

Tidland recommends the use of a filtered and regulated pneumatic system to prevent airborne oil or water from contaminating the knifeholders and to provide the correct air pressure to the knifeholders to help achieve quality slitting.

The pneumatic system* includes:

- A) 3/8" (9.52mm) supply air lines
- B) 5 micron air filter/pressure regulator with gauge (0-100 psi or 0-6.9 bar)
- C) Coalescing filter
- D) 3-way manual valve with muffler
- E) Quick exhaust valve with muffler

(Quick disconnect fittings and air manifolds are also available from Tidland.)

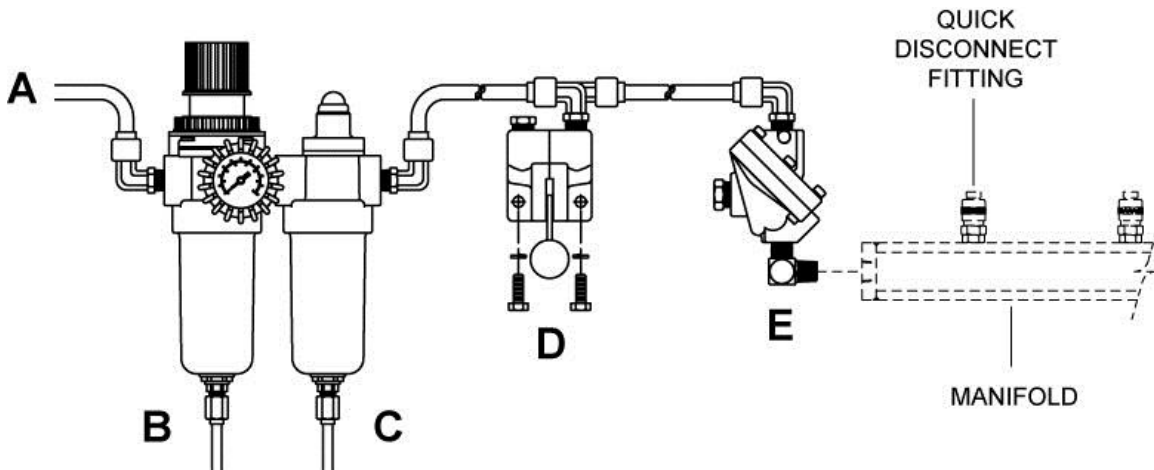

- Recommended operating air pressure: 60-75 psi (4.1-5.2 bar).
Note: This is a guideline for knifeholder setup – the actual air pressure is dependent upon application and material.
- Maximum operating air pressure: 100 psi
Note: Internal hoses may rupture if maximum air pressure is exceeded.
- Clean, non-lubricated, dry air is required for optimal performance of the knifeholder.
- Before operating, make sure that the air lines from the air manifold to the knifeholder are securely connected.
- Single manifold system – Tidland PN 520984
Dual manifold system – Tidland PN 520985

KNIFEHOLDER SIDE FORCE / DOWN FORCE OUTPUT CHART

Knifeholder loads will vary slightly from averages shown.

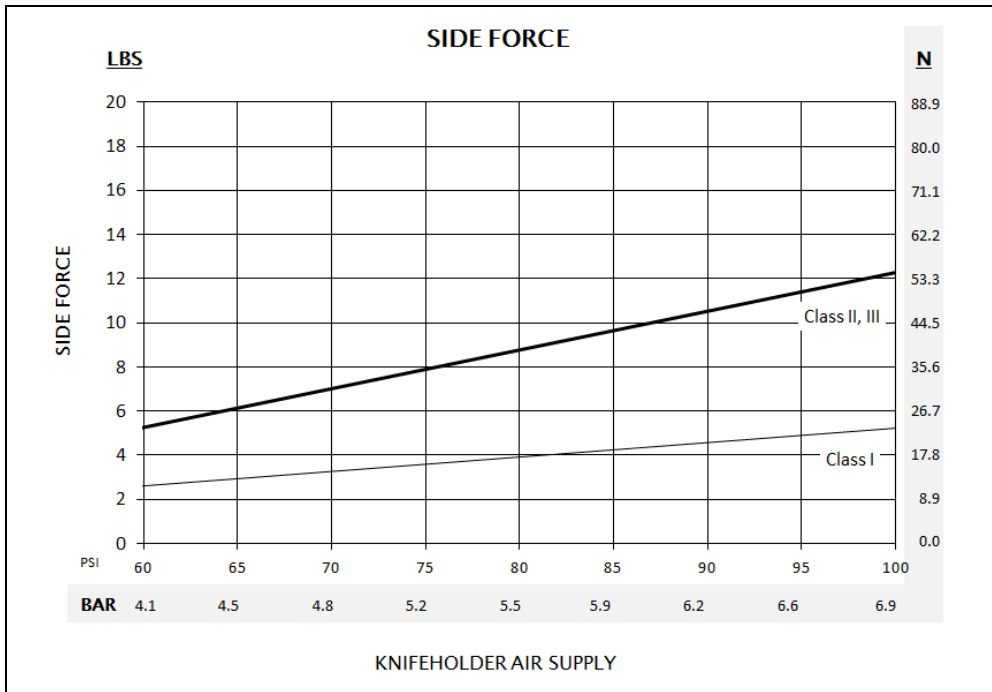
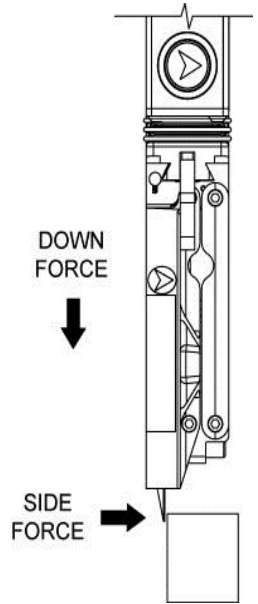
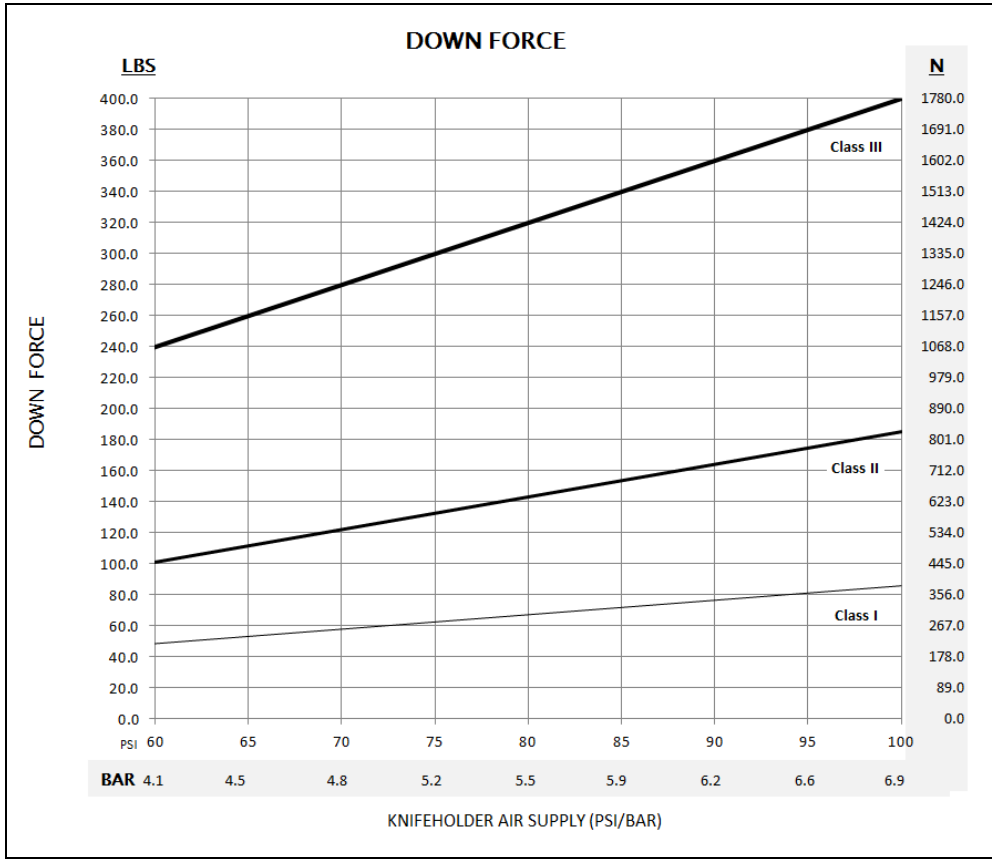

CANT KEY

Selection

Cant Angle Options: 0°, 1/4°, 1/2°, 1°
The angle is engraved in the key.

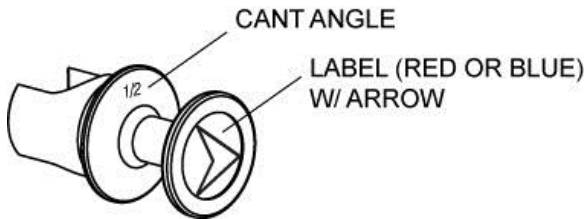

The cant key label color indicates the web path direction as determined at the time of sale.

'A' Web Path = RED label
'B' Web Path = BLUE label

If the web path needs to be reversed at any time, Tidland recommends replacing the cant key label with one of the correct color.

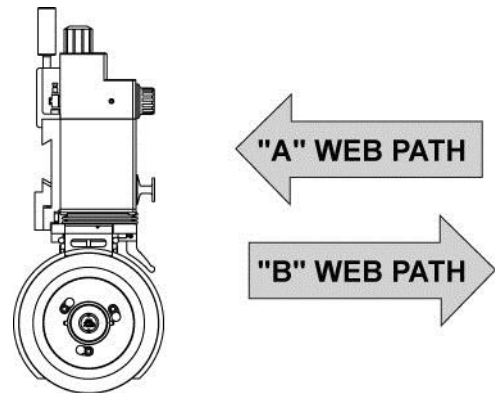

Cant Key Orientation

The arrow on the cant key label should:

- point to the nip point (blade contact side) of the anvil ring (see page 23).
- point in the same direction as the arrow on the blade cartridge.

Arrows pointing in opposite directions indicate that:

- the nip point will not be closed, resulting in poor slit quality, and either
- the cant key orientation needs to be reversed, or
- the cartridge orientation (left or right hand) must be changed.

To change the cant key orientation, pull the key all the way out of the control body, rotate it 180° and reinstall the key, pushing it firmly into the control body.

Cant Key Maintenance (p.28)

CANT KEY

Cant Key Orientation (continued)

"A" Web Path

- Web moves from control side of knifeholder toward the guide bar mount.
- Cant key label is RED.
- Cant key arrow points toward the THIN side of the cant key.
- Blade cartridge arrow points to the nip point (contact side of anvil ring.)

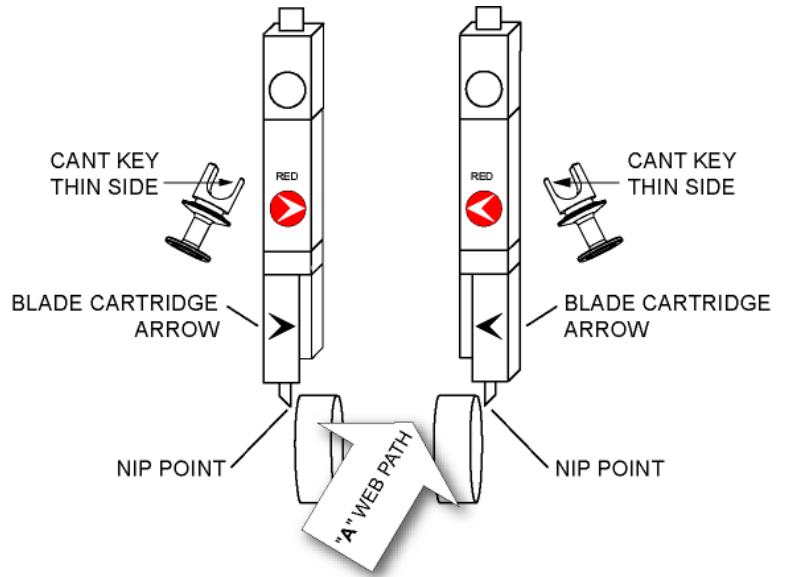

"B" Web Path

- Web moves from the guide bar mount toward the control side of knifeholder.
- Cant key label is BLUE.
- Cant key arrow points toward the THICK side of the cant key.
- Blade cartridge arrow points to the nip point (contact side of anvil ring.)

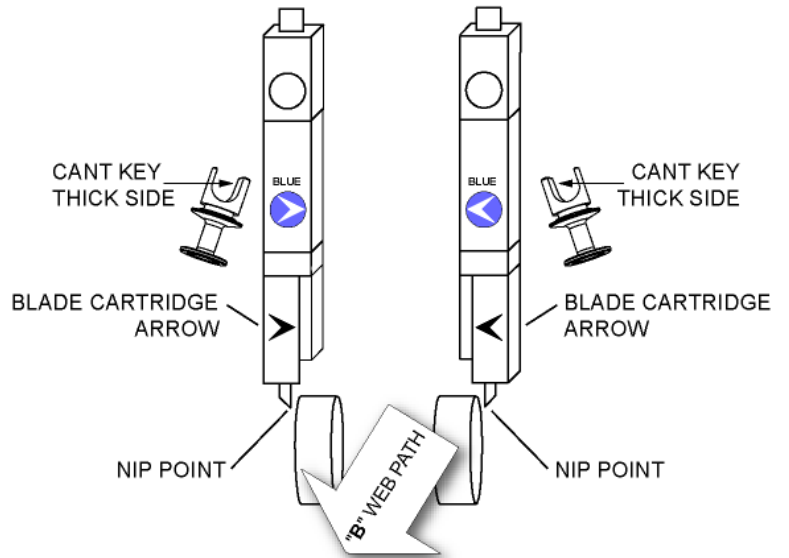

360° Blade Guard Cartridge

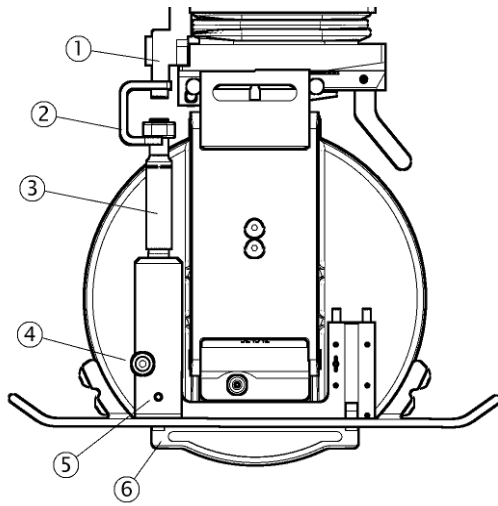

1	Guide bar mount
2	Bracket (stationary)
3	Actuator assembly (reversible)
4	Actuator assembly release pin
5	Adjustment screw
6	Blade guard

Reversing the blade guard actuator assembly



Remove the blade cartridge from the knifeholder before reversing the actuator assembly.

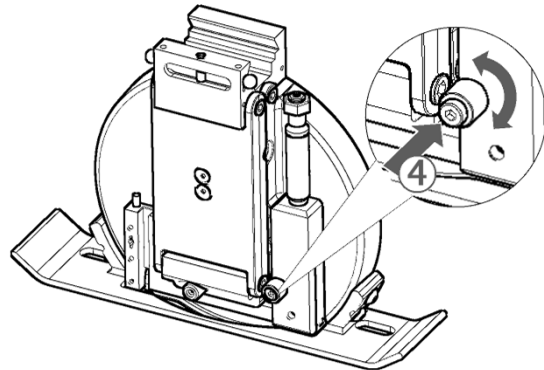
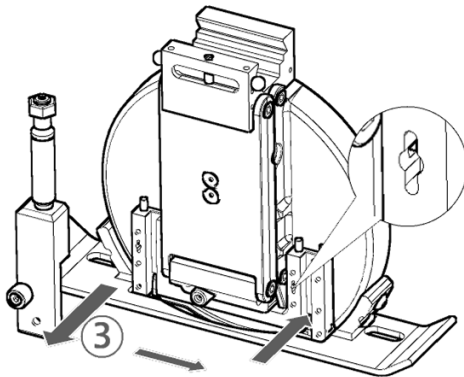
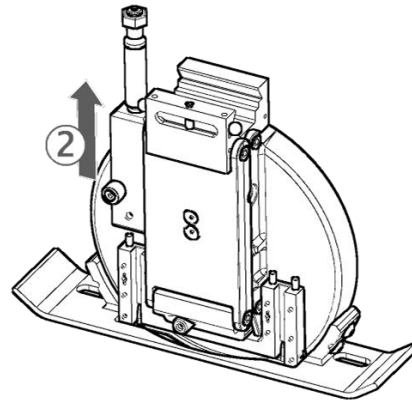
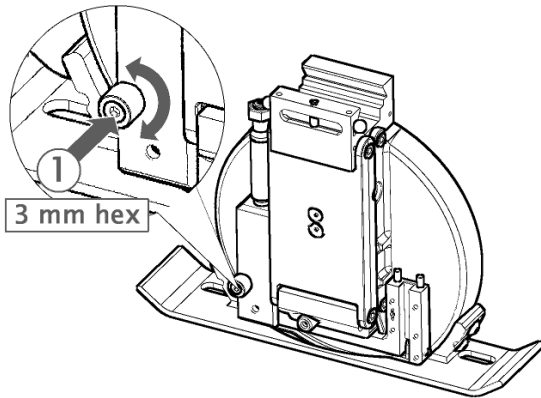

Knifeholder Setup

Manual Lock

Ensure that

- anvil rings are in a pre-selected slit position.
- blade cartridge is securely locked to control body.
- air supply is attached.

1. Turn the function control knob to the red (retract) position.
2. Loosen the brake knob. Knifeholder is ready to move.
3. **For first time operation or for use with a new full diameter blade, adjust the depth control knob to one-half its total stroke.**
4. Manually slide the knifeholder along the guide bar to place knife blade within 1/4" of the anvil ring at the new slit position.
Caution! Ensure that knife blade is not directly over the anvil ring in order to prevent damage by collision when blade cartridge is extended in Step 5.
5. Turn the function control knob to the yellow (setup) position to extend the knifeholder blade cartridge.
6. Manually slide the knifeholder along the guide bar until the knife blade and the anvil ring just touch.
7. Tighten the brake knob to lock the knifeholder to the guide bar (knife blade and anvil ring should be touching).
8. Observe overlap of knife blade and anvil ring. See Measuring Blade Overlap (p. 14).
9. If the overlap is correct —0.030" (0.8mm)— the knifeholder is ready to slit: go to Step 13. If the overlap is incorrect, go to Step 10 to make adjustments. (Some web products may require more or less overlap.)
10. Turn the function control knob to the red (retract) position. **Note:** All depth control adjustments must be made in the red (retract) position.
11. To increase the overlap, turn the depth control knob counterclockwise.
To decrease the overlap, turn the knob clockwise.
Note: One click increases or decreases the overlap .004" (0.1 mm).
One complete turn increases or decreases the overlap .040" (1.0 mm).

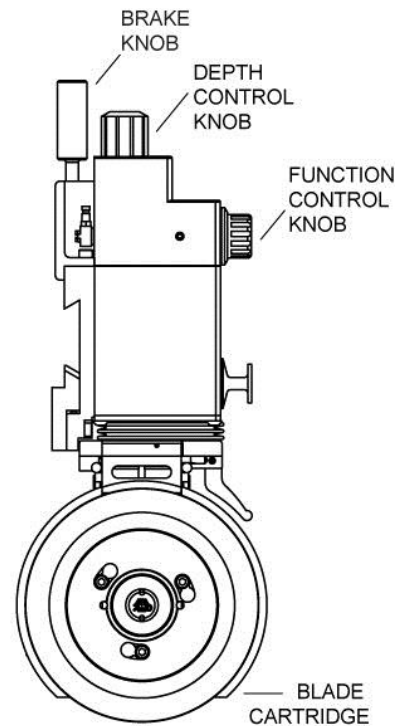

DO NOT SCREW the depth control knob all the way into the body. There will be no travel during cartridge extension.

12. When overlap is correct, turn function control knob to the red (retract) position, if necessary, to retract the blade cartridge, then turn it to the green (run) position, extending the blade cartridge.
Caution! If the blade cartridge is not retracted before turning to the green (run) position, it will not function as designed and may result in poor slit quality.
13. The knifeholder is ready to slit.



Keep knifeholders and blade cartridges free of dust and debris during operation. Maintenance schedule is dependent upon machine environment.

Knifeholder Setup

Pneumatic Lock

Ensure that

- anvil rings are in a pre-selected slit position.
- blade cartridge is securely locked to control body.
- air supply is attached.

Note: The Duraglide and *Easy Glider* mounts do not use the gear rack traverse function. Use the knob only to release or lock the brake, and then slide the knifeholder manually along the guide bar.

1. Turn the function control knob to the red (retract) position.
2. Lift the traverse/brake knob. Knifeholder is ready to move.
3. **For first time operation or for use with a new full diameter blade, adjust the depth control knob to one-half its total stroke.**

4. Manually slide the knifeholder along the guide bar to place knife blade within 1/4" of the anvil ring at the new slit position.

Caution! Ensure that knife blade is not directly over the anvil ring in order to prevent damage by collision when blade cartridge is extended in Step 5.

5. Turn the function control knob to the yellow (setup) position to extend the blade cartridge.
6. Turn the traverse/brake knob to move the knifeholder along the guide bar until the knife blade and the anvil ring just touch.
7. Press down on the traverse/brake knob to lock the knifeholder to the guide bar. Knife blade and anvil ring should be touching.
8. Observe overlap of knife blade and anvil ring. See *Setting Blade Overlap* (p. 14).
9. If the overlap is correct —0.030" (0.8mm)— the knifeholder is ready to slit: go to Step 13. If the overlap is incorrect, go to Step 10 to make adjustments. (Some web products may require more or less overlap.)
10. Turn the function control knob to the red (retract) position. Note: All depth control adjustments must be made in the red (retract) position.
11. To increase the overlap, turn the depth control knob counterclockwise.
12. To decrease the overlap, turn the knob clockwise.

Note: One click increases or decreases the overlap .004" (0.1 mm).

One complete turn increases or decreases the overlap .040" (1.0 mm).

DO NOT SCREW the depth control knob all the way into the body. There will be no travel during cartridge extension.



Caution! If the blade cartridge is not retracted before turning to the green (run) position, it will not function as designed and may result in poor slit quality.

13. The knifeholder is ready to slit.

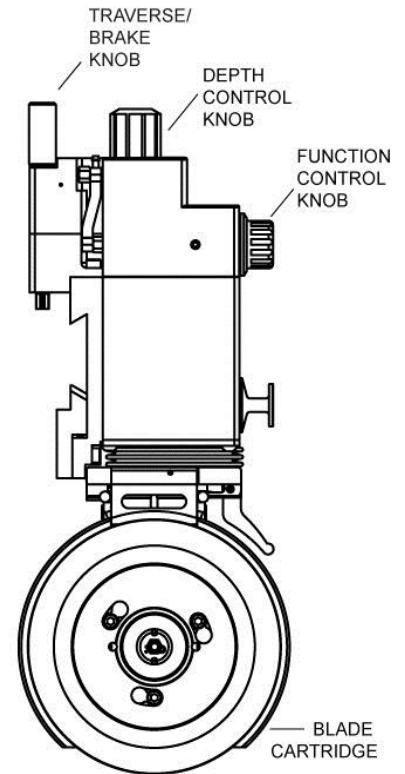

Keep knifeholders and blade cartridges free of dust and debris during operation. Maintenance schedule is dependent upon machine environment.

Preventive

- Keep anvil rings and knifeholder blades clean and balanced.
- Do not use oil lubricants in knifeholder. Oil lubricants may cause the knifeholder to function improperly. Use only those lubricants recommended in this publication.

Daily

- Keep all knifeholders clean of debris.
- Check air pressure to the knifeholders: Clean, dry, non-lubricated air is essential for optimal knifeholder performance.
- Check for air leaks at the knifeholder and manifold.

Note: DO NOT IMMERSE knifeholders in solvents. Wipe the outer surfaces with a clean, dry rag.



Blades are sharp! Can cause serious injury.

Repairs should be performed by trained repair personnel only.

Weekly

- Check knifeholder air pressure. Knifeholder air pressure requirements: 1½ cfm @ 60-90 psi (4.1-6.2 bar).
- Blow down the blade cartridge to remove dust build up.
- Check hose connections to the knifeholders for leaks or cracks.
- Inspect control body dovetail assembly o-rings. Replace if damaged or missing.
- Check blade cartridge half stroke function.

Monthly

- Check adjustment of gib to the guide bar for minimal clearance between knifeholder mount and guide bar.
- Clean all surfaces of the control body and blade cartridge.
- Inspect bellows for tears around dovetail mount. Replace if necessary.

Bi-Yearly

- Clean and inspect blade cartridge bearings for looseness.
- Remove depth control knob and inspect for dust build up, if applicable.
- Remove cant key and inspect for excessive wear. Replace if necessary.
- Check cant key o-ring for damage. Replace if necessary.

Guide Bar Cleanup

- Periodically wipe the guide bar clean and lubricate with a silicone dry film lubricant. Tidland Corporation recommends using *Dow Corning 557 Silicone Dry Film Lubrication* to assure smoother knifeholder movement. Spray the guide bar, let dry, and then wipe the guide bar again.

Cant Key O-ring

The cant key must remain tight in the knifeholder body.

If the cant key becomes loose in the body or if cracks in the o-ring are visible, replace the o-ring.

Replacing the O-ring

1. Pull the o-ring straight out from the control body.
2. Remove o-ring from the cant key.
Caution! Do not nick or otherwise damage o-ring groove edges when removing o-ring.
3. Using Parker Super O-Lube, lubricate the new o-ring and the cant key o-ring groove.
4. Install new o-ring into the cant key o-ring groove.
5. Select arrow orientation as described in *Cant Key Orientation* on page 22.
6. Push the cant key straight into the knifeholder body.

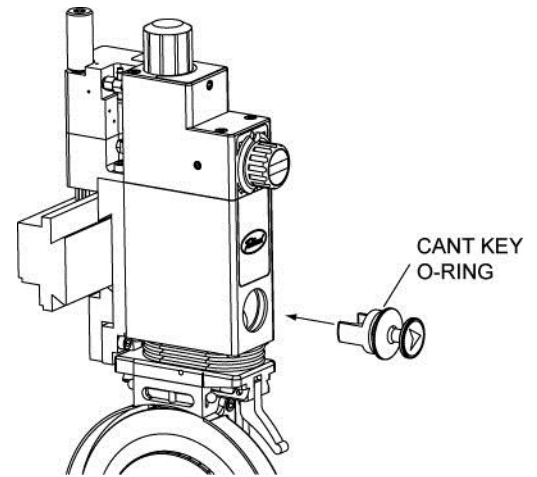

Blade Cartridge

Removing the Cartridge

1. Turn the function control knob to the red (retract) position.
2. Pull the lock/unlock lever up to unlock the blade cartridge.
3. Press and hold down the safety lock pin and slide the blade cartridge off the control body.

Reinstalling the Cartridge

1. Slide the blade cartridge onto the control body.
2. The safety lock pin will 'snap' in place when the blade cartridge is in the correct position.
3. Pull the lock/unlock lever down to lock the blade cartridge to the control body.
4. Confirm that the arrow on the blade cartridge is pointing in the same direction as the arrow on the cant key.

Reversing the Cartridge

1. Follow Steps 1 through 3 above to remove the blade cartridge.
2. Install the blade cartridge onto the control body in the opposite direction from the way it was removed. The safety lock pin will 'snap' in place when the blade cartridge is in the correct position.
3. Pull the lock/unlock lever down to lock the blade cartridge to the control body.
4. Remove the cant key and replace it back in the control body, making sure that the arrow on the cant key is pointing in the same direction as the arrow on the blade cartridge.

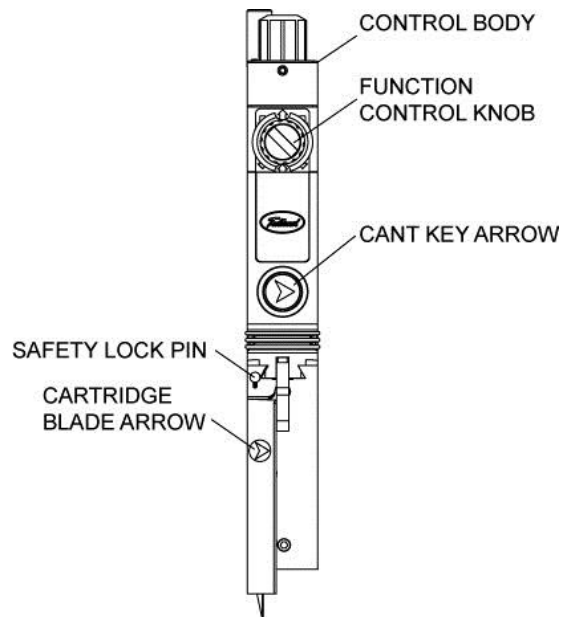

Knife Blade



Blades are sharp! Can cause serious injury.
Repairs should be performed by trained repair personnel only.

For ease and safety during blade maintenance, Tidland recommends the use of the Tidland Bench Fixture.

Removing

1. Remove the blade cartridge (p. 28)
2. Press and hold the blade lock pin and rotate the blade hub until it stops.
3. Loosen the three blade clamp screws.
4. Rotate the blade clamp counterclockwise and slide it off the blade hub when the clearance holes are aligned with the blade clamp screw heads.
5. Remove the knife blade.

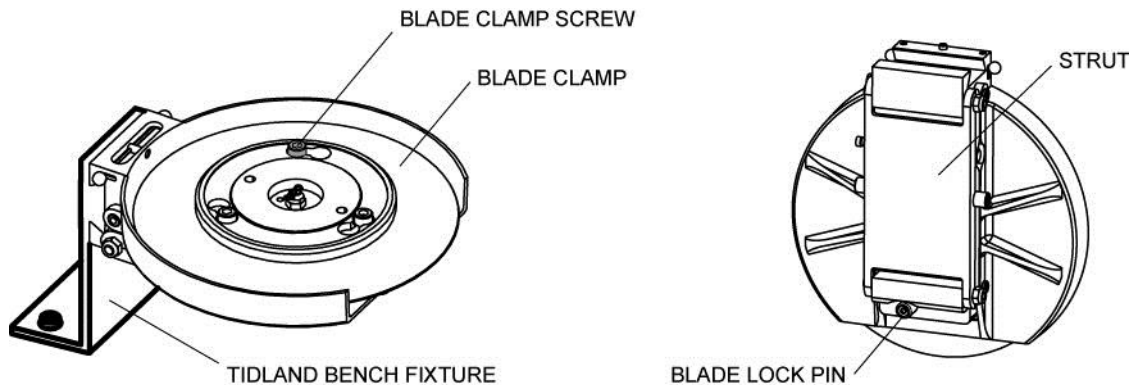

Reinstalling

1. Make sure the blade cartridge is held securely.
2. Clean the blade hub surface where the blade mounts to assure correct fit of the blade and to help prevent blade runout (wobble).
3. Replace the knife blade with the slitting edge toward the strut.
4. Replace the blade clamp onto the blade hub. Rotate the blade clamp clockwise until the counter-bored areas of the clearance holes are under the blade clamp screw heads.
5. Tighten the three Grade 8.8 blade clamp screws to the appropriate torque value:
 - Class I 9 in·lbs (1.02 Nm)
 - Class II and III 45 in·lbs (5.10 Nm)
6. Replace the blade cartridge onto the dovetail (p. 28).

Dovetail – Class I, II and III

Replacing the O-ring(s)

Visually inspect the dovetail and replace any damaged or missing o-rings.

1. Remove the blade cartridge from the control body (p. 28).
The dovetail o-rings **(1)** are located on the underside of the control body dovetail.
2. Using a sharp object, such as a scratch or piercing awl, remove the damaged o-ring(s).
3. Completely clean out the o-ring pocket with rubbing alcohol.
4. Make sure the o-ring pocket is dry.
5. Use a toothpick to apply a small amount of *LOCTITE® 480* to the pocket only.
Note: Do not let *LOCTITE* enter the air supply hole.
6. Push the new o-ring into the o-ring pocket by hand.
Note: Make sure the o-ring is seated flat in the pocket.
7. Let the o-ring set for a minimum of one hour.
8. Apply a light film of *Parker Super O-Lube* over each o-ring.
9. Confirm that each o-ring hole is not plugged with *LOCTITE*.
10. Replace the blade cartridge (p. 28).

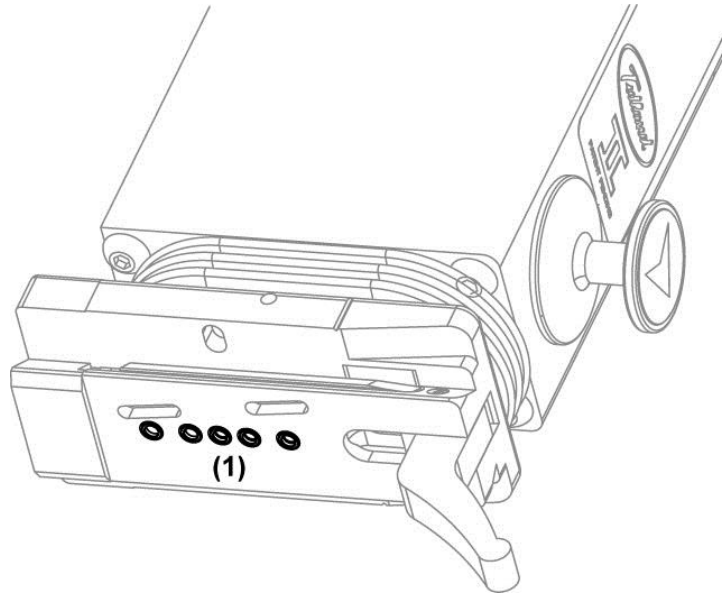

360° Blade Guard – Class I

Inspecting and Replacing Parts

Removing the Guard

1. Disconnect the air supply to the knifeholder.
2. Remove the knife blade from the cartridge.
3. Remove two flat head screws (1) from the blade cartridge body.
4. Slide the cylinder mount assembly (2) away from the cartridge body to detach the guard (3) and spring (4) from the pivot points (5).

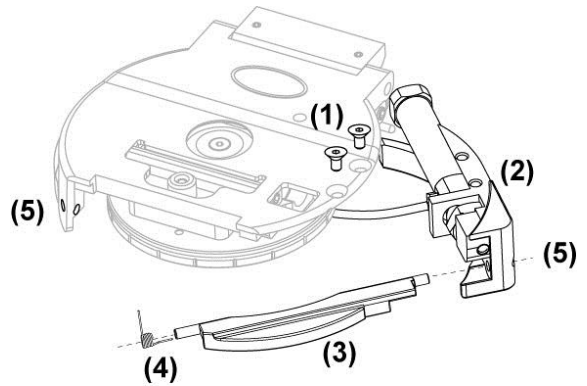

Inspecting the Parts

- Inspect spring; replace if broken.
- Clean blade cartridge thoroughly. Inspect pivot points for debris buildup. To reduce dust buildup and contamination, do not lubricate the pivot points.
- Inspect the guard and cylinder mount assembly for damage. Bent components may not function correctly.

Reinstalling the Guard and Spring onto the Cartridge Body

1. Orient the spring on the guard as shown.
2. Insert guard pivot pin into the pivot hole in the cylinder mount block (6).
3. Insert the pivot pin at the other end of the guard into the mating pivot hole (7).
4. Spring must be oriented as shown:
 - a. The bent end (8) is on the inside of the guard when in guarded position.
 - b. The long straight end (9) must bend up inside the interior wall of the cartridge in order to provide spring tension.
5. Connect the air supply and test guard operation before putting unit back into production.
6. Reinstall the knife blade in the cartridge.

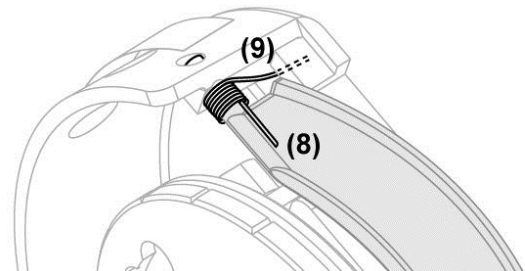
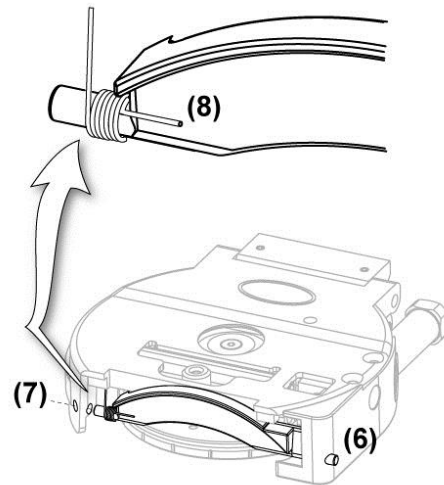

TROUBLESHOOTING

Slit Quality

Problem	Possible Cause	Recommended Solution	Page
The slit edge is fuzzy	Dull blade	Replace blade.	29
	Wrong cant key	Replace cant key.	22
	Knifemaker is loose on the guide bar	Check the knifemaker to make sure that it is secure on the guide bar mount and check gib adjustment.	15-16
	Too much overlap	Correct overlap, see <i>Knifemaker Operation</i> .	24-26
	Incorrect setback	Check geometry.	11
Slit line is not straight	Driven anvil run-out	Reset anvil ring.	
	Knifemaker is loose on the guide bar	Check the knifemaker to make sure that it is secure on the guide bar mount and check gib adjustment.	15-16
Web tears or splits	Incorrect setback	Check geometry.	11
	Too much overlap	Correct overlap; see knifemaker installation.	24-26
	Insufficient overspeed of the driven anvil	Adjust overspeed to be 3-5% greater than the winder speed.	
Web folds down	Wrong cant key	Replace cant key.	22
	Cant key is incorrectly installed	Check web direction, see <i>Cant Key Installation</i> .	22
	Dull blade	Replace blade.	29
	Incorrect setup	See <i>Knifemaker Operation</i> .	24-26
Web breaks	Web tension is too high	Reduce tension.	
	Low driven anvil speed	Check the driven anvil speed.	
Short blade life	Too much overlap	Correct overlap, see <i>Knifemaker Operation</i> .	24-26
	Side force too high	Check air pressure.	
	Driven anvil run-out	Reset anvil ring.	
Web bunches in front of knife blade	Insufficient overspeed of the driven anvil	Adjust overspeed to be 3-5% greater than the winder speed.	

TROUBLESHOOTING

Knifeholder Performance

Note: If you experience any problems when starting up the knifeholder system, contact Tidland Customer Service immediately. 1-800-426-1000

Problem	Possible Cause	Recommended Solution	CLI	II & III
Sluggish knifeholder action (extension or retraction)	Low air pressure	Minimum 50 psi required	-	-
	Air fitting leaks	Check items 5, 31.	p. 52	p. 58
	Air leak around depth control knob in the extended position only.	Check for damaged o-ring (item 7). See Upper Body & Piston Disassembly.	p. 52	p. 58
	Air leak around depth control knob in the extended or retracted position	Check for damaged o-ring on 3-way valve (item 16). Contact Tidland Knifeholder Technician for more information before disassembly. 1-800-426-1000	p. 43	p. 45
	Air leak around function control knob in the extended or retracted position.	Check for damaged o-ring (item 52). See Function Control Knob Disassembly.	p. 52 p. 47	p. 58 p. 47
	Air leak at control body to blade cartridge interface	Check lock/unlock lever; must be in locked position (down).	p. 28	p. 28
	Missing or damaged dovetail o-ring.	Replace o-ring (item 28). See Dovetail Disassembly.	p. 40	p. 40
	Body gasket leak.	Check for loose screws (item 48).	p. 52	p. 58
	Lubrication required on internal body parts: Piston Assembly O-ring Piston Guide Rod Piston Assy Stroke Stop Rod Piston Guide Rod Bushing	See Upper Body & Piston Disassembly Procedures <i>and</i> Lubrication Chart	p. 43 p. 48	p. 45 p. 49
Piston Assembly sticking due to knifeholder abuse	Dropping knifeholder or striking with hammer can cause binding. Rebuild knifeholder and replace non-repairable parts.		Contact Tidland	
Knifeholder doesn't retract when Function Control Knob is in center (red arrow) position.	Broken piston return spring	Replace spring (item 33). See Dovetail Disassembly <i>and</i> Upper Body, Lower Body and Piston Disassembly.	p. 52 p. 40	p. 58 p. 40
			p. 43	p. 45
Function Control Knob feels excessively tight.	Dry o-ring	Lubricate o-ring (item 52). See Function Control Knob Disassembly <i>and</i> Lubrication Chart	p. 52 p. 47	p. 58 p. 47
			p. 48	p. 49

Continued next page

TROUBLESHOOTING

Continued

Problem	Possible Cause	Recommended Solution	CLI	II & III
Depth Control Knob feels too tight or loose.	Loose or damaged detent	Important: The detent (item 13) keeps the depth control knob from rotating during slitting operation. If the detent loosens or breaks, it must be replaced.	p. 52	p. 58
Difficult knifeholder movement on guide bar	Dirty guide bar	Clean the guide bar and lubricate with <i>Dow Corning 557 Dry Film Lube</i> .		
	Sticky brake shoe	Clean brake shoe. Clean & lubricate brake shoe o-ring. Use <i>Parker Super O-Lube</i> .	pp. 66-70	
	Duraglide guide bar not installed correctly.	Make sure guide bar is installed to specifications.	p. 14	
	Check DuraGlide bearing liners for wear or damage.	Replace worn or damaged liners.		
Cartridge 360° blade guard does not pivot	Low air pressure	Class I: Check air pressure; guard should actuate at 20 psi. Class II/III: check o-rings in the actuator assembly (items 27-37). If Class II/III guard is slow to engage, adjust the flow control setting (see page 9).		p. 62
		Check internal hoses for obstructions (items 35-37, 66-68). Check all hose connections. Listen for leaks at the air fittings. (Do not use soap spray solution to determine location of leaks.)	p. 52	p. 58
	Air leaks at the air fittings	Remove air fittings and apply <i>Loctite 242</i> to threads. Reinstall and tighten air fittings.		
	Moving parts are obstructed	Check cartridge for debris and dust buildup; blow pivot points clean with compressed air.		
	Broken spring (Class 1 only)	Replace spring (item 4).	p. 30	n/a
Blade Cartridge – no side stroke (run or setup)	Blade cartridge not fully installed	Ensure blade cartridge is pushed securely into place on knifeholder and that the lock/unlock lever is in the locked position (down).	p. 28	p. 28
	Test to determine if problem stems from control body or blade cartridge	Remove non-functional blade cartridge and replace with functional blade cartridge.	p. 28	p. 28
	If after replacing the blade cartridge the control body is functional but the blade cartridge is not. Note: Excessive buildup of dust can prevent the 3-way valve from activating the airflow required to shift the cartridge.	Check air pressure (min. 50 psi required); look for any missing dovetail o-rings (item 59). With air hose, blow out any dust accumulated in the depth control knob counter-bore. Remove, clean out and reassemble knob. Replace knob, if necessary.	p. 52	p. 58
			p. 47	p. 47

Continued next page

TROUBLESHOOTING

Continued

Problem	Possible Cause	Recommended Solution	CLI	II & III
Blade Cartridge – no sidestroke (run or setup)	Control body to blade cartridge interface	Ensure that blade cartridge safety lock pin is fully engaged with the control body and that the lock/unlock lever is in the lock position.	p. 28	p. 28
	Clogged dovetail o-ring (item 59)	Plunge hole gently with small diameter wire (e.g., paper clip).	p. 52	p. 58
	Internal hose problem (if knifeholder has been disassembled)	See hose parts illustration; (items 35-37, 66-68). Refer to knifeholder <i>Air Flow Schematic</i> .	p. 52 p. 50	p. 58 p. 51
Blade Cartridge – sidestroke before completing downstroke (knifeholder extension)	Caused by removal and incorrect replacement of control body internal hoses.	See hose parts illustration; (items 35-37, 66-68). Refer to knifeholder <i>Air Flow Schematic</i> .	p. 52 p. 50	p. 58 p. 51
Blade Cartridge – no half-stroke	Blade cartridge not fully installed	Ensure that blade cartridge safety lock pin is fully engaged with the control body and that the lock/unlock lever is in the lock position.	p. 28	p. 28
	Sticky set stop piston	Increase air pressure to 100 psi. Cycle function control knob from red to yellow several times. Decrease air pressure and verify half stroke function. Note: The full stroke should provide approximately double the movement of that seen by the half-stroke.		
	Excessive lubrication on set stop piston o-ring	Remove set stop piston and wipe excess lube from the o-ring. Class I; item 20 Class II and III; item 26	p. 55-56	p. 60

KNIFEHOLDER DISASSEMBLY AND MAINTENANCE

Class I, II and III



The disassembly instructions in this manual are for your safety and protection. They are a guide for selective sub-assembly inspection, maintenance and part replacement. Follow all instructions as written. To avoid warranty violations, consult with a Tidland Knifeholder Service Technician for any disassembly not covered in this publication.

Air Flow Schematics help ensure that hoses are oriented and reconnected properly during reassembly. Before beginning any disassembly, refer to the chart below to match your knifeholder model with the correct Air Flow Schematic. Lift the knifeholder bellows to see the hose layout for your model.

Class I	3 hoses	Before June 2003	page 50
Class I	2 hoses	After June 2003	page 50
Class I	2 ⇔ 3 hoses	After Sept 2010	page 50
Class II	3 hoses	n/a	page 51
Class III	3 hoses	n/a	page 51

Tidland Customer Service
1-800-426-1000

KNIFEHOLDER DISASSEMBLY AND MAINTENANCE

Control Body Sub-Assembly Identification

Class II shown

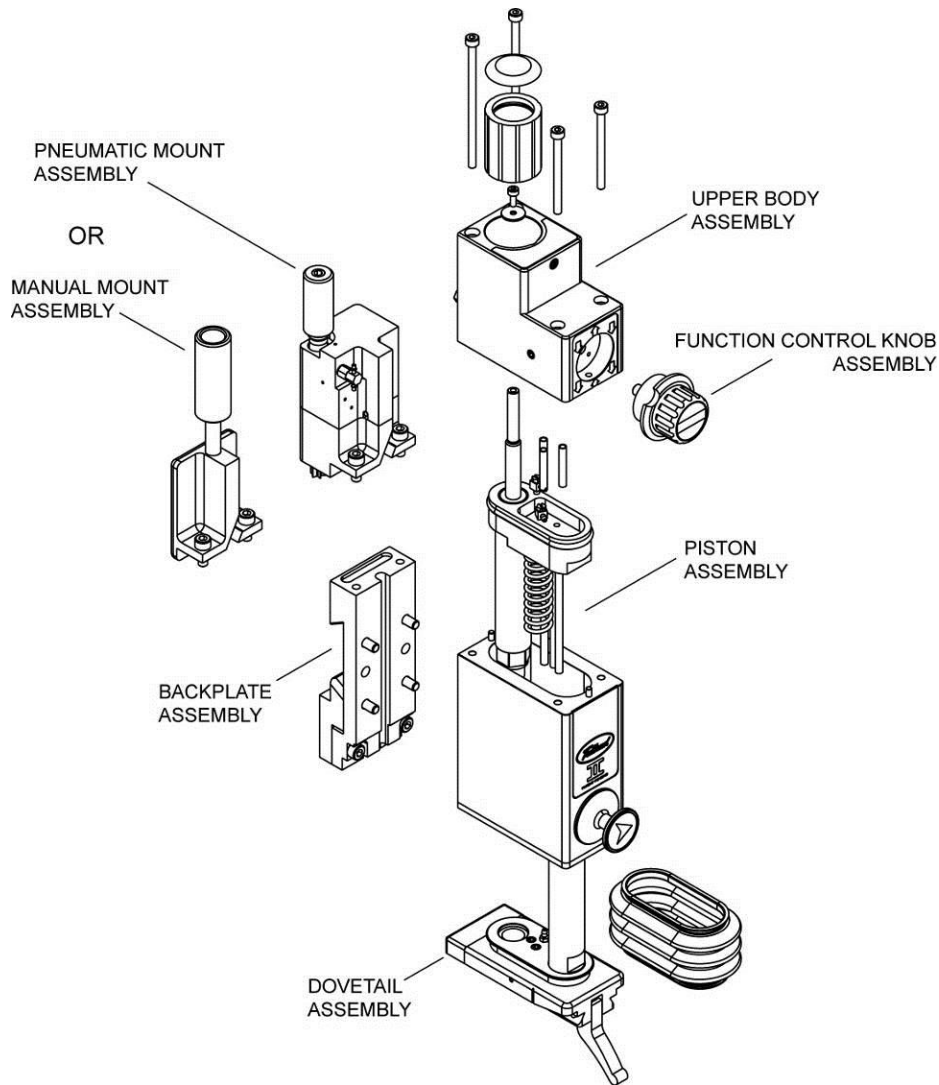

KNIFEHOLDER CONTROL BODY SUB-ASSEMBLIES*	CLASS I	CLASS II	CLASS III
Guide Bar Mount Assembly (Manual Lock)			
Manual Lock Assembly	555538	544156	544156
Back Plate Assembly	550708	550709	550710
Guide Bar Mount Assembly (Pneumatic Lock)			
Pneumatic Lock Assembly	555539	550707	550707
Back Plate Assembly	550708	550709	550710
Dovetail Assembly	524970	528797	529514
Upper Body Assembly	536437	531133	535900
Piston Assembly	536439	530353	535902
Setup Knob Assembly	536436	530354	530354
Lower Body Assembly	536438	531132	535901

* assembled at time of order

Guide Bar Mount Assembly – Class I, II and III

Manual Lock

Complete illustration: Class I, II and III page 66

Required Tools

Class I..... 2 mm or 2.5 mm hex wrench
Class II..... 4 mm hex wrench
Class III..... 4 and 5 mm hex wrench
Parker Super O-Lube O-ring Lubricant

Disassembly Procedure

1. Disconnect air supply hose at the manifold.
2. Remove knifeholder from guide bar.
3. Remove blade cartridge from control body.
4. Place control body on workbench.
5. Remove gib by loosening and removing the two socket head cap screws.
6. Remove the guide bar mount assembly by loosening and removing the four socket head cap screws.

Guide Bar Mount (Manual Lock) disassembly is complete.

To Reassemble Guide Bar Mount (Manual Lock)

1. Reinstall the guide bar mount assembly on the control body and tighten the fasteners to the appropriate torque value:
Class I (M4) — 2.1 ft·lbs (2.85 Nm)
Class II (M5) — 4.3 ft·lbs (5.83 Nm)
Class III (M6) — 7.3 ft·lbs (9.89 Nm)
2. Place the control body on the guide bar and reassemble the gib with two socket head cap screws. Refer to *Knifeholder Installation* on page 15. Tighten fasteners to the appropriate torque value:
Class I (M4) — 2.1 ft·lbs (2.85 Nm)
Class II (M5) — 4.3 ft·lbs (5.83 Nm)
Class III (M5) — 4.3 ft·lbs (5.83 Nm)
3. Reinstall blade cartridge on control body.

Recommended Maintenance

If the brake shoe becomes lodged inside the body mount, remove the brake shoe. Wipe off and lubricate the brake shoe o-ring with *Parker Super O-Lube*.

Guide Bar Mount Assembly – Class I, II and III

Pneumatic Lock

Complete illustration: Class I, page 67
Class II and III, 68

Required Tools

Class I..... 2 mm or 2.5 mm hex wrench
Class II..... 4 mm hex wrench
Class III..... 4 and 5 mm hex wrench

Disassembly

Class I

1. Disconnect air supply hose at the manifold.
2. Remove knifeholder from guide bar.
3. Remove blade cartridge from control body.
4. Place control body on workbench.
5. Remove gib by loosening and removing the two socket head cap screws.
6. Remove the guide bar mount assembly by loosening and removing the four socket head cap screws.

Class II and III

1. Disconnect air supply hose at the manifold.
2. Remove knifeholder from guide bar.
3. Remove blade cartridge from control body.
4. Place control body on workbench.
5. Remove gib by loosening and removing the two socket head cap screws.
6. Remove the guide bar mount assembly by loosening and removing the four socket head cap screws.

Guide Bar Mount (Pneumatic Lock) disassembly is complete.

To Reassemble the Guide Bar Mount

Class I

1. Reinstall the guide bar mount assembly on the control body and tighten fasteners to 2.1 ft-lbs (2.85 Nm).
2. Place the control body on the guide bar and reassemble the gib with two socket head cap screws. Refer to knifeholder installation on page 16. Tighten fasteners to 2.1 ft-lbs (2.85 Nm).
3. Reinstall blade cartridge on control body.

Class II and III

1. Reinstall the guide bar mount assembly on the control body and tighten fasteners:
Class II (M5) — 4.3 ft-lbs (5.83 Nm)
Class III (M6) — 7.3 ft-lbs (9.89 Nm)
2. Place the control body on the guide bar and reassemble the gib with two socket head cap screws. Refer to knifeholder installation on page 16. Tighten fasteners to 4.3 ft-lbs (5.83 Nm).
3. Reinstall blade cartridge on control body.

KNIFEHOLDER DISASSEMBLY AND MAINTENANCE

Guide Bar Mount Assembly – Class I, II and III

Easy Glider

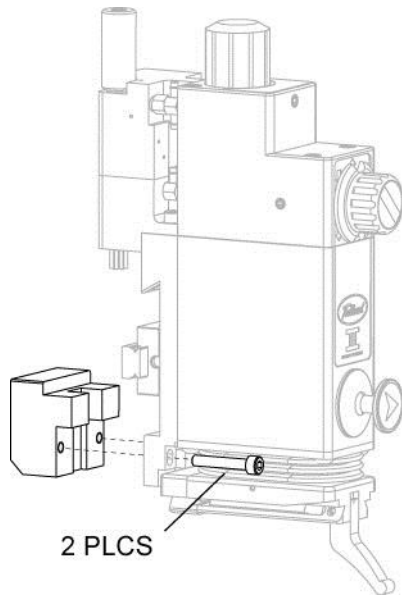

1. Remove the stop block. (4 mm hex drive)

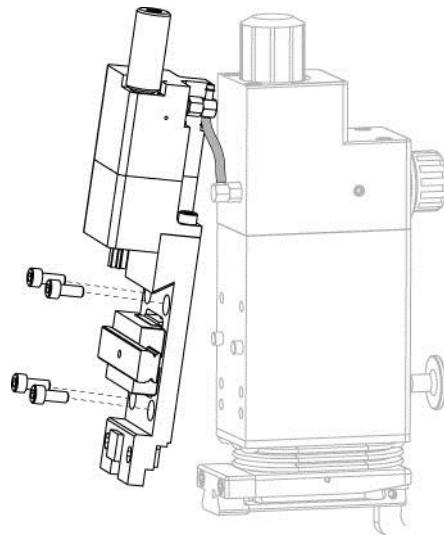

2. Remove the 4 screws in the backplate. (4 mm hex drive)
3. Gently pry the backplate off: the mounting assembly will be free to rotate away from the control body to access the bearing mount screws.

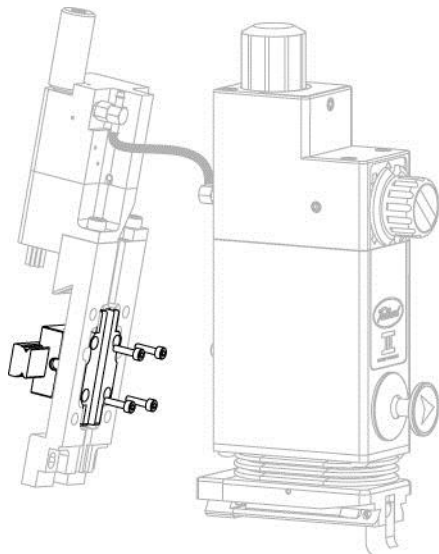

4. Remove the 4 screws in the bearing retainer. (2.5 mm hex drive)

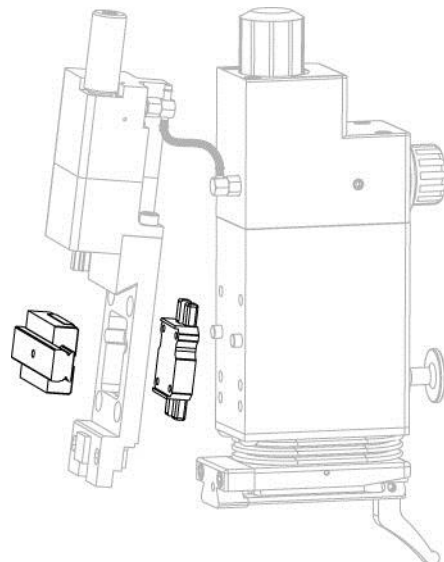

5. The bearing is free to remove.
6. Reassemble the knifeholder with the new bearing.

KNIFEHOLDER DISASSEMBLY AND MAINTENANCE

Dovetail Assembly – Class I, II and III

Note: It is not necessary to remove the dovetail assembly from the control body to replace the o-rings that interface with the blade cartridge.

Complete illustration: Class I, page 52
Class II and III, page 58

Required Tools

2 mm or 2.5 mm hex wrench

Small flat blade screwdriver

Small needlenose pliers

External air supply to extend knifeholder

Class I..... 10 mm thin open end wrench

Class II..... 16 mm thin open end wrench

Class III..... 25 mm thin open end wrench

} or thin slip-joint pliers

Disassembly

All Classes

1. Disconnect air supply hose at the manifold.
2. Remove knifeholder from guide bar.
3. Remove blade cartridge from control body.
4. Place control body on workbench.
5. Make sure function control knob is in the red (retract) arrow position.
6. Using small flat blade screwdriver, carefully pry off and remove depth control knob cap.
7. Remove the locking cap screw and washer from inside the depth control knob.
8. Remove depth control knob by hand, rotating counterclockwise.
 - Class I:** Remove the depth control spring and two flat washers; go to Step 9.
 - Class II and III:** Spring not accessible; go to Step 9.
9. Extend the knifeholder:
 - Class I:** No air supply needed. By hand, pull the dovetail assembly out of the control body.
 - Class II and III:** With external air supply set at approximately 30 psi and the function control knob in the yellow (setup) or green (run) arrow position, extend the dovetail assembly.
10. Lift or remove the bellows.
11. Mark the location of the colored hoses for your model. Refer to the Air Flow Schematics starting on page 50.
12. Using small needlenose pliers, detach the hoses from the air supply fittings mounted to the dovetail. Hold the hose firmly **above** (not on) the fittings and pull off, being careful not to rupture hoses. **Note:** Air will flow from the disconnected hoses (Class II and III).
13. With the dovetail assembly extended, place an open-end wrench on the flats of the piston guide rod and turn counterclockwise to loosen it completely from the dovetail.
 - Caution!** Do not damage the air supply fittings.
 - Note:** It is not necessary to remove the cant key guide rod from the dovetail assembly.
14. Retract the piston guide rod after dovetail assembly removal is complete:
 - Class I:** Push piston guide rod by hand.
 - Class II and III:** Turn function control knob to red (retract) arrow position to retract the piston guide rod.

To Reassemble Dovetail Assembly

Class I

1. Pulling by hand, extend the piston guide rod.
2. Apply *LOCTITE 242* to the threads of the piston guide rod.
3. Fasten the dovetail assembly to the extended piston guide rod and tighten to 12 ft·lbs (16.26 Nm).
Caution! Be careful not to damage the dovetail air supply fittings.
4. Reinstall air hoses as shown on the Air Flow Schematic on page 50.
5. Replace the bellows.
6. With the function control knob in the red (retract) position, push the dovetail assembly into the lower body and reinstall the flat washers, return spring and depth control knob.
7. Rotate the depth control knob clockwise far enough to allow the flat washer and socket head cap screw to lock against the stroke stop rod, capturing the depth control knob.
8. Reinstall the depth control knob cap.
9. Verify half and full stroke functionality before reinstalling the unit for operation.

Class II and III

1. Extend the piston guide rod using the function control knob in the yellow (setup) or green (run) position.
2. Apply *LOCTITE 242* to the threads of the piston guide rod.
3. Fasten the dovetail assembly to the extended piston guide rod and tighten to the appropriate torque value:
Class II — 35 ft·lbs (47.43 N·m)
Class III — 70 ft·lbs (94.85 N·m)
Caution! Be careful not to damage the dovetail air supply fittings when tightening the piston guide rod to the dovetail.
4. Reinstall the air hoses as shown on the Air Flow Schematic on page 50.
5. Reinstall the bellows.
6. With the hoses connected and the bellows in place, turn the function control knob to the red (retract) position.
7. Rotate the depth control knob clockwise far enough to allow the flat washer and socket head cap screw to lock against the stroke stop rod, capturing the depth control knob.
8. Reinstall the depth control knob cap.
9. Verify half and full stroke functionality before reinstalling the unit for operation.

Upper Body And Piston Assemblies – Class I

Complete illustration: Class I, page 52

Required Tools

Class I..... 2.5 mm hex wrench
Parker Super O-Lube O-ring Lubricant
Lubriplate EMB Polymer Grease (L0148-098)

Disassembly

1. Disconnect air supply hose at the manifold.
2. Remove control body from guide bar.
3. Remove blade cartridge from control body.
4. Place control body on workbench.
5. Remove dovetail assembly (41).
6. Remove guide bar mount assembly:
with pneumatic lock p. 67
with manual lock removal not required
7. Remove four socket head cap screws that attach upper and lower bodies to each other.
8. Lay control body flat on one side and carefully push (toward upper body) the piston guide rod into and through the guide rod bushing. This allows simultaneous removal of both the upper body and piston assemblies from the lower body.

Note: The upper body and piston assemblies are connected by three internal coiled hoses. Be careful not to disconnect, rupture or loosen these connections.

Upper Body, Lower Body and Piston disassembly is complete.

Recommended Maintenance

- Lubricate piston guide rod with *Lubriplate EMB Polymer Grease (L0148-098)*.
- Inspect and replace the piston o-ring, if necessary. Lubricate* the new o-ring before installing.
- Lubricate* stroke stop rod.

*use *Parker Super O-Lube*

To Reassemble Upper Body and Piston Assemblies – Class I

1. Make sure the body gasket is in place on the lower body.
2. Carefully insert the attached assemblies into the lower body assembly.
Caution: When guiding the piston guide rod thru the bushing be careful not to trap or kink the three hoses attached to the lower side of the piston.
3. Secure the upper body with fasteners and torque to 1 ft·lb (1.35 Nm).
4. Extend the piston assembly by pulling out the piston guide rod. Ensure that the attached air hoses are protruding through the lower body.
5. Attach the dovetail assembly (p. 42).
6. Reassemble the guide bar mount with pneumatic lock assembly (p. 39).
7. Attach the air supply hose and blade cartridge.
8. Verify blade cartridge half and full stroke functionality before reinstalling the unit for operation.

Lower Body Assembly – Class I

Complete illustration: Class I, page 52

Required Tools

Class I..... 2 mm hex wrench
Lubriplate EMB Polymer Grease (L0148-098)

Disassembly

1. Disconnect air supply hose at the manifold.
2. Remove knifeholder from guide bar.
3. Remove blade cartridge from control body.
4. Place control body on workbench.
5. Remove dovetail assembly (p. 41).
6. Remove guide bar mount with pneumatic lock assembly (p. 39).
7. Remove upper body and piston assemblies (p. 43).
8. Loosen four socket head cap screws.
9. Remove the retainer flange.
10. Remove piston guide rod bushing if replacement is necessary.
Note: The piston guide rod bushing is ceramic coated and will provide years of service under normal operating conditions.

Lower body disassembly is complete.

Recommended Maintenance

Lubricate piston guide rod bushing with *Lubriplate EMB Polymer Grease (L0148-098)*.

To Reassemble Lower Body

1. Replace the piston guide rod bushing into the lower body and fasten the flange retainer in place with the four socket head cap screws.
2. Reassemble the upper and piston body assemblies (p. 43).
3. Reassemble the dovetail assembly (p. 42).
4. Reassemble the guide bar mount with pneumatic lock assembly (p. 39).
5. Reinstall the blade cartridge (p. 28).
6. Attach the air supply hose.
7. Verify blade cartridge half and full stroke functionality before reinstalling the unit for operation.

KNIFEHOLDER DISASSEMBLY AND MAINTENANCE

Upper Body, Lower Body, and Piston Assemblies – Class II and III

Complete illustration: Class II and III, page 58

Required Tools

Class II..... 3 mm hex wrench

Class III..... 4 mm hex wrench

Parker Super O-Lube O-ring Lubricant

Lubriplate EMB Polymer Grease (L0148-098)

Disassembly

Class II and III

1. Disconnect air supply hose at the manifold.
2. Remove knifeholder from guide bar.
3. Remove blade cartridge from control body.
4. Place control body on workbench.
5. Remove dovetail assembly (p.41).
6. Remove guide bar mount assembly:
 - with pneumatic lock p. 39
 - with manual lock..... removal not required
7. Carefully remove the flange retainer and spring.
Caution! The flange retainer is under spring pressure. Hold the flange retainer firmly to the lower body when removing the four fasteners.
8. Remove the four socket head cap screws that attach the upper and lower bodies to each other.
9. Lay control body flat on one side and carefully push (toward upper body) the piston guide rod into and through the guide rod bushing. This allows simultaneous removal of both the upper body and piston assemblies from the lower body.
Note: The Upper Body and Piston assemblies are connected by three internal coiled hoses. Be careful not to disconnect, rupture or loosen these connections.

Upper Body and Piston disassembly is complete.

Recommended Maintenance

- Lubricate piston guide rod with *Lubriplate EMB Polymer Grease (L0148-098)*.
- Inspect and replace the piston o-ring, if necessary. Lubricate* new o-ring before installing.
- Inspect piston spring and return spring support and replace if excessively worn.
- Lubricate* stroke stop rod.

*Use *Parker Super O-Lube*.

(Reassembly on next page.)

To Reassemble Upper Body, Lower Body, and Piston Assemblies – Class II and III

1. Make sure the body gasket is in place on the lower body.
2. Carefully insert the upper body and piston assemblies into the lower body assembly from the top side.
3. Secure the upper body with fasteners to the lower body and tighten to torque values:
Class II — 2.1 ft.lb (2.85 Nm)
Class III — 4.3 ft.lb (5.83 Nm)
4. With the return spring attached to the flange retainer, carefully and firmly press the flange retainer flush to the lower body and fasten with the retainer screws.
Caution! Ensure that hoses protrude out of the lower body.
5. Reinstall and rotate the depth control knob clockwise far enough to allow the flat washer and socket head cap screw to lock against the stroke stop rod, capturing the depth control knob.
6. Reinstall the depth control knob cap.
7. Apply and regulate air pressure to approximately 30 psi.
8. Extend the piston guide rod by placing the function control knob in the yellow (setup) or green (operate) arrow position.
9. Install the dovetail assembly (p. 42).
10. Reinstall the guide bar mount with pneumatic lock assembly (p. 39).
11. Reinstall blade cartridge (p. 28).
12. Attach air supply hose.
13. Verify blade cartridge half and full stroke functionality before reinstalling the unit for operation.

Function Control Knob Assembly – Class I, II and III

Complete illustration: Class I, page 52
Class II and III, page 58

Required Tools

Small flat screwdriver
4 mm hex wrench
Parker Super O-Lube O-ring Lubricant

Disassembly

1. Disconnect air supply hose at the manifold.
2. Remove knifeholder from guide bar.
3. Remove blade cartridge from control body.
4. Lay the control body on its backside on workbench.
5. Rotate the function control knob to the red (retract) arrow position.
Note: The function control knob disc should be at approximately the 10:00 position.
6. Remove the disc using a small flat blade screwdriver.
7. Pry off carefully – part is reusable.
8. Hold the knob firmly in the red (retract) position to keep it from rotating while removing the knob bolt. Turn the bolt counterclockwise to remove.
9. Carefully lift out the function control knob assembly: Note that it is in the red (retract) position.

Function Control Knob disassembly is complete.

Recommended Maintenance

Inspect the o-rings on the function control knob bolt for cracks or chips and replace if necessary.

To Reassemble

1. Apply a light coat of *Parker Super O-Lube* to the o-rings before reassembly.
2. Ensure the function control knob is in the same red (retract) position as when it was removed.
3. Hold knob firmly in position while reinstalling the bolt.
4. Tighten the bolt to 5.5 ft·lbs (7.45 Nm) for Class I, II, and III.

Class I

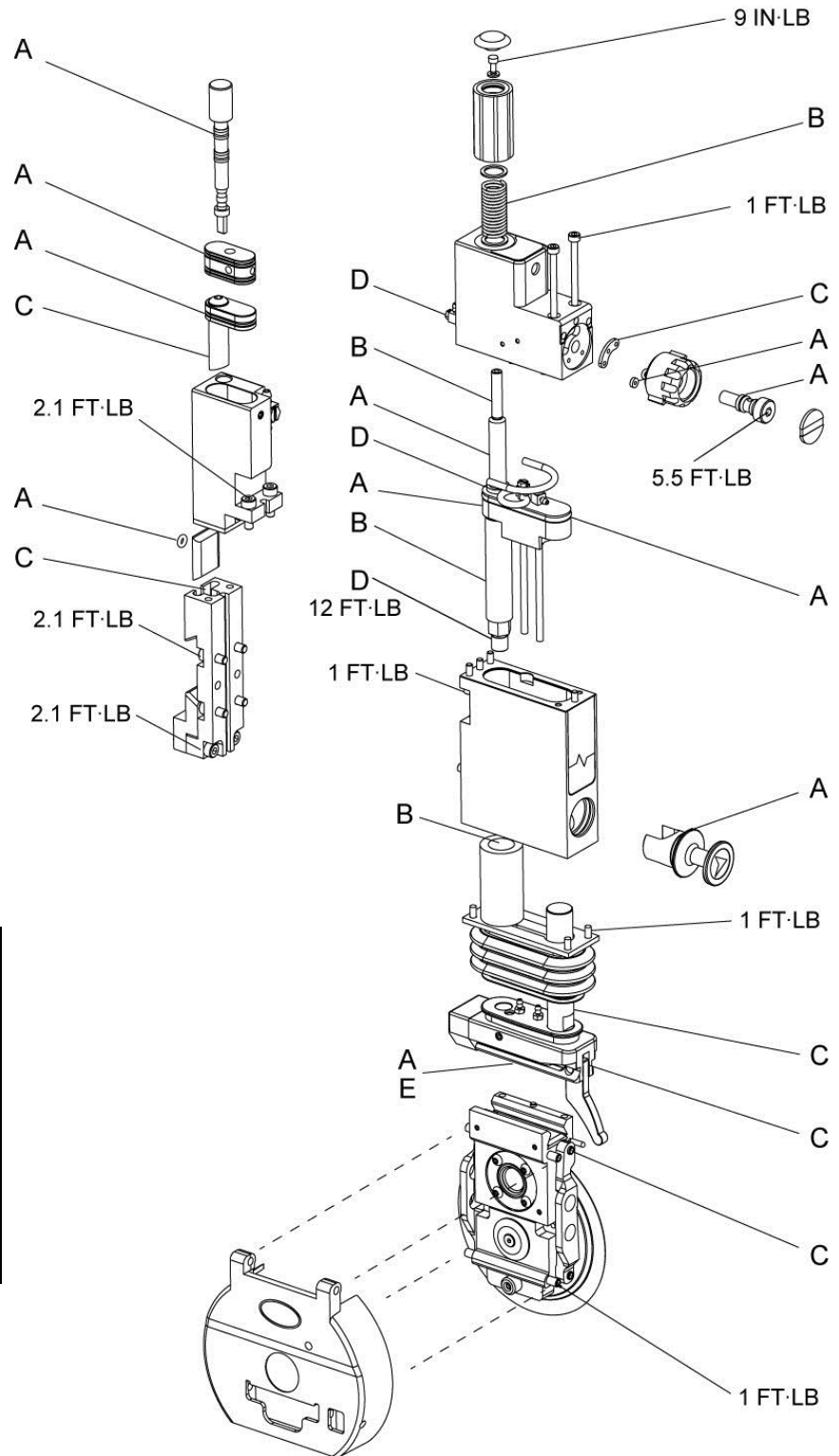

A	Parker Super O-Lube
B	Lubriplate EMB Polymer Grease L0148-098
C	Dow Corning 557 Silicone Dry Film Lubricant
D	Loctite 242
E	Loctite 480

Standard Cartridge shown

Class II and III

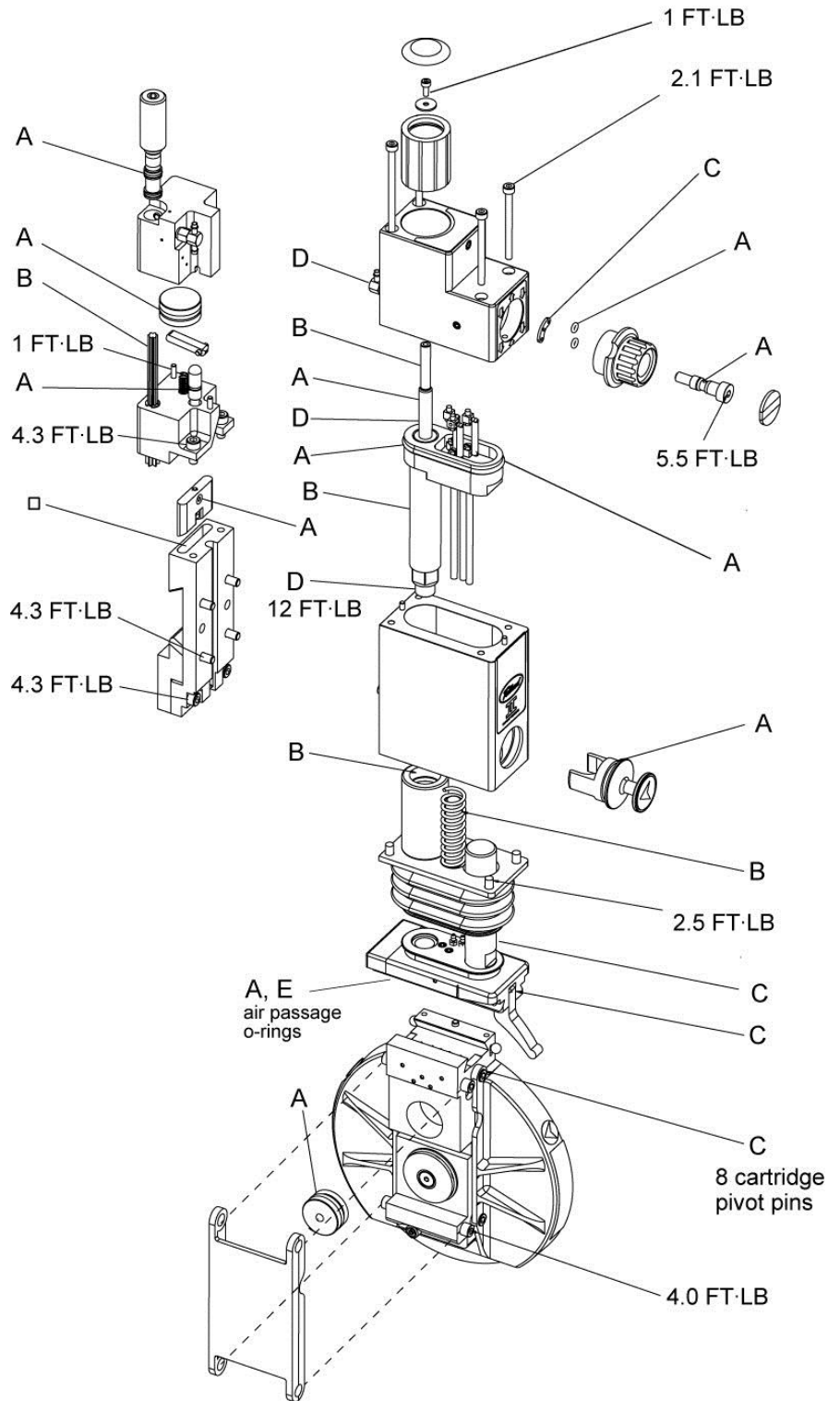

A	Parker Super O-Lube
B	Lubriplate EMB Polymer Grease L0148-098
C	Dow Corning 557 Silicone Dry Film Lubricant
D	Loctite 242
E	Loctite 480

AIR FLOW SCHEMATICS

Lift the bellows on Class I knifeholders to see hose layout and determine appropriate schematic.

Class I (before June 2003)

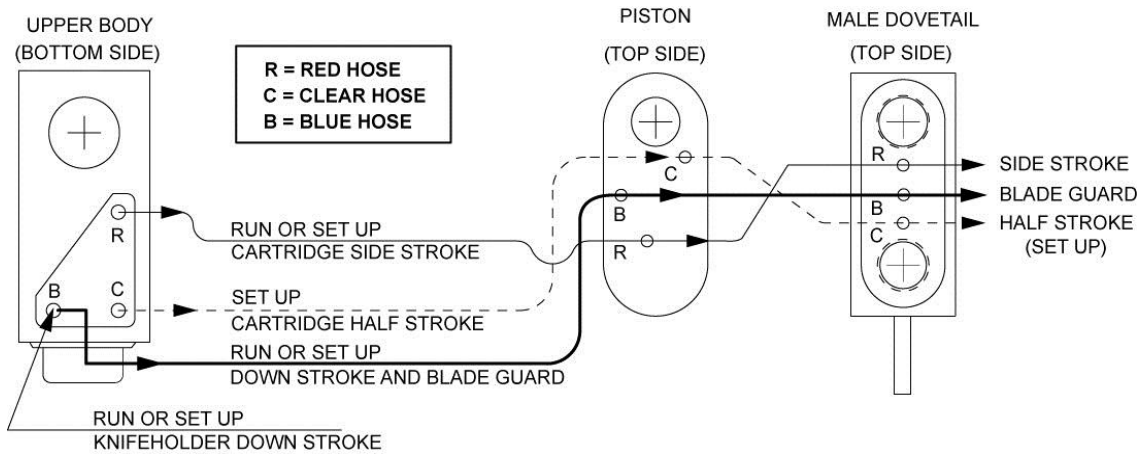

Class I (after June 2003)

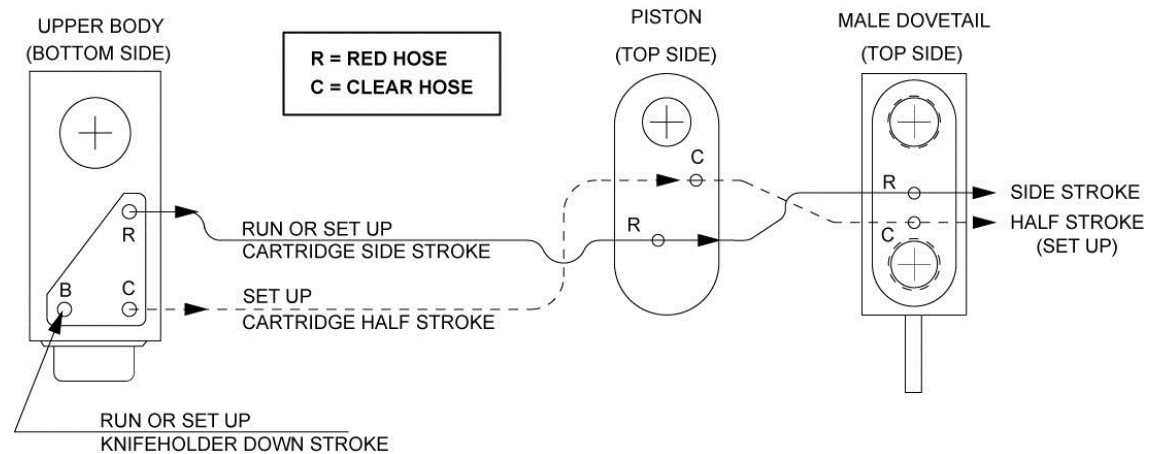

Class I (after Sept 2010)

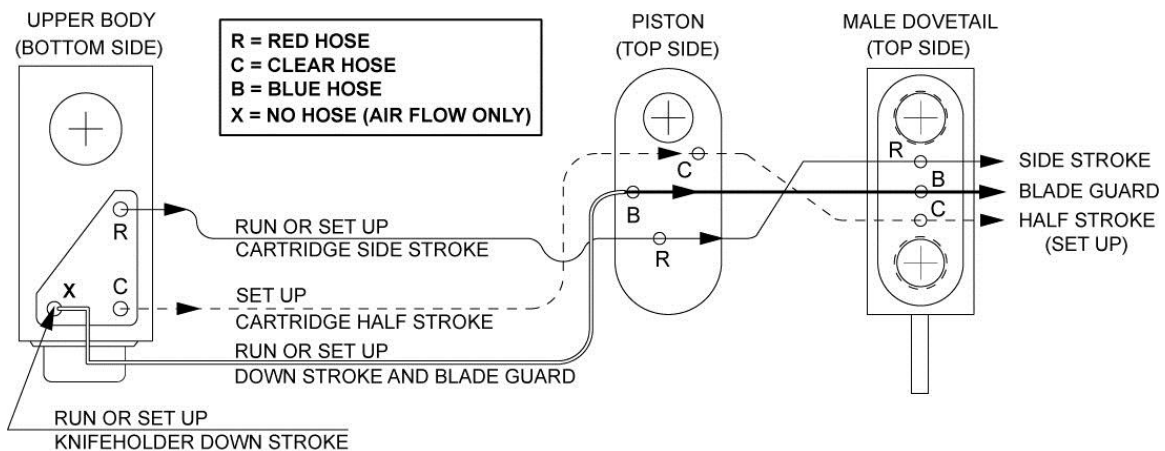

AIR FLOW SCHEMATICS

Class II

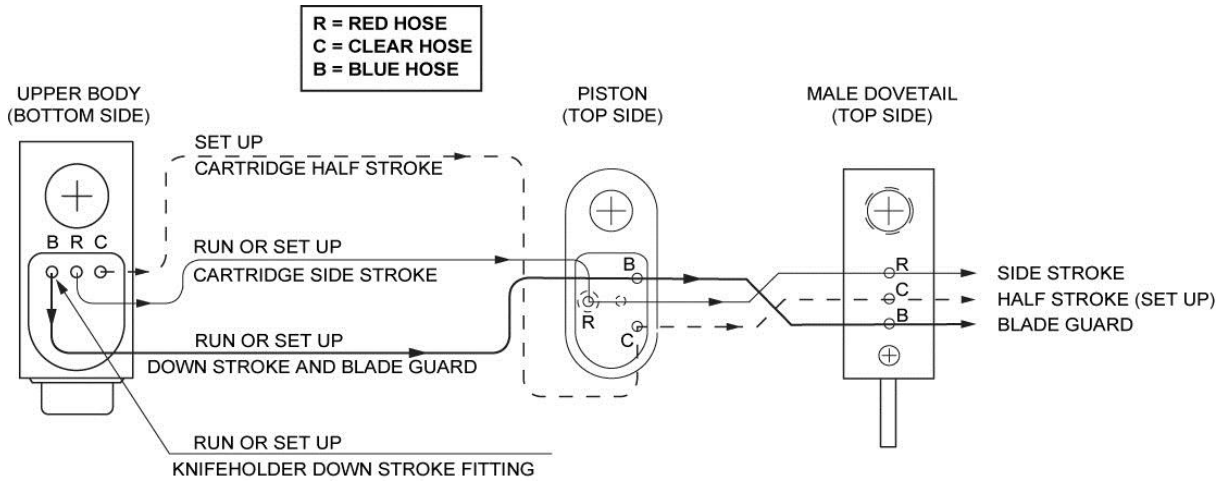

Class III

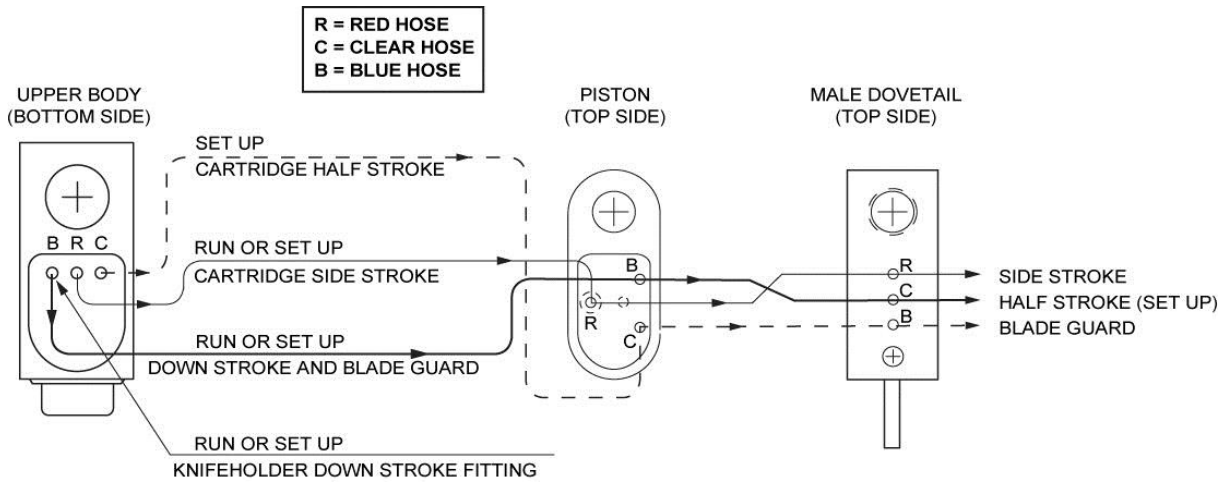

KNIFEHOLDER PARTS

Automatic Control Body

Class I – 536160

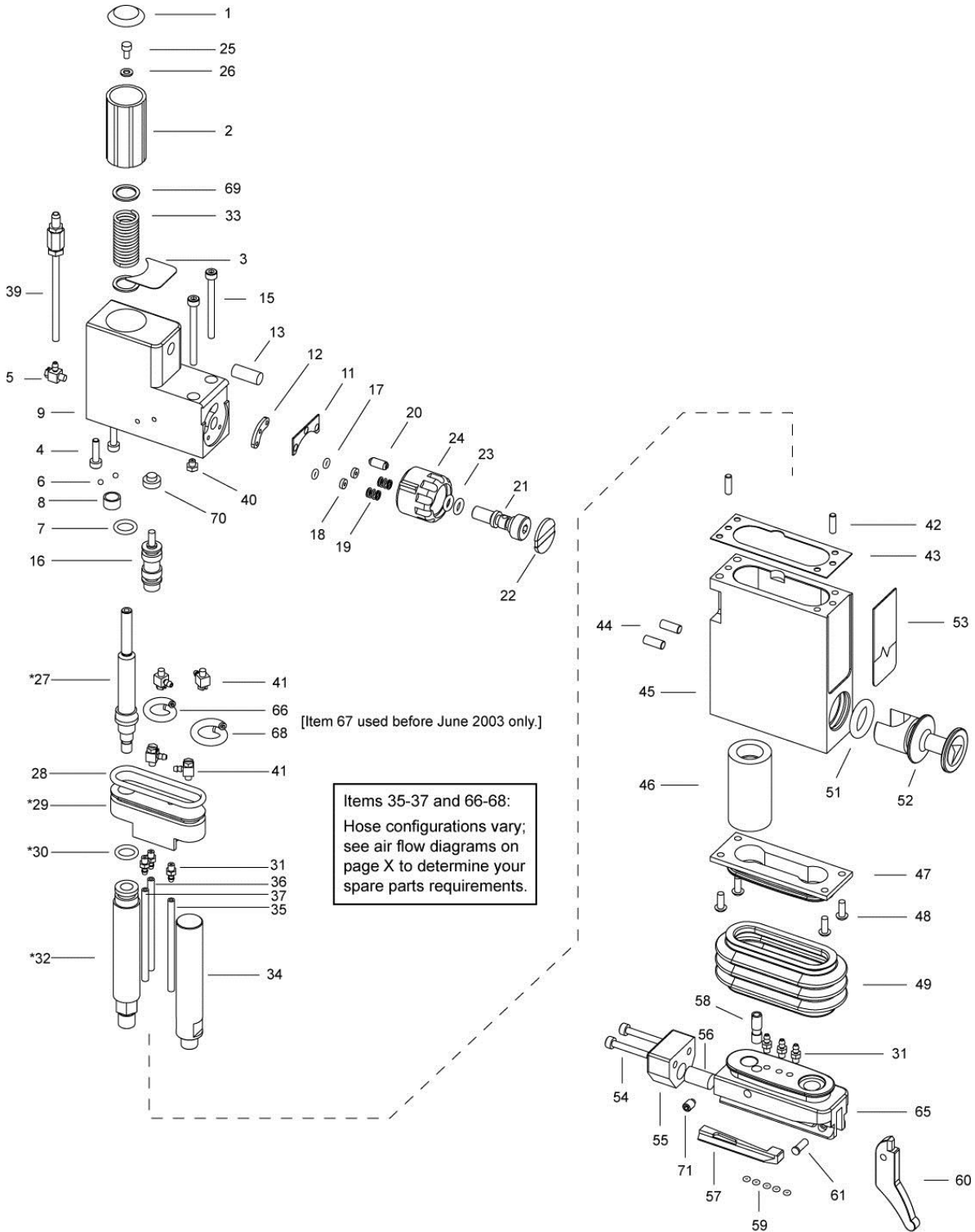

* Tidland recommends ordering these parts as the piston sub-assembly (see page 37).

KNIFEHOLDER PARTS

Automatic Control Body

536160

Item	Description	Class I	Qty
1	Depth Knob Cap	536161	1
2	Depth Control Knob	535334	1
3	Depth Control Label	548612	1
4	Soc Hd Cap Screw	133180	2
5	Air Fitting	528697	1
6	Steel Ball	554256	2
7	Valve O-ring	126119	1
8	Stroke Stop Rod Bushing	524998	1
9	Upper Body	563963	1
10	n/a	n/a	n/a
11	Upper Body Label	524993	1
12	Function Detent Pad	528779	1
13	Detent	528781	1
14	n/a	n/a	n/a
15	Soc Hd Cap Screw	536168	2
16	3-way Valve	528783	1
17	O-ring (set up knob bolt)	130827	2
18	Bushing	524992	2
19	Spring	130133	2
20	Detent	528780	1
21	Function Control Knob Bolt	563953	1
22	Function Control Knob Disc	536468	1
23	O-ring	126443	2
24	Function Control Knob	524991	1
25	Soc Hd Cap Screw	536165	1
26	Flat Washer	590063	1
27	Stroke Stop Rod	534810	1
28	O-ring (piston)	536164	1
29	Piston	524994	1
30	O-ring Piston Guide Rod	126119	1
31	Air Fitting	530101	6
32	Piston Guide Rod	560523	1
33	Return Spring	537767	1
34	Cant Key Guide Rod	560495	1
35	Air Hose (clear)	536162	1
36	Air Hose (red)	535153	1
37	Air Hose (blue)	132556	1

Item	Description	Class I	Qty
38	n/a	n/a	n/a
39	Hose Assembly	561042	1
40	Air Fitting	543822	1
41	Air Fitting	528697	4
42	Dowel Pin	549542	2
43	Gasket	524999	1
44	Dowel Pin	545123	2
45	Lower Body	524974	1
46	Piston Guide Rod Bushing	524977	1
47	Retainer Flange	524981	1
48	Button Head Cap Screw	132371	4
49	Bellows	535074	1
50	n/a	n/a	n/a
51	O-ring (cant key)	126112	1
52	Cant Key	call	1
53	Lower Body Label	536508	1
54	Cap Screw	536171	2
55	Stop Plate	526354	1
56	Spring	530189	1
57	Wedge Lock	524972	1
58	Guide Pin	535236	2
59	O-ring	536170	5
60	Lock/Unlock Lever	526355	1
61	Pivot Pin	561986	1
62	n/a	n/a	n/a
63	n/a	n/a	n/a
64	n/a	n/a	n/a
65	Dovetail	560569	1
66	Air Hose, coiled (red)	525000	1
*67	Air Hose, coiled (blue)	536163	1
68	Air Hose, coiled (clear)	561517	1
69	Flat Washer	525004	2
70	Valve Cap	524979	1
71	Setscrew	134011	1

* Used only on knifeholders manufactured before June 2003. See Air Flow Schematics on page 50.

KNIFEHOLDER PARTS

Automatic Blade Cartridge

Class I Standard – 547613

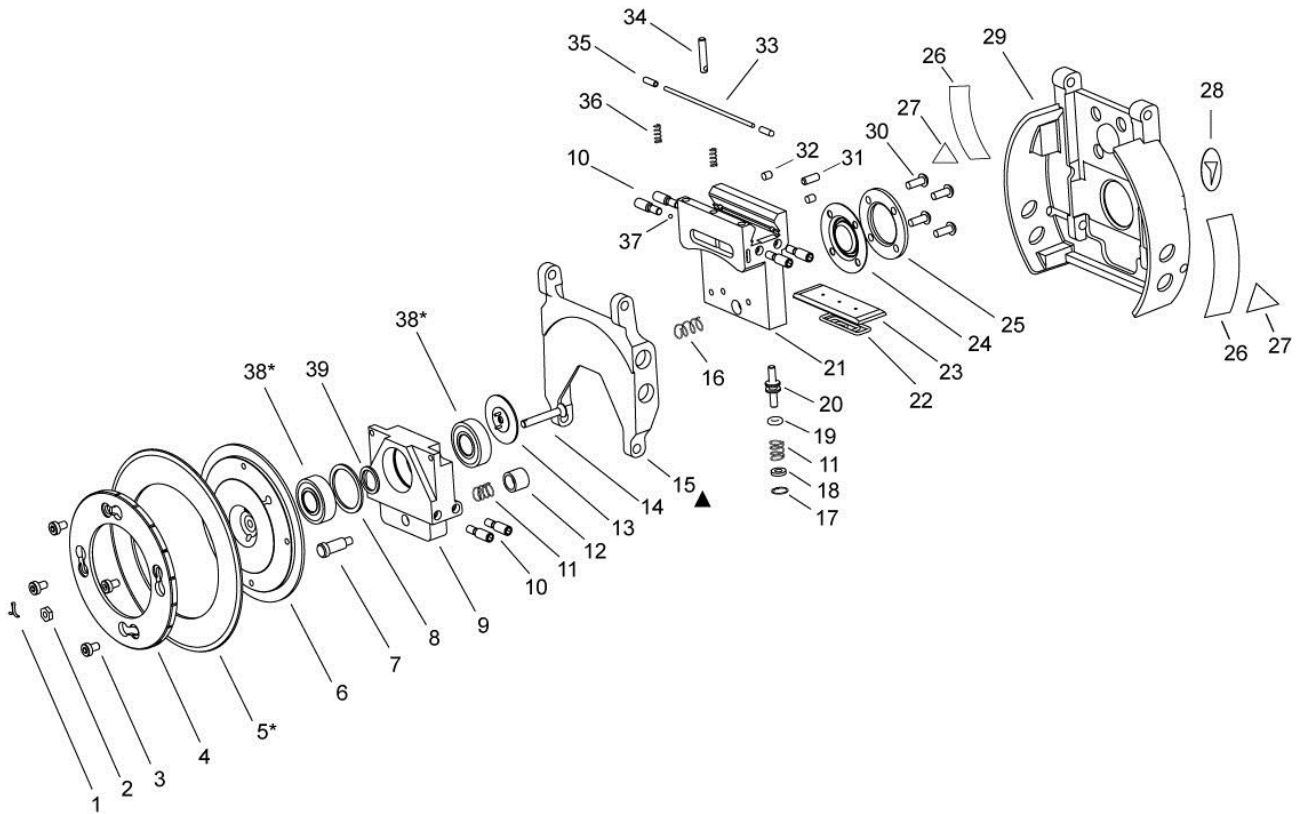

▲ The inboard strut arm was revised. Your part may not match the illustration, but the parts are completely interchangeable.

KNIFEHOLDER PARTS

Automatic Blade Cartridge

Class I Standard – 547613

Item	Description	Class I	Qty
1	Hair Pin	528673	1
2	Nylock Nut	528674	1
3	Soc Hd Cap Screw	635047	4
4	Blade Clamp	579833	1
* 5	Knife Blade	131937	1
6	Blade Hub	528671	1
7	Blade Lock Pin	133963	1
8	Bearing Snap Ring	528675	1
9	Bearing Housing	528667	1
10	Pivot Stud	545948	8
11	Set Stop Spring	528672	2
12	Blade Lock Cap	133962	1
13	Bearing Cap Assembly	528664	1
14	Flat Head Cap Screw	528668	1
15	Inboard Strut Arm	596436	1
16	Return Spring	552070	1
17	Set Stop Piston Snap Ring	528692	1
18	Set Stop Bushing	528687	1
19	Set Stop O-ring	130136	1
20	Set Stop Piston	528686	1
21	Dovetail Block	528679	1
22	D-seal	528682	1
23	D-seal Plate	528683	1
24	Diaphragm	528677	1
25	Diaphragm Plate	528678	1
26	Warning Label, ANSI	724239	2
27	Warning Label, ISO	724242	2
28	Cant Arrow Direction Label	547635	2
29	Outboard Strut	604563	1
30	Button Head Cap Screw	529354	4
31	Setscrew	564439	1
32	Setscrew	554156	2
33	Safety Latch Pin	528691	1
34	Safety Lock Pin	528681	1
35	Latch Pin Cap	528680	2
36	Safety Lock Spring	131119	2
37	Steel Ball	539093	1
* 38	Ball Bearing	528663	2
39	Bearing Spacer	528669	1

* Recommended Spare Parts

KNIFEHOLDER PARTS

Automatic Blade Cartridge

Class I w/ Pneumatic 360° Blade Guard – 718312

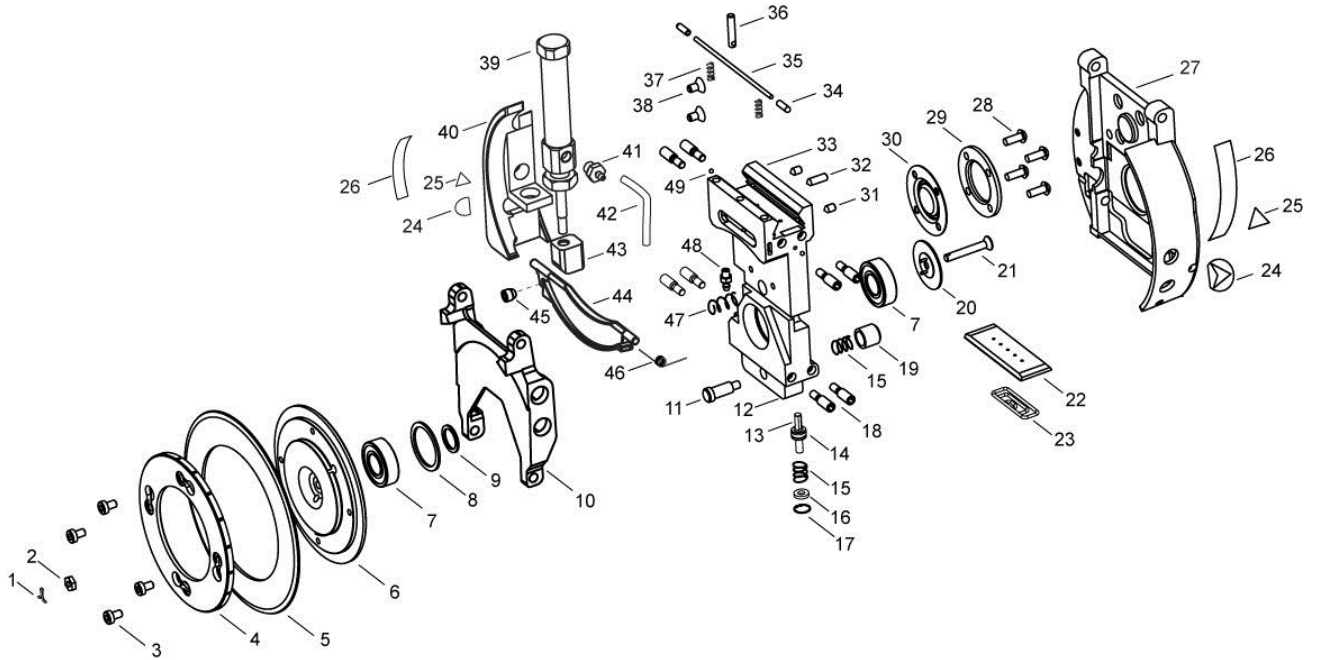

KNIFEHOLDER PARTS

Automatic Blade Cartridge

Class I w/ 360° Blade Guard – 718312

Item	Description	Class I	Qty
1	Hair Pin	528673	1
2	Nylock Nut	528674	1
3	Soc Hd Cap Screw	635047	4
4	Blade Clamp	579833	1
* 5	Knife Blade	131937	1
6	Blade Hub	528671	1
* 7	Ball Bearing	528663	2
8	Bearing Snap Ring	528675	1
9	Bearing Spacer	528669	1
10	Inboard Strut Arm	717825	1
11	Blade Lock Pin	133963	1
12	Bearing Housing	528667	1
13	Set Stop Piston	528686	1
14	O-ring (Parker 2-006)	130136	1
15	Set Stop Spring	528672	2
16	Set Stop Bushing	528687	1
17	Set Stop Piston Snap Ring	528692	1
18	Pivot Stud	545948	8
19	Blade Lock Cap	133962	1
20	Bearing Cap Assembly	528664	1
21	Flat Hd Cap Screw	528668	1
22	D-seal Plate	719522	1
23	D-seal	528682	1
24	Cartridge Arrow Label	547637	2
25	Warning Label, ISO	724242	2
26	Warning Label, ANSI	724239	2
27	Guard Strut	717820	1
28	Button Hd Cap Screw	529354	4
29	Diaphragm Plate	528678	1
30	Diaphragm	528677	1
31	Set Screw	554156	2
32	Set Screw	564439	1
33	Dovetail Block	734025	1
34	Safety Latch Pin Cap	528680	2
35	Safety Latch Pin	528691	1
36	Safety Lock Pin	528681	1
37	Safety Lock Spring	131119	2
38	Flat Head Cap Screw	132270	2
39	Air Cylinder w/ nut	718238	1
40	Mounting Block, Left	716998	1
41	Air Fitting Barb	561866	1
42	Air Hose, Clear	536162	a/r
43	Wedge Block	717080	1
44	Blade Guard Flap	716973	1
45	Set Screw, Special	728700	1
46	Torsion Spring	718235	1
47	Cartridge Return Spring	552070	1
48	Air Fitting Barb	530101	1
49	Steel Ball	539093	2

* Recommended spare parts

KNIFEHOLDER PARTS

Automatic Control Body

Class II – 530527

Class III – 528812

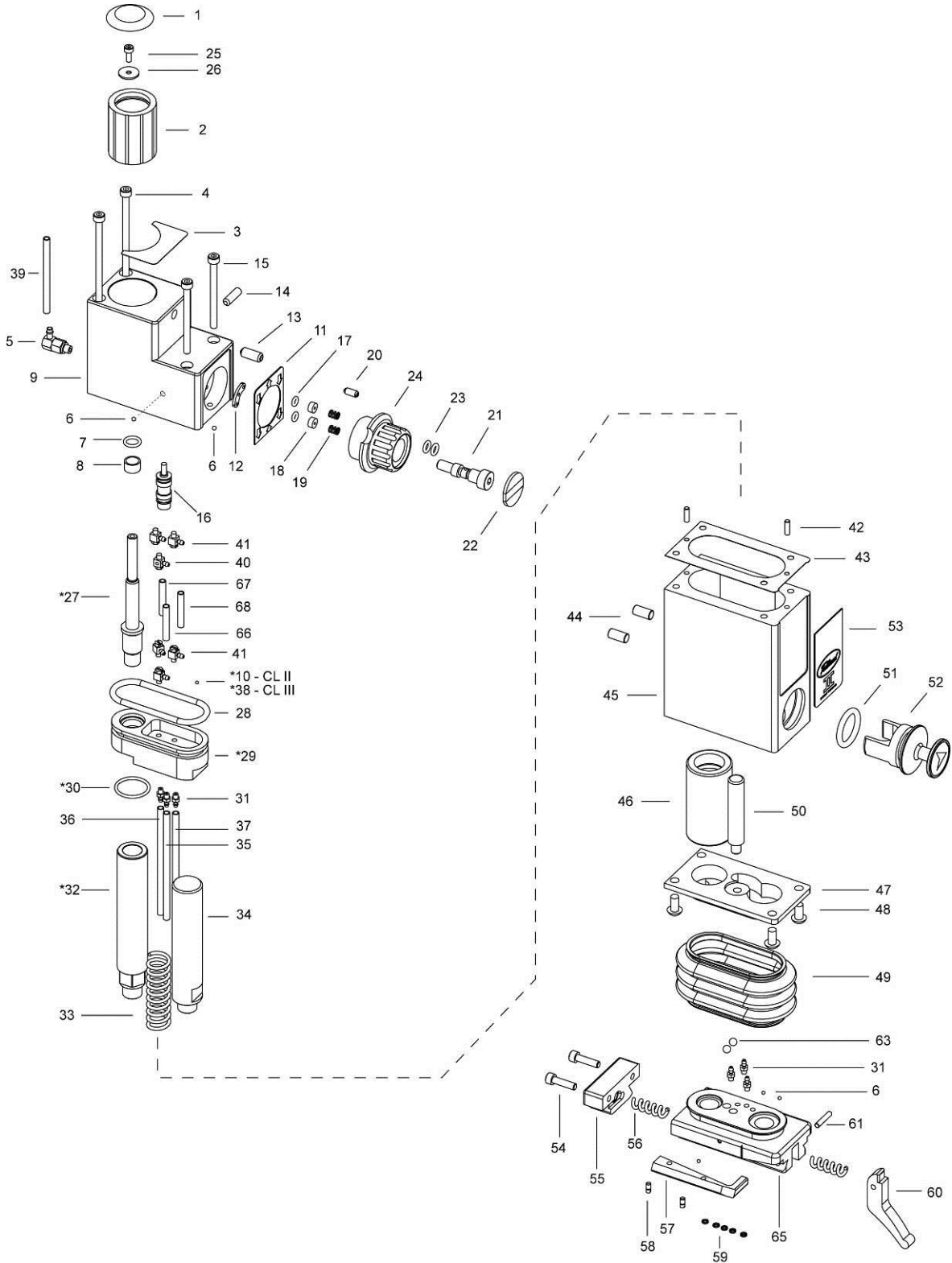

KNIFEHOLDER PARTS

Automatic Control Body

Class II – 530527

Class III – 528812

Item	Description	Class II	Qty	Class III	Qty
1	Depth Control Knob Cap	530186	1	530186	1
2	Depth Control Knob	530536	1	530536	1
3	Depth Control Label	548629	1	548637	1
4	Soc Hd Cap Screw	531126	2	130144	2
5	Air Fitting	251535	1	251535	1
6	Steel Ball. 3/32" dia	554256	5	554256	9
7	Valve O-ring	126119	1	126119	1
8	Stroke Stop Rod Bushing	524998	1	524998	1
9	Upper Body	530538	1	528814	1
10	Steel Ball, 1/16" dia	539093	1	n/a	–
11	Upper Body Label	528831	1	528826	1
12	Function Detent Pad	528779	1	528779	1
13	Detent	528781	1	528781	1
14	Setscrew	557274	1	558779	1
15	Soc Hd Cap Screw	531127	2	551477	2
16	3-way Valve	528783	1	528783	1
17	O-ring (setup knob bolt)	130136	2	130136	2
18	Bushing	130108	1	130108	1
19	Spring	130133	2	130133	2
20	Detent	528780	1	528780	1
21	Function Control Knob Bolt	528801	1	528801	1
22	Function Control Knob Disc	528825	1	528825	1
23	O-ring	126443	2	126443	2
24	Function Control Knob	528806	1	528806	1
25	Soc Hd Cap Screw	132483	1	132483	1
26	Washer	535183	1	535183	1
27	Stroke Stop Rod	557519	1	557519	1
28	O-ring (piston)	530352	1	536239	1
29	Piston	557526	1	558880	1
30	O-ring Piston Guide Rod	130186	1	536190	1
31	Air Fitting	530101	6	530101	6
32	Piston Guide Rod	557322	1	558948	1
33	Return Spring	535146	1	535146	1
34	Cant Key Guide Rod	557357	1	557357	1

Item	Description	Class II	Qty	Class III	Qty
35	Air Hose (clear)	536162	1	536162	1
36	Air Hose (red)	535153	1	535153	1
37	Air Hose (blue)	132556	1	132556	1
38	Steel Ball, 2 mm	n/a	–	557259	1
39*	Hose Assembly	128898	1	128898	1
40	Air Fitting	530351	1	530351	1
41	Air Fitting	528697	5	528697	5
42	Dowel Pin	549542	2	549542	2
43	Gasket	530715	1	528829	1
44	Dowel Pin	544998	2	544998	2
45	Lower Body	530533	1	528813	1
46	Piston Guide Rod Bushing	528787	1	528943	1
47	Retainer Flange	530528	1	528817	1
48	Cap Screw	250580	4	130467	4
49	Bellows	528809	1	528827	1
50	Return Spring Support	533775	1	533775	1
51	O-ring (cant key)	578331	1	578331	1
52	Cant Key	call	1	call	1
53	Lower Body Label	528830	1	528828	1
54	Cap Screw	132619	2	536135	2
55	Stop Plate	528808	1	529506	1
56	Spring	530189	2	539936	2
57	Wedge Lock	530714	1	528819	1
58	Guide Pin	528798	2	528798	2
59	O-ring	530193	5	530193	5
60	Lock/Unlock Lever	528800	1	528800	1
61	Pivot Pin	545406	1	545381	1
62	n/a	n/a	n/a	n/a	n/a
63	Ball, Stainless Steel	130167	2	n/a	n/a
64	n/a	n/a	n/a	n/a	n/a
65	Dovetail	557331	1	559031	1
66	Air Hose, coiled (red)	525000	1	525000	1
67	Air Hose, coiled (blue)	536163	1	536163	1
68	Air Hose, coiled (clear)	561517	1	561517	1

* Item 39: If your knifeholder mount has an external check valve, order 570730.

KNIFEHOLDER PARTS

Automatic Blade Cartridge

Standard

Class II – 524508

Class III – 535264

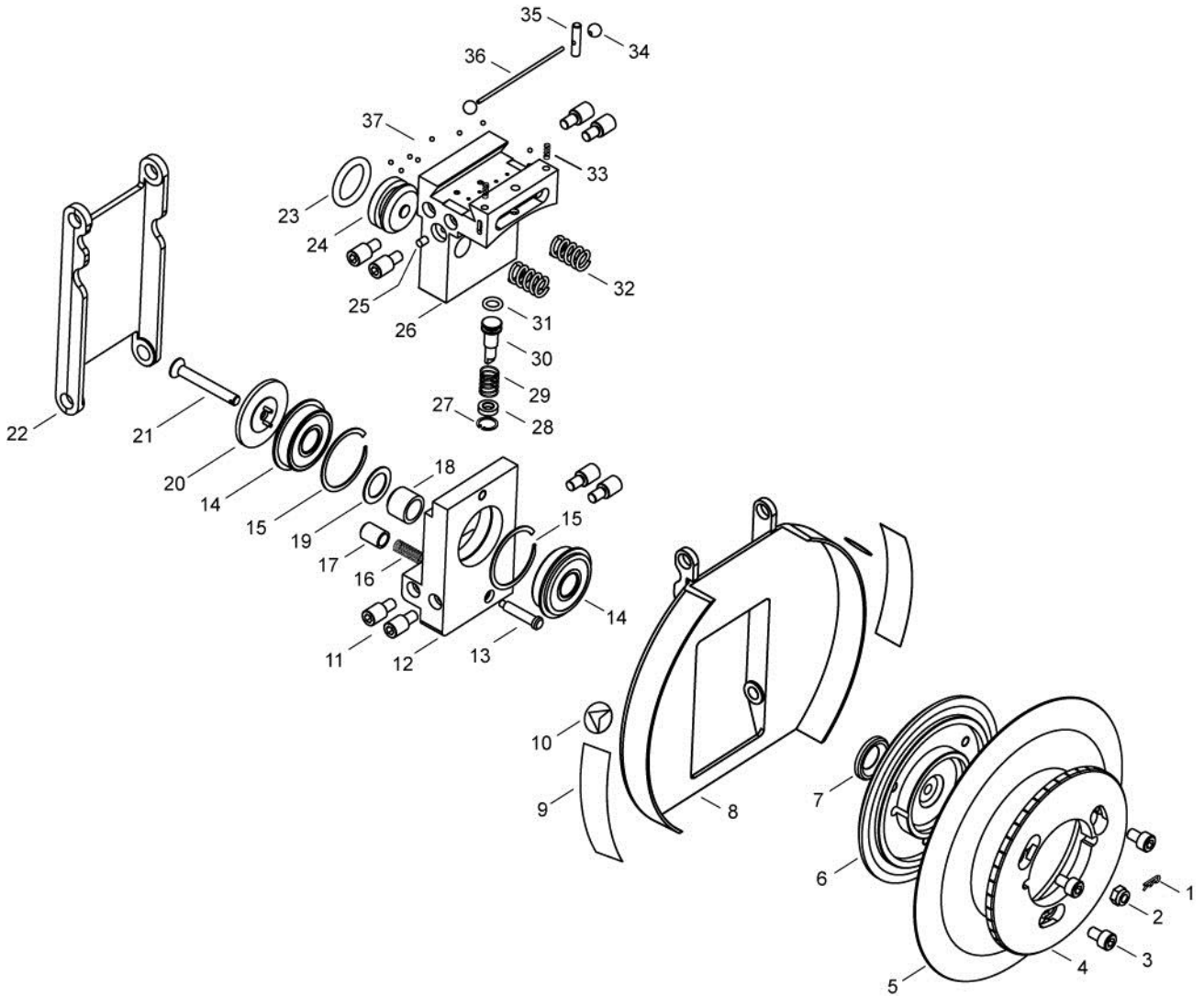

KNIFEHOLDER PARTS

Automatic Blade Cartridge

Standard

Class II – 524508

Class III – 535264

Item	Description	Class II	Qty	Class III	Qty
1	Hair Pin	133710	1	133710	1
2	Nylock Nut	133235	1	133235	1
3	Soc Hd Cap Screw	549838	3	130168	3
4	Blade Clamp	524543	1	135010	1
* 5	Knife Blade	128401	1	129833	1
6	Blade Hub	524544	1	135009	1
7	Shoulder Ring	631251	1	631251	1
8	Blade Guard	528098	1	536838	1
9	Warning Label	130921	2	130920	2
10	Cartridge Label	547635	2	547635	2
11	Pivot Stud	535263	8	535263	8
12	Bearing Housing	524542	1	536837	1
13	Blade Lock Pin	130172	1	130172	1
* 14	Ball Bearing	131121	2	131121	2
15	Snap Ring	134305	1	134305	2
16	Blade Lock Pin Spring	130179	1	130179	1
17	Blade Lock Cap	130173	1	130173	1
18	Bearing Spacer	n/a		133184	1
19	Shim	134304	1	134304	1
20	Bearing Cap Assembly	515511	1	515511	1
21	Bearing Retainer Cap Screw	524549	1	518520	1
22	Outboard Strut	528097	1	529808	1
23	Piston O-Ring	126479	1	126479	1
24	Piston	131108	1	131108	1
25	Set Screw	132615	1	528690	1
26	Dovetail Block	523492	1	529809	1
27	Snap Ring	132244	1	132244	1
28	Set Stop Bushing	524525	1	524525	1
29	Set Stop Spring	524528	1	524528	1
30	Set Stop Piston	524541	1	524541	1
31	Set Stop O-Ring	126193	1	126193	1
32	Return Spring	131118	2	131118	2
33	Safety Lock Spring	131119	2	131119	2
34	Safety Latch Knob	131116	2	131116	2
35	Safety Lock Pin	131114	1	131114	1
36	Safety Latch Pin	131115	1	132891	1
37	Steel Ball	557259	9	557259	5

* Recommended Spare Parts

KNIFEHOLDER PARTS

Automatic Blade Cartridge

With Pneumatic 360° Blade Guard

Class II – 548274

Class III – 548275

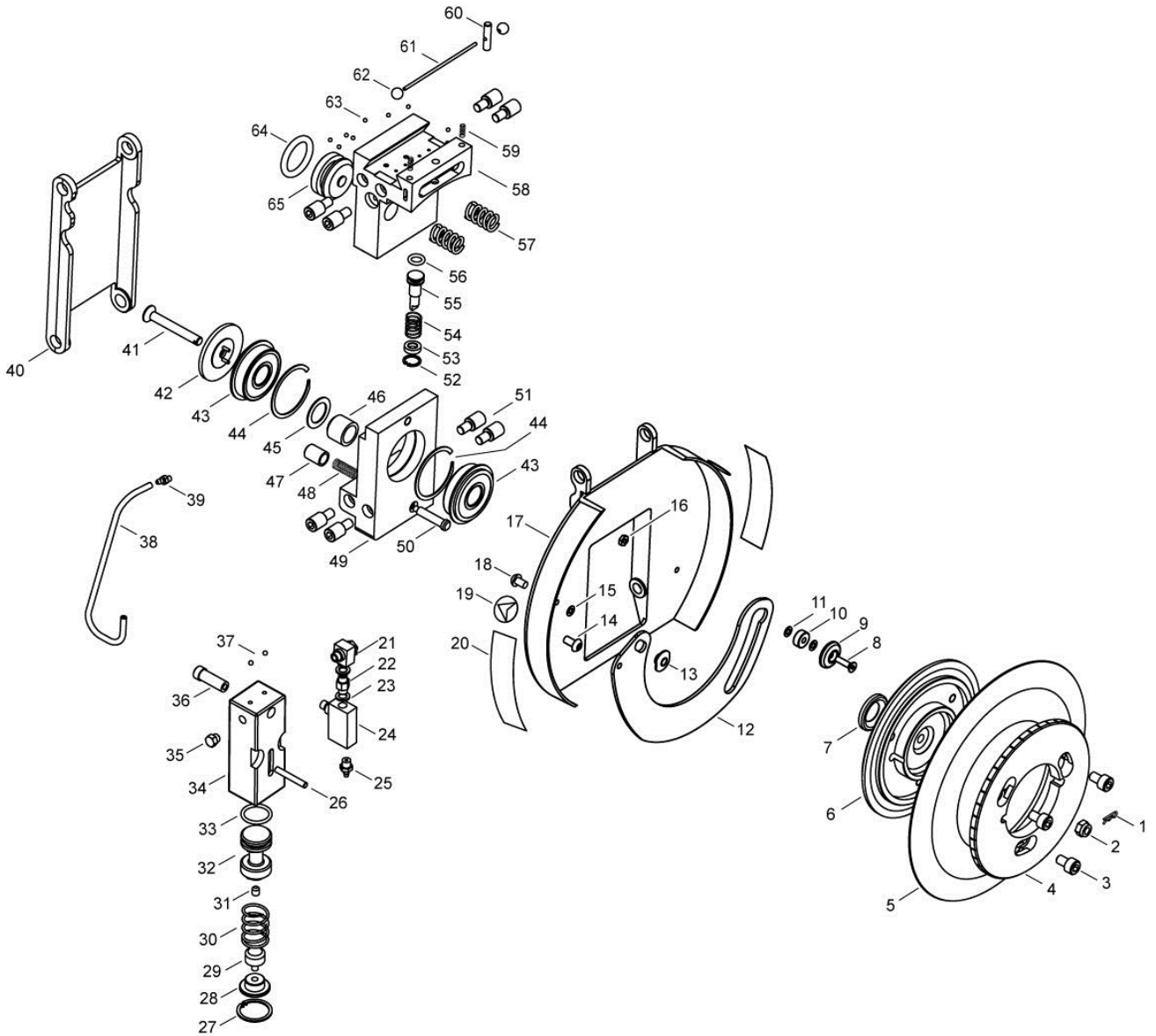

KNIFEHOLDER PARTS

Automatic Blade Cartridge

With Pneumatic 360° Blade Guard

Class II – 548274

Class III – 548275

Item	Description	Class II	Qty	Class III	Qty
1	Hairpin Cotter Pin	133710	1	133710	1
2	Stop Nut, M5	133235	1	133235	1
3	Soc Hd Cap Scr	549838	3	-	-
		-	-	130168	3
4	Blade Clamp	524543	1	135010	1
5	Knife Blade	128401	1	129833	1
6	Knife Blade Hub	524544	1	135009	1
7	Shoulder Ring	631251	1	631251	1
	Swing Guard Kit	578150		543587	
8	Flat Hd Scr	250007	1	250007	1
9	Keeper	567944	1	567944	1
10	Ball Bearing	567805	1	567805	1
11	Washer, Flat	568005	2	568005	2
12	Swing Plate	567965	1	575846	1
13	Pivot	567946	1	567946	1
14	Btn Hd Cpscr	130248	1	130248	1
15	Spacer	n/a	-	-	-
		-	-	572088	1
16	Jam Nut	528674	1	528674	1
17	Blade Guard Strut	567806	1	571762	1
18	Btn Hd Cpscr	131159	1	131159	1
19	Label, Cartridge Arrow	547635	2	547635	2
20	Label, Warning	130921	2	130920	2
	incl. Actuator Assembly	567502		567502	
21	Air Fitting, 90°	128899	1	128899	1
22	Coupling	567496	1	567496	1
23	Gasket, Nylon	133720	1	133720	1
24	Flow Control Valve	567497	1	567497	1
25	Air Fitting Barb	250423	1	250423	1
26	Dowel Pin	569469	1	571791	1
27	Snap Ring	567501	1	567501	1
28	Spring Retainer	567476	1	567476	1
29	Rubber Bumper	567500	1	567500	1
30	Spring, Compression	567495	1	567495	1
31	Set Screw	130147	1	130147	1
32	Piston	567459	1	567459	1
33	O-ring	111952	1	111952	1
34	Cylinder	567424	1	567424	1
35	Plug	130185	1	130185	1
36	Mounting Post	134169	1	134169	1
37	Bearing Ball	554256	2	554256	2

Item	Description	Class II	Qty	Class III	Qty
38*	Poly Tubing	132556	1	132556	1
39*	Air Fitting Barb	530101	1	530101	1
40	Strut Outboard	569439	1	571761	1
41	Flat Hd Cap Scr	524549	1	518520	1
42	Bearing Cap Assembly	515511	1	515511	1
43	Bearing	131121	1	131121	1
44	Snap Ring	134305	1	134305	2
45	Shim	134304	1	134304	1
46	Bearing Spacer	n/a		133184	1
47	Cap, Blade Lock Pin	130173	1	130173	1
48	Spring, Compression	130179	1	130179	1
49	Bearing Housing	524542	1	536837	1
50	Blade Lock Pin	130172	1	130172	1
51	Pivot Stud	535263	8	535263	8
52	Snap Ring	132244	1	132244	1
53	Bushing	524525	1	524525	1
54	Spring	524528	1	524528	1
55	Piston, Half Stop	524541	1	524541	1
56	O-ring	126193	1	126193	1
57	Spring, Compression	131118	2	131118	2
58	Dovetail	523492	1	529809	1
59	Spring, Compression	131119	2	131119	2
60	Safety Lock Pin	131114	1	131114	1
61	Safety Latch Pin	131115	1	132891	1
62	Safety Latch Pin Knob	131116	1	131116	1
63	Ball, Stainless Steel 2 mm	557259	9	557259	5
64	O-Ring	126479	1	126479	1
65	Piston	131108	1	131108	1

* supplied with Swing Guard Kit

Maintenance

- Accumulated dust and debris can affect the extension and retraction speeds of the blade guard. Clean the cartridge and blade guard assembly regularly using compressed air.
- Biannually, or as needed, remove the piston (32) from the cylinder. Clean and relubricate the parts using *Parker Super O-Lube* o-ring lubricant (or equivalent).
- Replace the o-ring or any worn parts as needed.

KNIFEHOLDER PARTS

360° Blade Guard – Mechanical

Class II — 766913

Class III — 766915

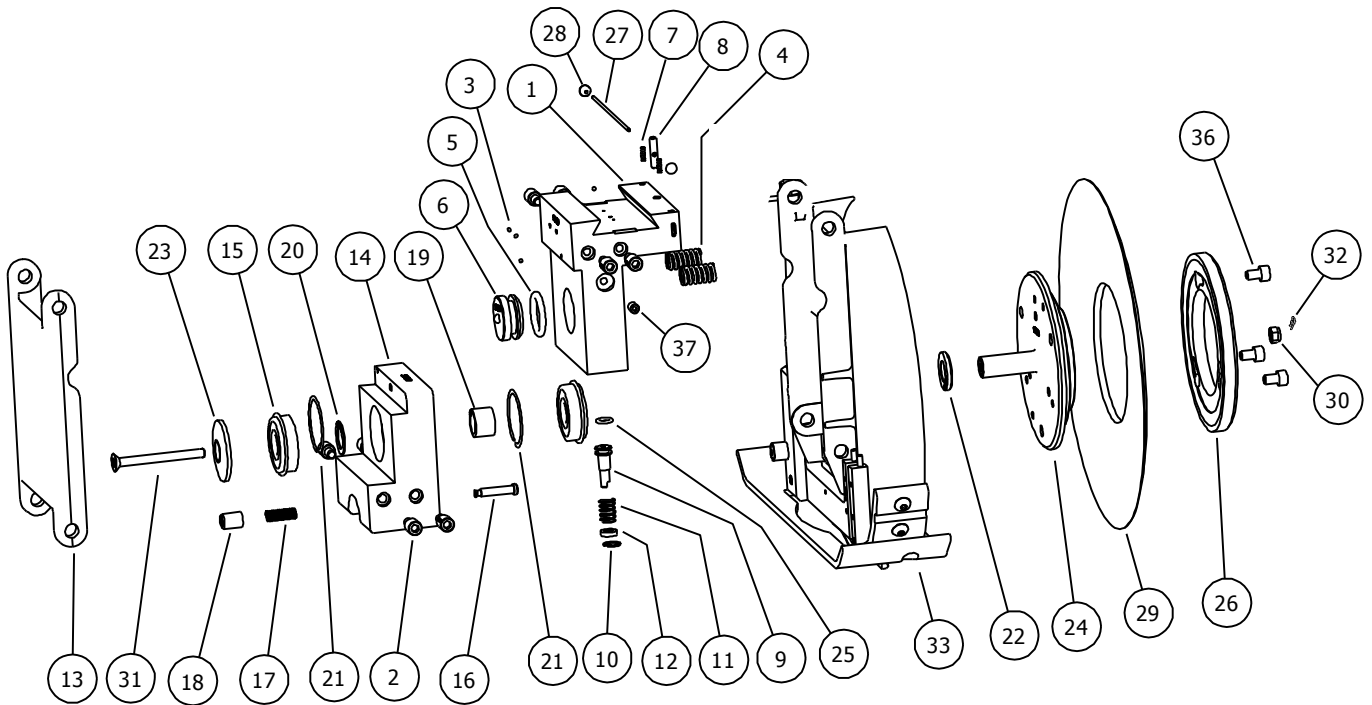

Item 33 is a sub-assembly that contains the following replaceable parts:

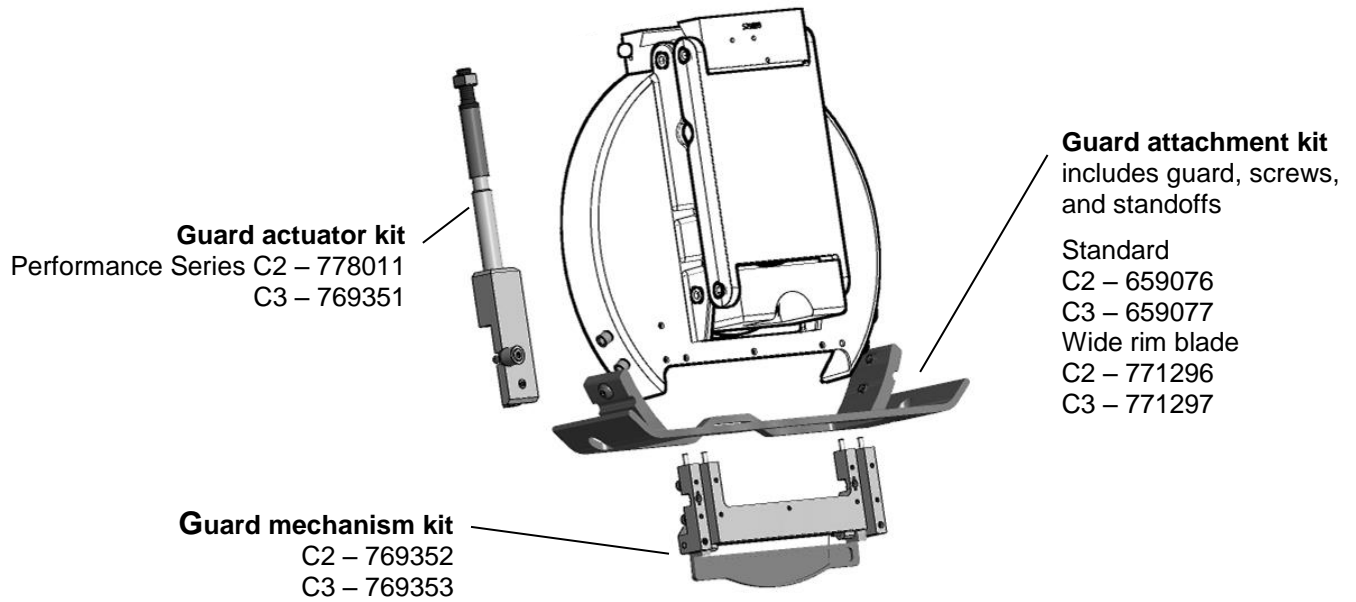

KNIFEHOLDER PARTS

360° Blade Guard - Mechanical

Class II — 766913

Class III — 766915

Item	Description	Class II	Qty	Class III	Qty
1	Dovetail block	523492	1	529809	1
* 2	Pivot stud	535263	8	535263	8
3	Steel ball 2 mm	557259	9	557259	5
4	Return spring	131118	2	131118	2
* 5	O-ring, piston (Parker 2-210-C557-70)	126479	1	126479	1
6	Piston	131108	1	131108	1
7	Safety lock spring	131119	2	131119	2
8	Safety lock pin	131114	1	131114	1
9	Piston	524541	1	524541	1
10	Snap ring (Truarc N5000-37)	132224	1	132244	1
11	Compression spring	524528	1	524528	1
12	Bushing	524525	1	524525	1
13	Strut, outboard	528098	1	529808	1
14	Bearing housing	524542	1	536837	1
* 15	Ball bearing	131121	2	131121	2
16	Blade lock pin	130172	1	130172	1
17	Blade lock spring	130179	1	130179	1
18	Blade lock cap	130173	1	130173	1
19	Bearing spacer	n/a	1	133184	1
20	Shim washer 3/4" OD x 1/2" ID x .025 thk	134304	1	134304	1
21	Snap ring (Smalley VH-125)	134305	1	134305	2
22	Shoulder ring	631251	1	631251	1
23	Bearing cap assembly	515511	1	515511	1
24	Blade hub	524544	1	135009	1
25	O-ring, set stop (Parker 2-010)	126193	1	126193	1
26	Blade clamp	524543	1	135010	1
27	Safety latch pin	131115	1	132891	1
28	Safety latch knob	131116	2	131116	2
* 29	Knife blade	128401	1	129833	1
30	Lock nut M5	133235	1	133235	1
31	Flat hd cap scr M5 x 60 mm lg (altered)	524549	1	518520	1
32	Hair pin	133710	1	133710	1
33	Blade guard actuator sub-assembly	778141	1	749589	1
34	Warning label	130921	2	130921	2
35	Cartridge arrow label	547635	2	547635	2
36	Soc hd cap scr M5 x 8 mm lg	549838	3	549838	3
37	Set scr M3 x 6 mm lg	132615	1	528690	1

* Recommended spare parts

KNIFEHOLDER PARTS

Guide Bar Mount Assembly – Manual Lock

Class I, II and III

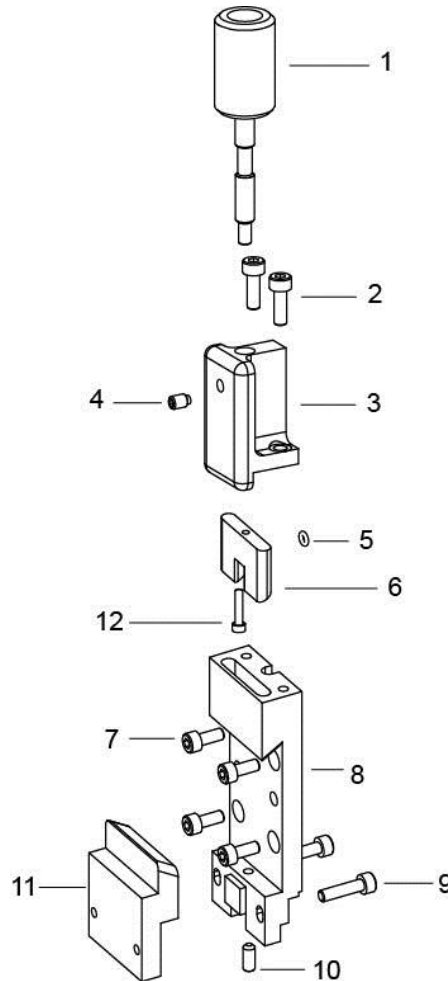

Item	Description	Class I	Qty	Class II	Qty	Class III	Qty
	Top Block Assembly	555538		544156		544156	
1	Manual Knob	537973	1	531754	1	531754	1
2	Soc Hd Cap Screw	130145	2	130467	2	130467	2
3	Top Block	537971	1	531750	1	531750	1
4	Set Screw	516903	1	130304	1	130304	1
	Backplate Assembly	550708		550709		550710	
5	Brake Shoe O-ring	130136	1	130136	1	130136	1
6	Brake Shoe	537972	1	531758	1	531758	1
7	Soc Hd Cap Screw	130184	4	130467	4	250116	4
8	Back Plate	537970	1	531759	1	538153	1
9	Soc Hd Cap Screw	250048	2	544155	2	544155	2
10	Setscrew	130149	1	130470	1	130470	1
11	Gib	537974	1	531749	1	538154	1
12	Soc Hd Cap Screw	n/a	-	598977	1	598977	1

KNIFEHOLDER PARTS

Guide Bar Mount Assembly – Pneumatic Lock

Class I

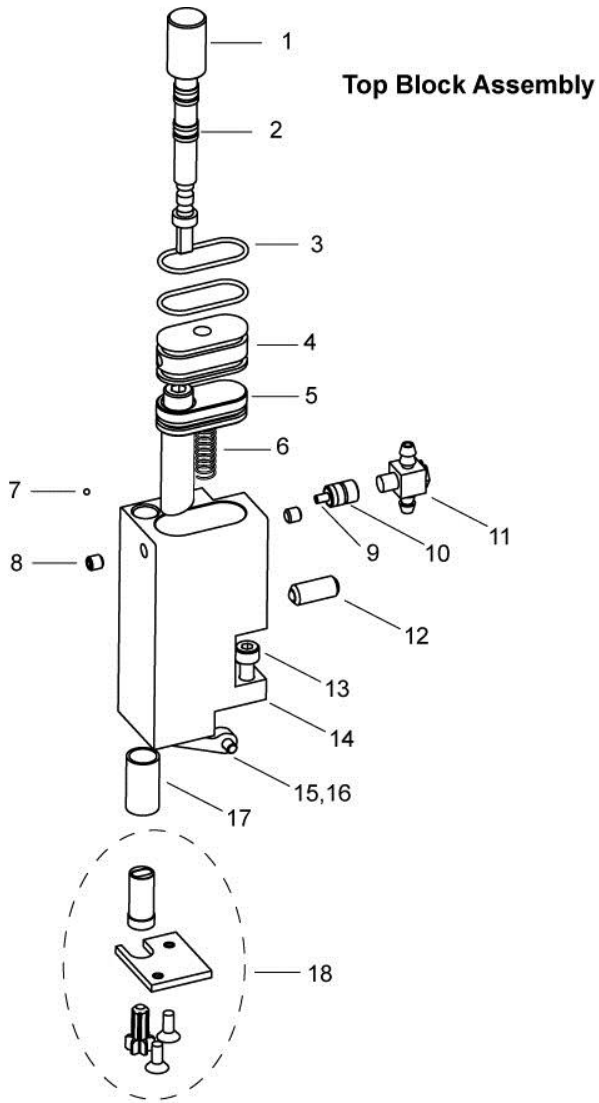

Top Block Assembly

Backplate Assembly

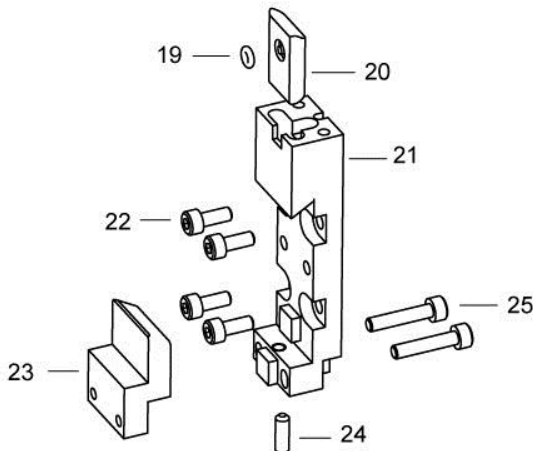

Item	Description	Class I	Qty
	Top Block Assembly	555539	
1	Traverse Knob	550314	1
2	Traverse Knob O-ring	550319	2
3	Piston O-ring	130186	2
4	Piston Cap	550310	1
5	Piston Assembly	550308	1
6	Piston Spring	554681	1
7	Steel Ball	539093	1
8	Setscrew	130147	2
9	Check Valve Insert	573782	1
10	Retainer Housing	573779	1
11	Air Fitting	550731	1
12	Detent Ball	528781	1
13	Soc Hd Cap Screw	130145	2
14	Top Block (Piston Body)	550309	1
15	Lever	550315	1
16	Lever Pin	558991	1
17	Bronze Bushing	557189	1
18	Traverse Gear Assy	550307	1
	Backplate Assembly	550708	
19	Brake Shoe O-ring	130136	1
20	Brake Shoe	537972	1
21	Body Mount	537970	1
22	Soc Hd Cap Screw	130184	2
23	Gib	537974	1
24	Setscrew	132348	1
25	Soc Hd Cap Screw	250048	4

KNIFEHOLDER PARTS

Guide Bar Mount Assembly – Pneumatic Lock

Class II and III

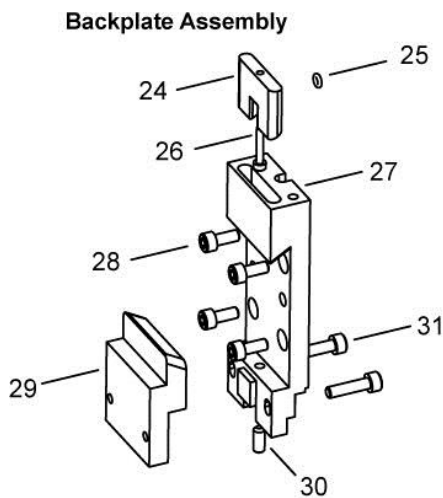
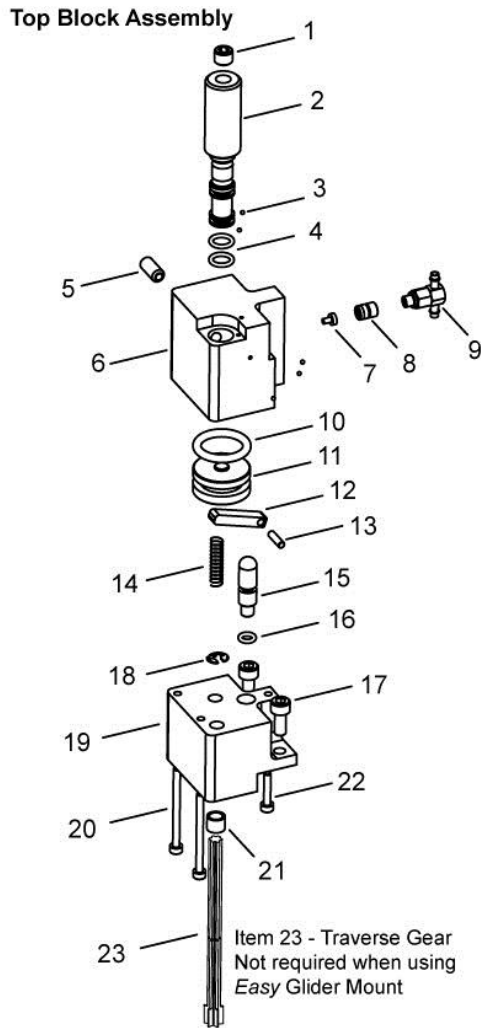

Item	Description	Class II	Qty	Class III	Qty
	Top Block Assembly	550707		550707	
1	Set Screw	132957	1	132957	1
2	Traverse Knob	539088	1	539088	1
3	Steel Ball	539093	5	539093	5
4	Traverse Knob O-ring	554026	2	554026	2
5	Detent Ball	528781	1	528781	1
6	Piston Block	539083	1	539083	1
7	Check Valve Insert	573782	1	573782	1
8	Check Valve Retainer	573779	1	573779	1
9	Hose Barb Tee	251536	1	251536	1
10	Piston O-ring	126479	1	126479	1
11	Piston	131108	1	131108	1
12	Lever	544312	1	544312	1
13	Lever Pin	544308	1	544308	1
14	Compression Spring	554681	1	554681	1
15	Piston Pin	539086	1	539086	1
16	Piston Pin O-ring	126443	1	126443	1
17	Soc Hd Cap Screw	130467	2	130467	2
18	E-ring	549833	1	549833	1
19	Top Block	539084	1	539084	1
20	Soc Hd Cap Screw	549832	2	549832	2
21	Pinion Bushing	564861	1	564861	1
22	Soc Hd Cap Screw	250049	1	250049	1
23*	Traverse Pinion Shaft	539081	1	539081	1
	Backplate Assembly	550709		550710	
24	Brake Shoe	531758	1	531758	1
25	Brake Shoe O-ring	130136	1	130136	1
26	Soc Hd Cap Screw	598977	1	598977	1
27	Body Mount	531759	1	538153	1
28	Soc Hd Cap Screw	130467	4	250116	4
29	Gib	531749	1	538154	1
30	Setscrew	130470	1	130470	1
31	Soc Hd Cap Screw	544155	2	544155	2

* Not required when using *Easy Glider Mount*

KNIFEHOLDER PARTS

Guide Bar Mount Assembly – DuraGlide

Class II and III

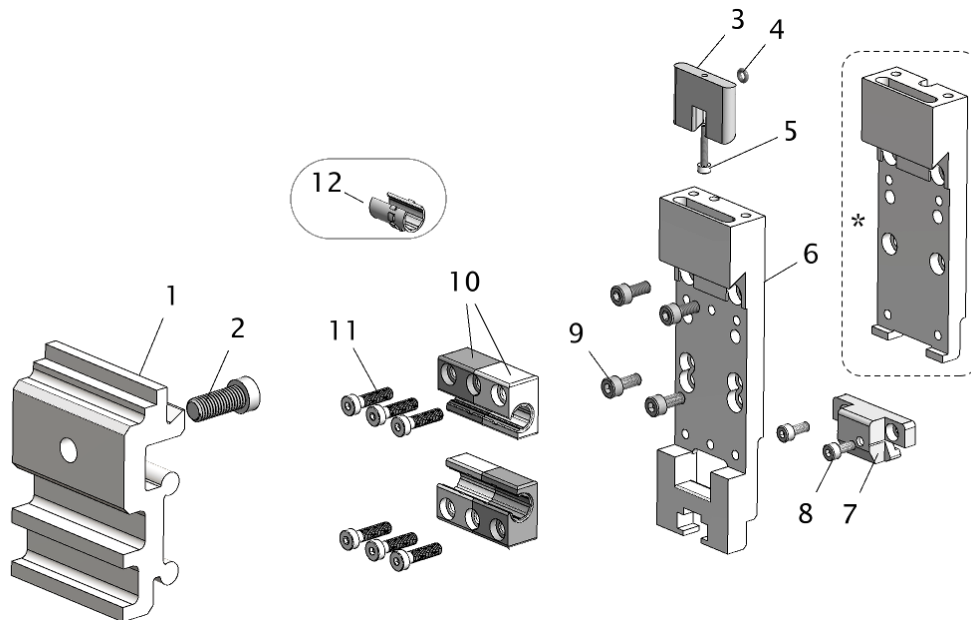

Item	Description	Class II		Class III	
		Part Number	Qty	Part Number	Qty
1	Guide bar extrusion	270020956	1	270020956	1
2	Soc hd, low head 3/8-16	270023032	—	270023032	—
Kit Part Numbers		270022477		270022476	
3	Brake shoe	27L531758	1	27L531758	1
4	O-ring (Parker 2-006)	27L130136	1	27L130136	1
5	Screw, brake shoe adjustment	27L598977	1	27L598977	1
6	Backplate *	270022398	1	270022407	1
7	Dovetail stop	270022465	1	270022470	1
8	Soc hd, low head	M4 x 10mm	27L130184	2	—
		M5 x 12mm	—	—	270022505
9	Soc hd cpscr	M5 x 12mm	27L130467	4	—
		M6 x 12mm	—	—	27L250116
10	Bearing **	270022463	2	270020869	4
		270022462	2		
11	Soc hd, low head M5 x 20mm	270022475	6	270022475	8
12	Bearing liners (replaceable)	270024599	—	270023370	—

* Class II Manual KH only: Uses standard backplate — 360 degree blade guard not available.

** Class II bearing is made up of two part numbers and sold only as a set.

KNIFEHOLDER PARTS

Easy Glider Mount

Use Easy Glider Mounts with standard manual or pneumatic top block assemblies.

Class I

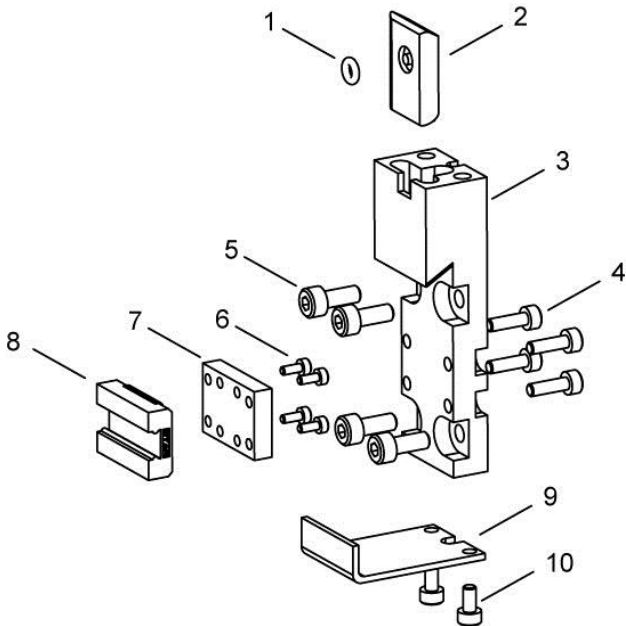

Item	Description	Qty	Part No.
	Back Plate Assembly		689497
1	O-ring	1	130136
2	Brake Shoe	1	537972
3	Backplate	1	662078
4	Soc Hd Cap Screw	4	130163
5	Soc Hd Cap Screw	4	130184
6	Soc Hd Cap Screw	4	662169
7	Bearing Spacer	1	662079
8	Linear Bearing	1	662081
9	Safety Latch	1	662080
10	Soc Hd Cap Screw	2	130247
	<i>Not Shown</i>		
	Guide Bar		661590
	Linear Bearing Rail		662082

Class II and III

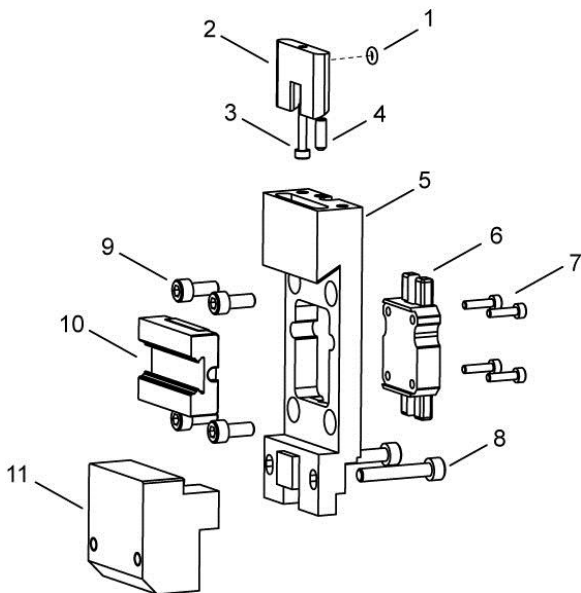

Item	Description	Qty	Class II	Class III
	Back Plate Assembly		615576	618966
1	O-ring	1	130136	130136
2	Brake Shoe	1	531758	531758
3	Soc Hd Cap Scr, Patch Lock	1	598977	598977
4	Set Screw, Nyloc	1	130149	130149
5	Backplate	1	595748	619001
6	Bearing Retainer	1	595703	595703
7	Soc Hd Cap Screw	4	133180	133180
8	Soc Hd Cap Screw	2	132265	132265
9	Soc Hd Cap Screw	4	130467	250116
10	Linear Bearing	1	621879	621879
11	Stop Block	1	595766	619027
	<i>Not Shown</i>			
	Guide Bar		608330	608330
	Linear Bearing Rail		621880	621880

CARTRIDGE TO CONTROL BODY COMPATIBILITY CHART

Performance Series and C Series – Class I, II and III

Tidland e-Knifeholder – Class II and III

NOTE: Use of any other combinations may cause damage to knifeholder or blade cartridge and void warranty.

CLASS I			CONTROL BODY						
			CS Shear*	CS Crush*	PS Shear Automatic	PS Shear Manual	PS Crush	e-KH	
BLADE CARTRIDGE	Description	Pt No	131892	131902	536160	543919	608763 608879	(pending)	
	PS Swing Automatic Shear	547613			✓				
	PS Swing Automatic Shear w/ 360 Degree Blade Guard - Pneumatic	718312			✓				
	PS Swing Manual Shear	551430 596429	✓			✓			
	PS Crush	568412		N/A	✓	✓	✓		
	PS Razor	566769			✓	✓			

CLASS II			CONTROL BODY						
			CS Shear*	CS Crush*	PS Shear Automatic	PS Shear Manual	PS Crush	e-KH	e-KH (2013)
BLADE CARTRIDGE	Description	Pt No	131921	131922	530527	535761	590191 607694	700173	762359
	PS Swing Automatic Shear	524508			✓				
	PS Swing Automatic Shear w/ 360 Degree Blade Guard - Pneumatic	548274			✓				
	PS Swing Manual Shear	569393	✓			✓			
	PS Swing Automatic Shear w/ 360 Degree Blade Guard - Mechanical	766913			✓				
	PS Swing Manual Shear w/ 360 Degree Blade Guard - Mechanical	769816				✓			
	PS Crush	568924		✓	✓	✓	✓		
	e-Knifeholder - w/ 360 blade guard	749142						✓	✓
	e-Knifeholder Swing Cartridge	696317						✓	✓

CLASS III			CONTROL BODY						
			CS Shear*	CS Crush*	PS Shear Automatic	PS Shear Manual	PS Crush CL 2 MOD	e-KH	e-KH (2013)
BLADE CARTRIDGE	Description	Pt No	131923	131923	528812	543324	N/A	708403	762358
	PS Swing Automatic Shear	535264			✓				
	PS Swing Automatic Shear w/ 360 Degree Blade Guard - Pneumatic	548275			✓				
	PS Swing Manual Shear	569394	✓			✓			
	PS Swing Automatic Shear w/ 360 Degree Blade Guard - Mechanical	766915			✓				
	PS Swing Manual Shear w/ 360 Degree Blade Guard - Mechanical	769817				✓			
	PS Swing Automatic Shear High Side Force	650453			✓				
	PS Crush	569508		✓		✓	✓		
	e-Knifeholder - w/ 360 blade guard	753161						✓	✓
	e-Knifeholder Swing Cartridge	700518						✓	✓

* C Series Knifeholders are obsolete and have been discontinued.

BLADE GRINDING AND FINISHING

- Correct blade sharpness is essential for shear and crush slitting operations.
- To reduce chipping and rapid dulling of blades, it is important to remove burred edges.
- Grind the blade edge as smooth as possible to avoid dust formation during the slitting process.
- **Before putting blade into operation**, install the blade and set up the knifeholder at the anvil ring. Manually rotate the blade against the anvil in the reverse direction for a few revolutions. This will help deburr the blade after grinding and provide a smooth slitting edge.

Suggested Blade Grinding Procedure			
Step	Procedure	Wet/Dry	Grit/Hardware
1	If required, grind to remove chips, restore roundness, etc.	Wet	46/60 med/soft
2	Rough grind blade edge	Wet	100 medium
3	Finish grind blade edge	Wet	180 med/hard
4	Deburr	Dry (hand)	Oilstone

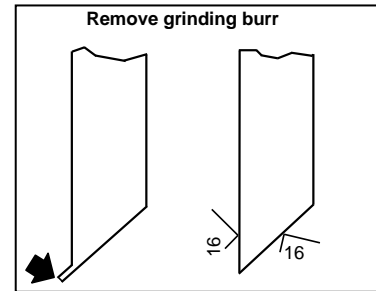

Knife Blades – Shear

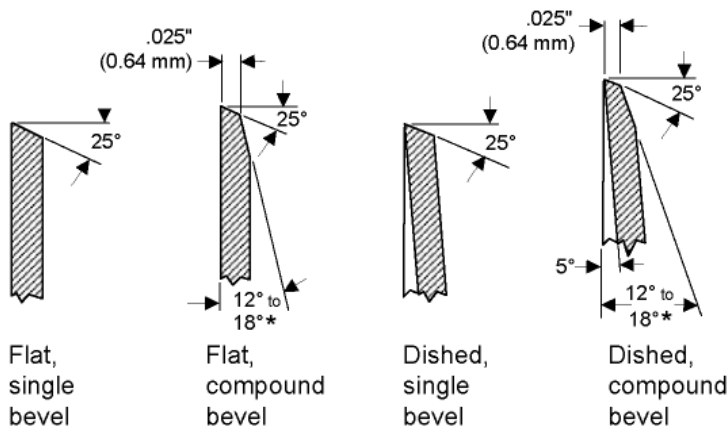

* 12° for blades Ø150 mm and smaller
18° for blades Ø180 mm and larger

Anvil Rings – Shear

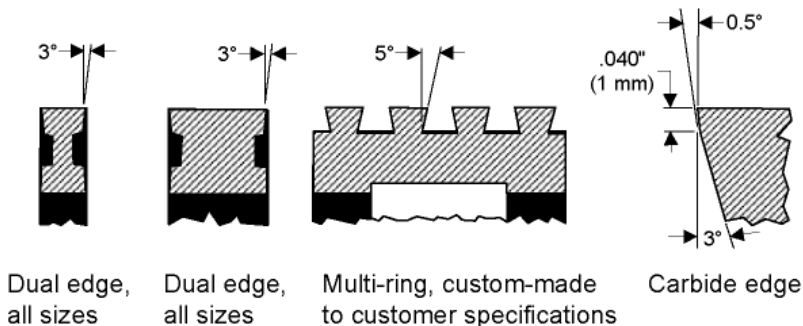

MAXCESS®

AMERICAS
Tel +1.360.834.2345
Fax +1.360.834.5865
sales@maxcessintl.com
www.maxcessintl.com

EUROPE, MIDDLE EAST
AND AFRICA
Tel +49.6195.7002.0
Fax +49.6195.7002.933
sales@maxcess.eu
www.maxcess.eu

CHINA
Tel +86.756.881.9398
Fax +86.756.881.9393
info@maxcessintl.com.cn
www.maxcessintl.com.cn

INDIA
Tel +91.22.27602633
Fax +91.22.27602634
india@maxcessintl.com
www.maxcess.in

JAPAN
Tel +81.43.421.1622
Fax +81.43.421.2895
japan@maxcessintl.com
www.maxcess.jp

KOREA, TAIWAN,
AND SE ASIA
asia@maxcessintl.com
www.maxcess.asia