



Tidland D490 Differential Shaft

User Manual



EN

MI 746508 1 J

CONTENTS

INTRODUCTION	1-1
About these operating instructions	1-1
Product overview	1-2
Model number key	1-2
SAFETY INFORMATION	2-1
Symbols used	2-2
Proper use	2-3
Decommissioning	2-4
ASSEMBLY DIAGRAM AND PARTS LIST	3-1
Shaft components	3-1
CORE SPECIFICATIONS	4-1
General Core Quality	4-1
Core Dimensions	4-1
Table 1. Minimum core widths	4-2
INSTALLATION	5-1
Installing the shaft	5-1
Cartridge orientation	5-2
REWIND applications	5-2
UNWIND applications	5-3
OPERATION	6-1
Air pressure	6-1
Installing the cores	6-1
Winding	6-2
Overspeed	6-2
MAINTENANCE	7-1
Maintenance schedule	7-1
Recommended tools and supplies	7-1
Removing cores from the shaft	7-2
Reinstalling cores	7-2
Spacer gap	7-2
Replacing the air system elements	7-3
Using bulk bladder material	7-3
Preparing the bladder	7-3
Installing the elements	7-4
Cartridges	7-6
TROUBLESHOOTING	8-1
SPECIFICATIONS	9-1
SERVICE AND PARTS	10-1

About these operating instructions

All of the information herein is the exclusive proprietary property of Maxcess International, and is disclosed with the understanding that it will be retained in confidence and will neither be duplicated nor copied in whole or in part nor be used for any purpose other than for which disclosed.

Copyright 2012, 2017, 2020 all rights reserved.

Periodically there will be updates to this manual. The latest version is available on our website or by calling the number on the back page of this publication.

These instructions are designed to help put the external element winding shafts into service and provide important notes for the proper use of the shaft. These instructions are valid for following shaft series: Series D490.

These instructions are important for the machine manufacturer, end user, machine operator and maintenance personnel. Read and understand these instructions before installing and operating the shaft.

The instructions must be read and used by all persons who have the responsibility of installing and maintaining these shafts. These instructions must be retained and incorporated in the technical documentation for the machine or partly completed machinery into which the shaft is installed.

These are the original instructions, written in English.

Theory of operation

The D490 Differential shaft uses cartridges that are designed to spin on the shaft even after web tension causes them to grip and lock the core. Slippage is between the shaft body and cartridges, not the core, so dust is not generated by core wear. Independent cartridges allow for winding multiple cores of different roll widths and roll diameters at the same tension.

Model number key

Shaft series – shaft type – cartridge type

Shaft series D – Differential

Shaft type 490 (air shaft)

Cartridge type B – ball
 S – spring

Available models

D490B

D490S

Safety information

When using this Tidland product, always follow basic safety precautions to reduce the risk of personal injury. Your company's safety instructions and procedures should always be followed. When using this product with any other equipment or machinery, all safety requirements stipulated by that equipment or machinery manufacturer must be followed. Compliance with local, state, and federal safety requirements is your responsibility. No part of these or the following instructions should be construed as conflicting with or nullifying the instructions from other sources. Be familiar with the hazards and safety requirements in your work environment and always work safely.

Read and understand all instructions and shaft design application limits before operation.

- Never use this product for a purpose or in a machine that it was not specifically designed for. See Product Safety Data Sheet (PSDS).
- Do not exceed the operation loads for this shaft as noted on its PSDS, Product Safety Data Sheet.
- Follow all warnings and instructions marked on the product and on the PSDS.
- Do not use fingers or other objects to deflate the shaft; use only the Tidland deflation tool.
- Inspect the shaft for wear and/or other safety and functional deficiencies daily, before each use.
- Wear safety glasses or proper eye protection when inflating or deflating or otherwise operating the air system.
- Do not remove or otherwise alter any setscrews or fastening devices prior to using this product.
- Do not operate this product if any setscrews or fastening devices are missing.
- Do not lift shaft manually if it is beyond your capacity. Loads over 1/3 your body weight may be prohibitive. Consult your company safety policy.
- When lifting a shaft, use proper lifting techniques, keeping back straight and lifting with the legs.

(continued)

- Do not carry or lift this product over wet or slippery surfaces.
- Use appropriate mechanical lifting devices, such as a hoist or shaft puller, for heavier shafts.
- When performing maintenance or repair procedures, do not pressurize the shaft if journal setscrews are loose or missing.
- When performing maintenance procedures, do not pressurize the shaft if the journal is missing.
- All replacement parts used on this product should be made to original Tidland specifications.
- All maintenance and repair procedures performed on this product should be done to Tidland specifications by qualified personnel.

Information about safety instructions

The safety instructions and symbols described in this section are used in these operating instructions. They are used to avoid possible dangers for users and to prevent equipment damage.



SIGNAL WORD

Source of danger and its results
Avoiding dangers

The signal word **DANGER** refers to the danger of death or serious bodily injuries.

The signal word **WARNING** refers to the danger of moderate to severe bodily injuries.

The signal word **CAUTION** refers to the danger of slight to moderate bodily injuries or material damage.

The signal word **NOTICE** refers to the possibility of damage to equipment.

Symbols used

The following safety identification symbols are used in these operating instructions.



WARNING/CAUTION – General danger or important note
Reference to general hazards that may result in bodily injuries or damage to device or material.

**Basic safety
information**

To ensure safe and problem-free installation of the winding shaft, the shaft must be properly transported and stored, professionally installed and placed in operation. Proper operation and maintenance will ensure a long service life of the shaft. Only persons who are acquainted with the installation, commissioning, operation and maintenance of the system and who possess the necessary qualifications for their activities may work on the shaft

Proper use

The Tidland D490 shaft is intended for the purpose of clamping cores or rolls to be used for winding or unwinding web materials (paper, cardboard, plastic film, non-wovens, textiles, and metal foils).

Improper use

Operation outside the technical specifications
Any other use than the proper use shall be deemed inappropriate.

**Basic safety
information**

(continued)

**Installation and commissioning**

WARNING – Danger of falling down or muscle or skeletal injury during installation

The larger design shafts are heavy. Appropriate equipment is to be used and the safety rules of the company must be observed.

**Operation**

WARNING – Danger of entanglement or pinching during operation
Keep hands and loose clothing away from rotating shaft.

**Maintenance and repair**

WARNING – Danger of entanglement or pinching
Maintenance and repair tasks on the shaft must be performed only when the machine has been stopped and has been secured from being turned on again.

WARNING – Danger of bodily injury or damage to hearing.
Do not inflate bladders without the leaves installed.

Decommissioning

The shaft must be disposed of in accordance with all the applicable national, state and local regulations.

Shaft components

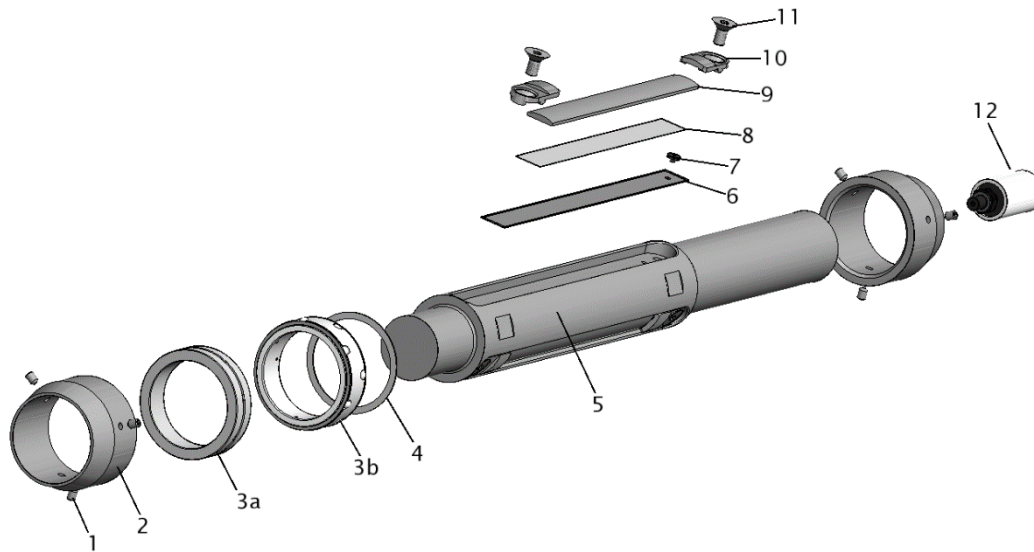

* Recommended spare parts

a/r = as required

Item	Description	Qty	Part No. (N. America)	Part No. (Europe)	
1	Set screw, M6 X 8 mm	3" shaft	6	520013	M194412
	Set screw, M10 x 16 mm	all other shaft sizes	6	525577	M194430
2	Spacer		2	custom	custom
3	Cartridge	item 3a – Spring type	a/r	Note 1, 5	Note 1, 5
		item 3b – Ball type	a/r	Note 1	Note 1
4	Washer (Note 2)	3" shaft	a/r	792914	M372898
		6" shaft	a/r	758835	M386840
5	Shaft body		1	custom	custom
6	Bladder material (Note 3, 4)		a/r	739338	M193425
7	Air fitting		3	562024	M227804
8	Protection strip material (Note 4)		a/r	739340	M245285
9	Friction element material (Note 4)	Kevlar®	a/r	775909	M394448
		Corsid110	a/r	754029	M338602
10	End clamp		6	757450	M390458
11	Flat head cap screw, M8 x 16 mm, zinc plated		6	132937	M127969
12	Rotary union (optional)		1	126231	M186624

Note 1: Cartridge part numbers are dependent upon cartridge width; see chart on page 4-2.

Note 2: For use with ball type cartridge only: use one washer on each side of all cartridges.

Note 3: To order the sealed bladder assembly for your shaft, call Maxcess.
Please have your shaft serial number available.

Note 4: When using bulk material, cut to length using formulas in page 7-3.

Note 5: Replacement springs are available by special order. Call Maxcess for assistance with part numbers.

Core specifications

General core quality

Surface condition of the internal diameter should be smooth for easy installation. Inner edges of cores should be clean and without burrs.

Core dimensions

1. Core inner diameter (I.D.) range must be between
 - 3" shafts: 3.000" – 3.040"
 - 6" shafts: 6.000" – 6.060"
 - 8" shafts: 7.998" – 8.060"
 - 10" shafts: 9.998" – 10.060"
 - 12" shafts: 11.998" – 12.060"
 - a) If core I.D.s are smaller they will be very difficult to load onto shaft. If larger, they will not lock properly.
 - b) Long cores (large slit widths) and cores with I.D. defects (for example, ovality, curvature, etc.) will be more difficult to load if they are at the low end of allowable range.
2. See Table 1 (page 4-2) for minimum core widths.
3. Core width run-out on a single core should be no greater than **0.020"**.
4. Core wall thickness tolerance on a single core should be no greater than **0.010"**. Variance in the core wall thickness will contribute to increased vibration and reduced roll quality.

Table 1. Minimum core widths

CARTRIDGE TYPE	CORE MATERIAL	APPLICATION TYPE	PART NO. (N. AMERICA)	PART NO. (EUROPE)	CARTRIDGE WIDTH	STANDARD MINIMUM CORE WIDTH	ABSOLUTE* MINIMUM CORE WIDTH
3.0 inch shaft diameter							
D490B	ANY	DUPLEX	27L754817	M373598	24 mm [0.95 in]	26 mm [1.0 in]	13 mm [.51 in]
D490B	ANY	DUPLEX / SIMPLEX	27L 754520	M375974	9 mm [0.35 in]	20 mm [.79 in]	11 mm [.43 in]
D490S	FIBER ONLY	DUPLEX / SIMPLEX	27L 754900	M357351	20 mm [0.79 in]	42 mm [0.65 in]	22 mm [.87 in]
D490S	FIBER ONLY	DUPLEX / SIMPLEX	27L 755041	M347869	10 mm [0.39 in]	22 mm [.87 in]	12 mm [.47 in]
D490S	FIBER ONLY	DUPLEX / SIMPLEX	27L 754521	M375975	6 mm [0.24]	14 mm [.55 in]	8 mm [.32]
6.0 inch shaft diameter							
D490B	ANY	DUPLEX	27L 757448	M377935	24 mm [0.95 in]	26 mm [1.0 in]	13 mm [.51 in]
D490S	FIBER ONLY	DUPLEX / SIMPLEX	27L 757449	M377934	25 mm [0.98 in]	52 mm [2.1 in]	27 mm [1.1 in]
D490S	FIBER ONLY	DUPLEX / SIMPLEX	27L 775836	M391870	10 mm [0.39 in]	22 mm [0.87 in]	12 mm [0.47 in]
6.75 inch shaft diameter							
D490S	FIBER ONLY	DUPLEX / SIMPLEX	27L 773507	n/a	25 mm [0.98 in]	52 mm [2.10 in]	27 mm [1.10 in]
8.0 inch shaft diameter							
D490S	FIBER ONLY	DUPLEX / SIMPLEX	27L 768655	M386538	50 mm [1.969 in]	102 mm [4.016 in]	52 mm [2.047 in]
10.0 inch shaft diameter							
D490S	FIBER ONLY	DUPLEX / SIMPLEX	27L 768654	M380981	50 mm [1.969 in]	102 mm [4.016 in]	52 mm [2.047 in]
12.0 inch shaft diameter							
D490S	FIBER ONLY	DUPLEX / SIMPLEX	27L 768653	M386539	50 mm [1.969 in]	102 mm [4.016 in]	52 mm [2.047 in]

* Requires special alignment of cores on cartridges. Call Maxcess for assistance.

Installing the shaft

General



WARNING – Danger of falling down or muscle or skeletal injury during installation

The longer shafts are heavy. Appropriate equipment is to be used and the safety rules of the company must be observed.



Important!

The cartridges are directional and are factory installed relative to customer shaft rotation direction.

Determine shaft rotation, clockwise or counterclockwise.

If the shaft is reinstalled on another machine and rotation direction changes, the cartridges must be removed, reversed and reinstalled. See instructions for your application.

Rewind: page 5-2.

Unwind: page 5-3.

Cartridges installed incorrectly will not grip the cores.

Ball type cartridges must have a washer installed on each side of all cartridges.

Cartridge Types



Ball type cartridge



Spring type cartridge

See illustrations on the following pages to ensure correct installation for your application.

Installing the shaft
(continued)

REWIND applications – cartridge orientation

1	Cartridge load direction
2	Shaft rotation is CLOCKWISE ↻
3	Ball type cartridge – Retainer ring should be visible as shown, facing away from the load direction.
4	Spring type cartridge – End of spring points in direction of shaft rotation

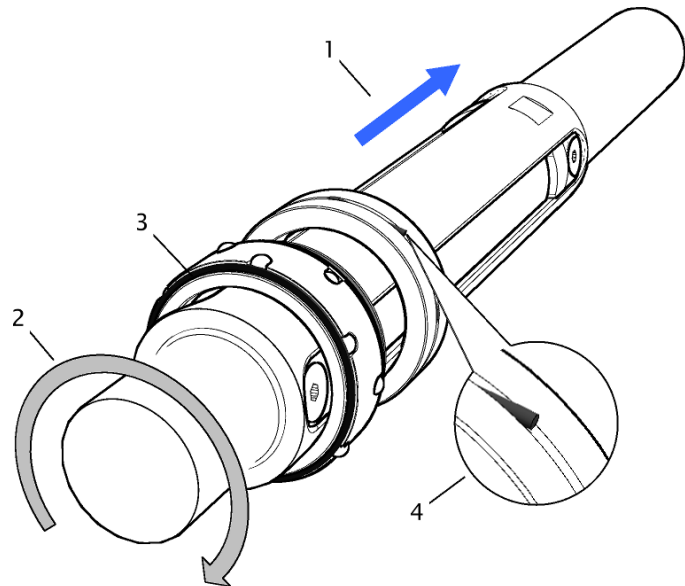

1	Cartridge load direction
2	Shaft rotation is COUNTER CLOCKWISE ↻
3	Ball type cartridge – Flange should be visible as shown; retainer ring faces load direction ➔
4	Spring type cartridge – End of spring points in direction of shaft rotation

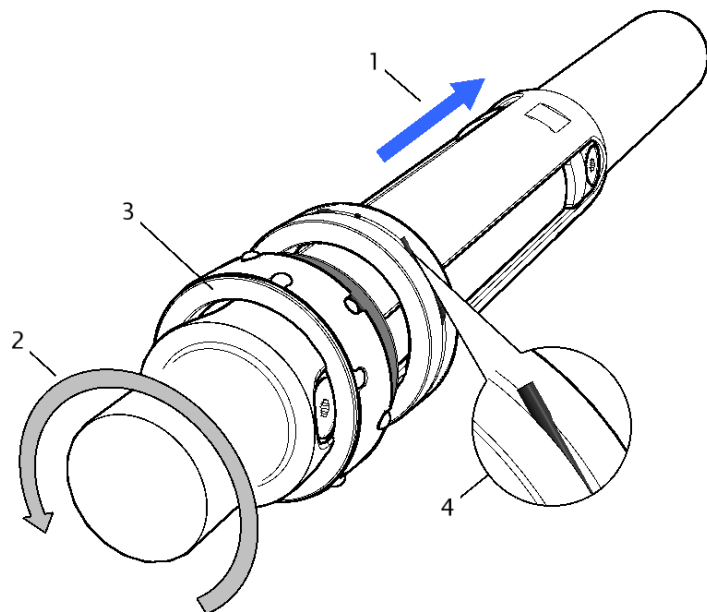

Installing the shaft (continued)

UNWIND applications – cartridge orientation

1	Cartridge load direction
2	Shaft rotation is COUNTER CLOCKWISE ↺
3	Ball type cartridge – Retainer ring should be visible as shown, facing away from the load direction.
4	Spring type cartridge – End of spring points in opposite direction of shaft rotation

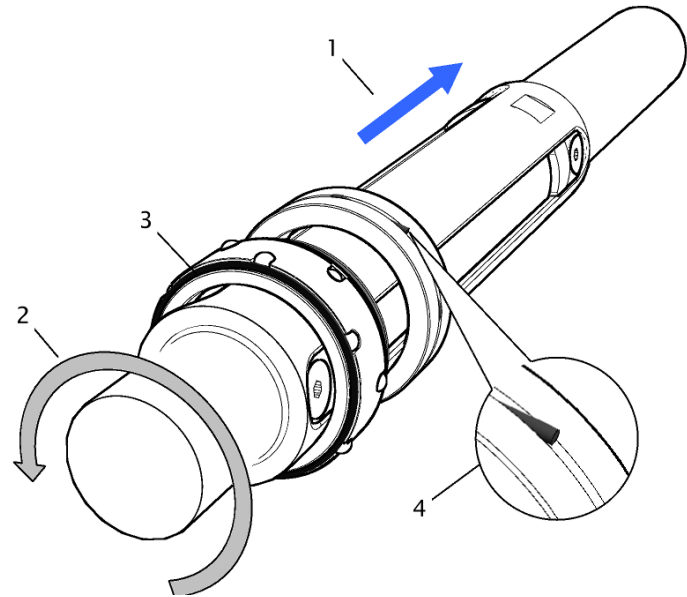

1	Cartridge load direction
2	Shaft rotation is CLOCKWISE ↻
3	Ball type cartridge – Flange should be visible as shown; retainer ring faces load direction. ➡
4	Spring type cartridge – End of spring points in opposite direction of shaft rotation

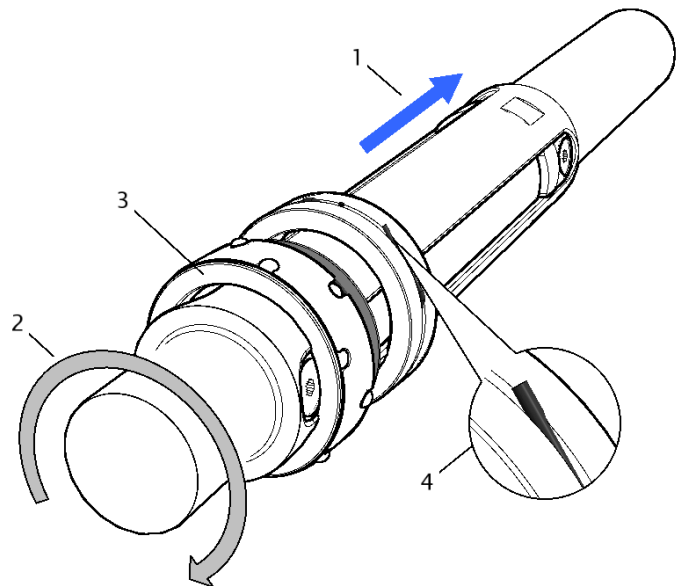

Operation



Use only clean, dry, non-lubricated air.



WARNING - Danger of entanglement or pinching during operation
Keep hands and loose clothing away from rotating shaft.



WARNING - Danger of entanglement or pinching during operation
Keep hands and loose clothing away from rotating shaft.

Air pressure

Shaft operation requires 0.14–5.5 bar [2–80 psi].

Installing the cores

1. Install shaft as required for your machine application.
2. Connect supply air to rotary union (typical).
3. Inflate the shaft to lock the inner race of the cartridges to the shaft — 3.1 bar [45 psi] max.
4. Install the cores.
5. Adjust core positions and attach the web.



To ease installation of cores, twist the core as you slide it on.
For **rewind** operation: twist core in the direction of shaft rotation.
For **unwind** operation: twist core in *opposite* direction of shaft rotation.

Inflating the shaft and winding

The Tidland D490 differential shaft is designed for rewind applications. If you would like to use a D490 for an unwind operation, please contact Maxcess Customer Service.

Begin the winding operation at 0.14–0.3 bar [2–5 psi] for low-tension winding.

During winding, observe the tension controller readout and adjust the applied air pressure as needed.

Overspeed

D490S: To prevent damage to plastic cartridges, do not exceed 30 RPM relative speed between shaft and cartridges.

D490B: To prevent damage to bladder, do not exceed limits illustrated in chart below.

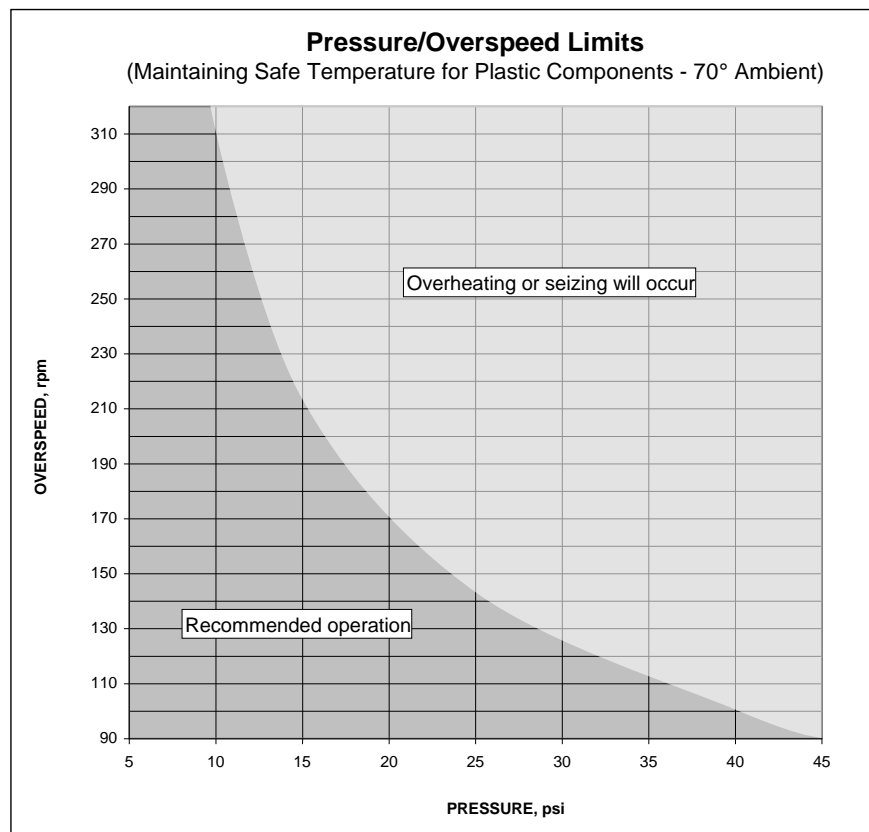

Maintenance schedule

Daily

Keep shaft clean and dry. Use compressed air to remove dust and debris buildup.

Every 30 days

Remove the cores.

Use compressed air to blow out dust and ensure that cartridges turn freely on the shaft.

If cartridges are sticking, disassemble and clean the shaft. Use a mild solution of soap and water to remove residue from shaft.

Inspect cartridges for wear and debris buildup. See page 7-6 for cleaning instructions.

Inspect friction strip for wear. Replace visibly worn material. See page 7-3.

Inspect shaft body for wear. There should be no signs of galling; if scoring or serious wear is detected, call Maxcess Customer Service for assistance.

Before reinstalling cartridges, make sure shaft is clean and free of dust and debris and properly lubricated. See page 7-4.

Recommended tools and supplies

Hex drive wrenches: 3 and 5 mm

Loctite® 243 (or equivalent medium-strength threadlocker)

Mild non-petroleum-based solvent

Ballistol® oil

Hole punch (for bladder air fitting) Tidland Part No. 760668

Hole locator guide (purple) Tidland Part No. 760792

Removing cartridges from the shaft

Before deflating the shaft, remove the cores.

1. Remove the spacer from the shaft. (3 mm hex drive)
2. Install on the shaft an empty core that is long enough to cover all of the cartridges. **Mark the direction of rotation on the core.**
3. Manually rotate the shaft to lock the core onto the cartridges.
4. Deflate the shaft completely.
5. Slide the core off of the shaft with the cartridges secured inside.



To ease removal of cores, twist the core as you slide it off.

For **rewind** operation: twist core in the direction of shaft rotation.

For **unwind** operation: twist core in *opposite* direction of shaft rotation.

Reinstalling cartridges

If reinstalling the cartridges loaded inside an empty core, note the rotation direction marked on the core. If reversing rotation direction, turn the core 180° end to end. Confirm cartridge orientation for your application.

Rewind: page 5-2.

Unwind: page 5-3.

Spacer gap

When reinstalling the spacer at the end of the shaft, you must leave a .030" gap between the last washer and the spacer. Use a shim for better accuracy. Torque set screws to 7 Nm [5.2 ft·lbs].

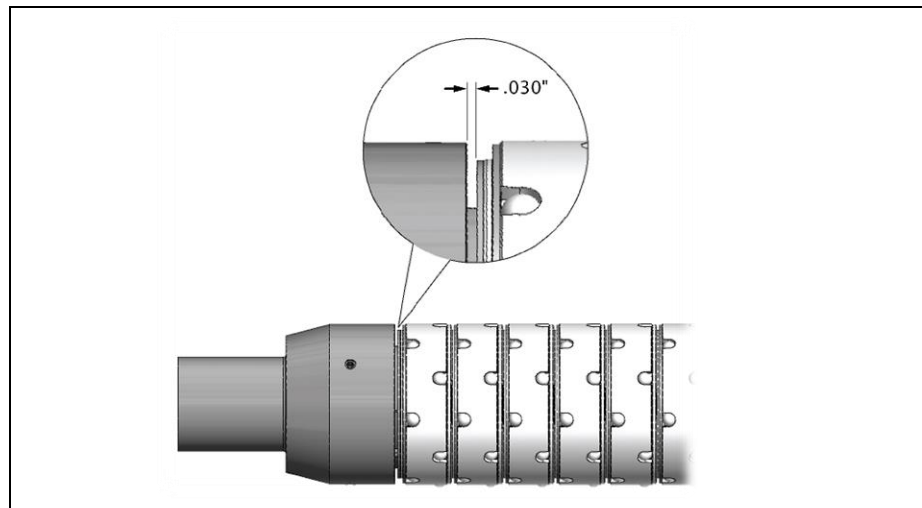

Replacing the air system elements

Tidland D490 shafts are assembled with sealed bladders. If you need to replace the bladder, call Maxcess Customer Service for assistance. Please have your shaft serial number available.

You may also order bulk material for bladders, friction elements and protection strips.

Using bulk materials

Use the following formulas to determine the correct material lengths for your shaft.

Friction element = slot length - 74 mm [2.91"]

Protection strip = slot length - 74 mm [2.91"]

If you use bulk bladder material instead of the sealed bladder assembly:

Bladder length = slot length

Preparing the bladder (bulk material)

1. Cut the bladder to length. Make sure ends are square.
2. Using dimensions illustrated below, locate and punch hole for air fitting. Punch only through one wall of bladder.
3. Insert the air fitting into the bladder.

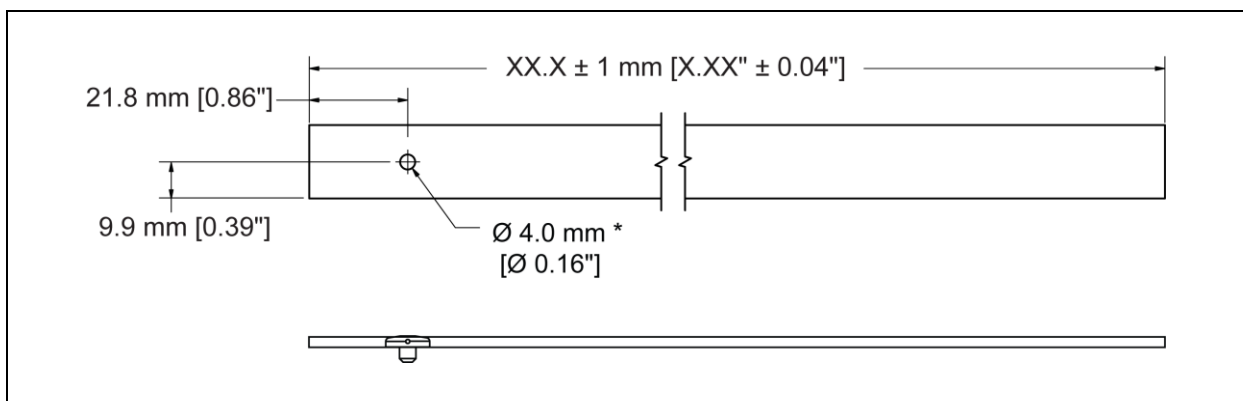

* Punch through one wall only

Installing the elements



Loctite 243

Use on all threads during reassembly. Follow manufacturer's instructions for best results.

Ballistol® oil

High-load applications require proper lubrication to maintain a smooth interface between the shaft body and the cartridges. Apply Ballistol oil liberally to the friction element and the shaft body, and then **wipe off the excess**. Use enough lubrication to prevent galling of the shaft body, but not so much that it is thrown from the shaft during start-up.

Installing the elements

1. Install the bladder with air fitting (sealed or unsealed) in the slot, making sure that the air fitting is seated in the hole.
2. Fold the bladder ends as shown and install the element end clamps and fasteners.
3. Tighten to 17 Nm [12.5 ft-lbs].
4. Install the protection strip and the friction element in the slot on top of the bladder.
5. Lubricate the shaft and friction element with Ballistol oil as described above.

Bladder with **double fold** is folded on top.

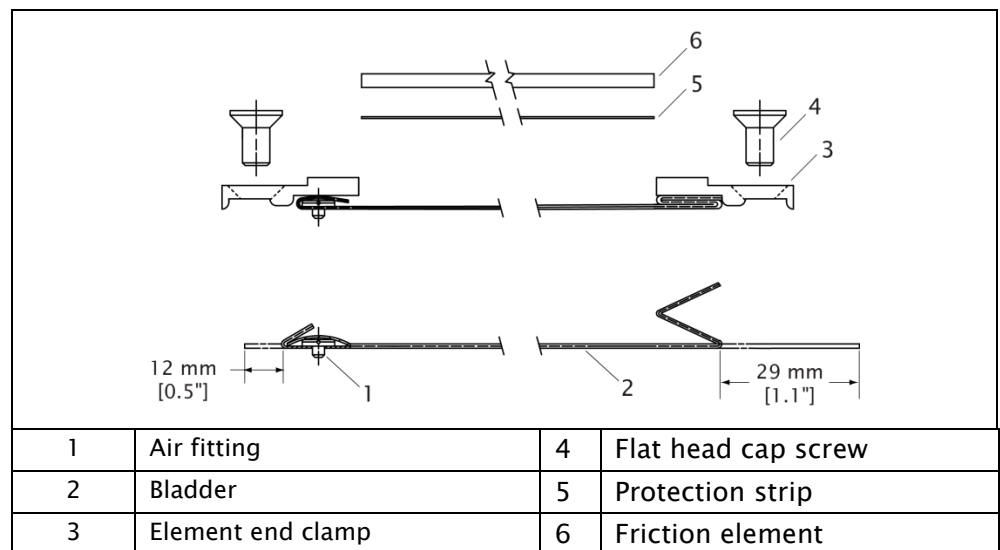

Single fold bladder illustrated on next page.

Installing the elements
continued

Bladder with **single fold** is folded under.

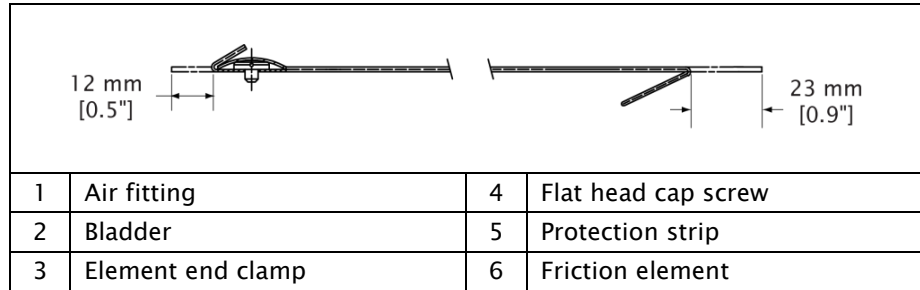

Component part numbers are on page 3-1.



Lubricate the shaft and friction element with Ballistol oil as described on page 7-4.

Cartridges

Spring type



Do not use solvents.

1. Remove the cartridges from the shaft.
2. Remove springs from the cartridges in the **axial** direction to prevent damage to the springs.

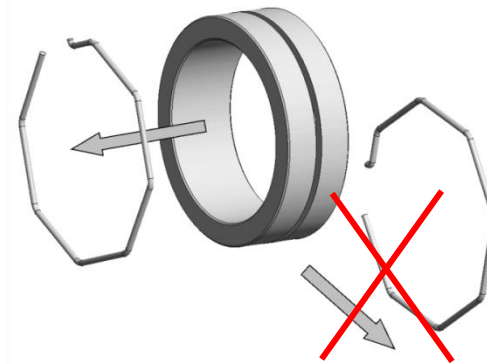

3. Use compressed air to remove dust and debris from cartridge parts.
4. Clean cartridge body with a mild solution of soap and water.



Replacement springs are available by special order.
Call Maxcess for assistance with part numbers.

Ball type

1. During operation, keep cartridges free of dust and debris.
2. If dust build-up on the cartridges prevents actuation, remove the cartridges from the shaft for cleaning.
3. Remove cartridges from shaft; actuate while blowing dust and debris from moving parts.
4. Clean the cartridge body with a light application of non-petroleum-based solvent.
Note: Excessive solvent can cause accumulation of dust and debris. Dry the cartridge body thoroughly before loading cores.
5. Make sure the shaft body is clean, free of dust and debris, and properly lubricated. See page 7-4.
6. Discard and replace the cartridge if it will not actuate.

Problem	Possible Cause	Solution
D490B: Bladder is melting	Excessive overspeed (RPMs)	Reduce overspeed; page 6-2.
D490S: Damage to plastic cartridge	Excessive overspeed (RPMs)	Reduce overspeed; page 6-2.
Shaft leaking air	Bladder not secure under end clamps	Ensure that bladder is pinched under the ridge of the end clamp. Ensure that M8 end clamp screws are tightened to 17 Nm [12.5 ft-lbs].
	Bladder leak	Remove and inspect bladder. Replace if necessary.
Bladder does not inflate properly	Air supply not connected	Ensure good connection to air supply.
	Air fitting in bladder is plugged	Remove air fitting. Blow air through it to remove debris.
Cartridges do not expand fully; cores do not lock	Cartridges installed in the wrong direction.	Check shaft rotation direction and ensure cartridges are installed correctly.
	Cartridge races are worn and chrome balls are loose.	Replace cartridge.
	Dust or contamination build-up in cartridges	Remove cartridges from shaft and manually actuate them while blowing dust and debris from moving parts. Replace cartridge if it will not actuate.
Irregular friction	Dust or contamination build-up in cartridges.	Remove the cartridges and clean contaminants from parts. Clean and lubricate the shaft. See page 7-4.
	Worn or damaged friction element	Remove cartridges and inspect the friction element; replace if worn.
	Missing or worn Teflon washers (ball type cartridges only)	Remove cartridges and inspect for missing washers. Replace washers if missing or worn.
	Insufficient lubrication on shaft body	See page 7-4.

Problem	Possible Cause	Solution
Cartridges do not collapse fully; cores do not unlock	Dust or contamination build-up in cartridges	Remove cartridges from shaft and manually actuate them while blowing dust and debris from moving parts. Replace cartridge if it will not actuate.
Cores slipping on cartridges	Cores are too big	See core size tolerance requirements. If cores are within specifications, contact Maxcess.
Excessive rattling in shaft	Cartridge races are worn and chrome balls are loose.	Replace cartridge.
Chrome balls are falling out of the cartridge	Cartridge races are worn.	Replace cartridge.
Excessive shaft vibration	Shaft imbalance	Contact Maxcess.
Balls or cartridge races are stuck; parts do not move	Dust or contamination build-up in cartridges	Remove cartridges from shaft and manually actuate them while blowing dust and debris from moving parts. Replace cartridge if it will not actuate.
Shaft body or cartridge wear and tear	Dust or contamination build-up on shaft body surface	Remove cartridges and clean the shaft body.
	Center support force is too high.	Reduce roll weight and/or nip force.

Specifications



WARNING – Do not use the devices outside of their rated specifications.

Refer to your Product Safety Data Sheet (PSDS) for your custom shaft specifications.

Operating air pressure	0.14–5.5 bar [2–80 psi]										
Ambient operating temperature	50° C [122° F]										
Core I.D.*	<table border="0"> <tr> <td>3" shafts</td> <td>3.000" – 3.040"</td> </tr> <tr> <td>6" shafts</td> <td>6.000" – 6.060"</td> </tr> <tr> <td>8" shafts</td> <td>7.998" – 8.060"</td> </tr> <tr> <td>10" shafts</td> <td>9.998" – 10.060"</td> </tr> <tr> <td>12" shafts</td> <td>11.998" – 12.060"</td> </tr> </table>	3" shafts	3.000" – 3.040"	6" shafts	6.000" – 6.060"	8" shafts	7.998" – 8.060"	10" shafts	9.998" – 10.060"	12" shafts	11.998" – 12.060"
3" shafts	3.000" – 3.040"										
6" shafts	6.000" – 6.060"										
8" shafts	7.998" – 8.060"										
10" shafts	9.998" – 10.060"										
12" shafts	11.998" – 12.060"										
Core material*											
Ball type cartridge	Fiber or plastic cores										
Spring type cartridge	Fiber cores only										

* See page 4-1 for all core specifications.

:

Service requests and replacement parts

Please have your shaft serial number available when you call.

Maxcess
2305 SE 8th Avenue
Camas WA 98607
1.360.834.2345
1.800.426.1000



AMERICAS
Tel +1.360.834.2345
Fax +1.360.834.5865
sales@maxcessintl.com
www.maxcessintl.com

**EUROPE, MIDDLE EAST
AND AFRICA**
Tel +49.6195.7002.0
Fax +49.6195.7002.933
sales@maxcess.eu
www.maxcess.eu

CHINA
Tel +86.756.881.9398
Fax +86.756.881.9393
info@maxcessintl.com.cn
www.maxcessintl.com.cn

INDIA
Tel +91.22.27602633
Fax +91.22.27602634
india@maxcessintl.com
www.maxcess.in

JAPAN
Tel +81.43.421.1622
Fax +81.43.421.2895
japan@maxcessintl.com
www.maxcess.jp

**KOREA, TAIWAN,
AND SE ASIA**
asia@maxcessintl.com
www.maxcess.asia