

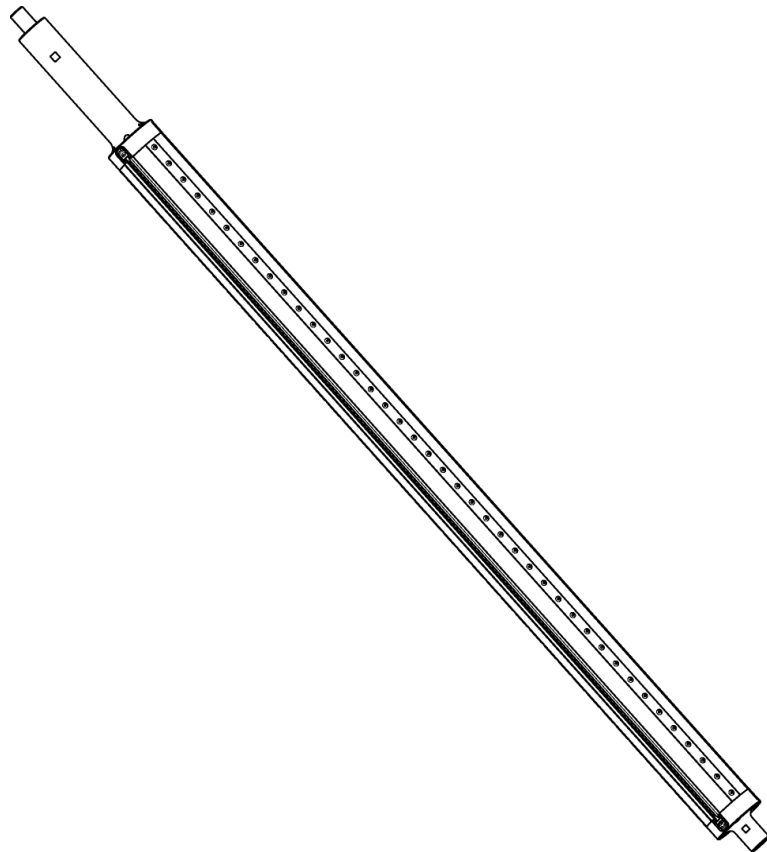

# Tidland Series 950/960 Slitter Shaft

Installation, Operation and Maintenance

---



---

EN

Series 950 GK  
Series 960 GR

## IMPORTANT SAFETY INSTRUCTIONS

When using this Tidland product, basic safety precautions should always be followed to reduce the risk of personal injury. Your company's safety instructions and procedures should always be followed. When using this product with any other equipment or machinery, all safety requirements stipulated by that equipment or machinery manufacturer must be followed. Compliance with local, state, and federal safety requirements is your responsibility. No part of these or the following instructions should be construed as conflicting with or nullifying the instructions from other sources. Be familiar with the hazards and safety requirements in your work environment and always work safely.

1. Read and understand all instructions and shaft design application limits before operation.
2. Never use this product for a purpose or in a machine that it was not specifically designed for. See Product Safety Data Sheet (PSDS), if applicable.
3. Do not exceed the operation loads for this shaft as noted on its PSDS, Product Safety Data Sheet, if applicable.
4. Follow all warnings and instructions marked on the product and on the PSDS, if applicable.
5. Inspect the shaft for wear and/or other safety and functional deficiencies daily, before each use.
6. Wear safety glasses or proper eye protection when inflating or deflating or otherwise operating the air system, if applicable.
7. Do not remove or otherwise alter any setscrews or fastening devices prior to using this product.
8. Do not operate this product if any setscrews or fastening devices are missing.
9. Do not lift shaft manually if it is beyond your capacity. Loads over 1/3 your body weight may be prohibitive. Consult your company safety policy.
10. When lifting a shaft, use proper lifting techniques, keeping back straight and lifting with the legs.
11. Do not carry or lift this product over wet or slippery surfaces.
12. Use appropriate mechanical lifting devices, such as a hoist or shaft puller, for heavier shafts.
13. When performing maintenance or repair procedures, if applicable, do not pressurize the shaft if journal setscrews are loose or missing.
14. When performing maintenance procedures, if applicable, do not pressurize the shaft if the journal is missing.
15. All replacement parts used on this product should be made to original Tidland specifications.
16. All maintenance and repair procedures performed on this product should be done to Tidland specifications by qualified personnel.

## TABLE OF CONTENTS

Caution .....	3
Customer Service .....	3
Recommended Tools .....	3
Shaft Notes.....	5
Install Anvil Rings (Initial Setup).....	5
Lock Anvil Rings in Place.....	5
To Reposition Anvil Rings.....	6
To Remove and Replace Anvil Rings .....	7
Maintenance Schedule.....	8
Daily .....	8
Weekly .....	8
Centering Bars .....	8
Rubber External Elements .....	9
Important Notes (Read First) .....	9
To Remove Rubber Elements .....	9
To Replace Rubber Elements.....	10

## CAUTION

- Wear eye protection when using tools or compressed air.
- Tidland Slitter Shafts are designed to hold anvil rings in place during slitting operations.
- Knife blades and anvil rings are sharp! Avoid injury— always wear stainless steel protective gloves when handling blades.
- Do not operate the shaft when the elements are not inflated.

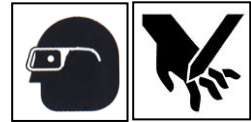

## CUSTOMER SERVICE

1.360.834.2345  
1.800.426.1000

[www.maxcessintl.com](http://www.maxcessintl.com)

## RECOMMENDED TOOLS

- Clean, non-lubricated air supply with regulator: 80-120 psi (5.5-8.3 bar)  
See page 5 for operating air pressure.
- Tidland Inflation Tool (Part No. 128052: for use with fixed valves only)
- Tidland Air Release Tool (Part No. 111630: for use with fixed valves only)
- Tidland Hole Punch and Hole Locator Kit (Part No. 133162)
- Stainless Steel Protective Gloves (Part No. 132084)
- Hex drive wrench kit (Part No. 128363: L-Handle; 1.5, 2, 2.5, 3, 4, and 5 mm)  
(Part No. 132146: T-Handle; 2.5, 3, 4, 5, and 6 mm)
- Wet/dry sandpaper – 600 grit (for removing small scratches and burrs from shaft body)
- *Parker Super O-Lube* O-ring Lubricant (make no substitutions)
- *Loctite*® 222 (or equivalent low-strength threadlocker)
- For more accessories to help with your slitting process, visit [www.maxcessintl.com](http://www.maxcessintl.com).

# ASSEMBLY DIAGRAM AND PARTS LIST

Series 950GK/960GR configurations vary. The shaft shown here features removable journals: it may also be manufactured as a one-piece shaft design.

Call for assistance with part numbers for your shaft. Please have your shaft serial number available when you call.

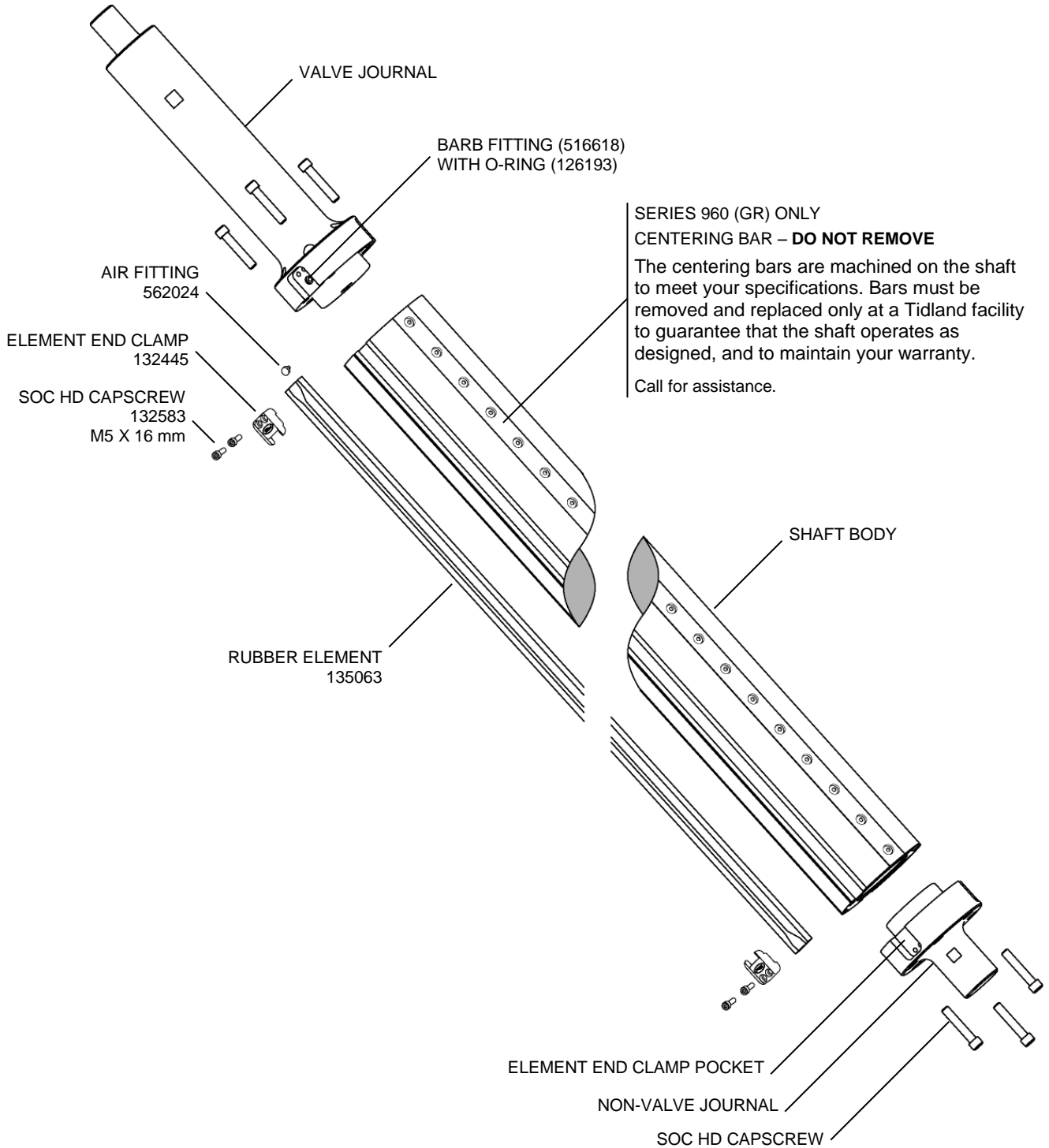

# INSTALLATION

## Shaft Notes

- Tidland Slitter Shafts are designed to hold anvil rings in place during slitting operations.
- Install shaft as required for your specific application: you may need to install anvil rings prior to shaft installation.
- Before each operation, inspect the body and centering bars (Series 960 GR only) for scratches that may prevent the anvil rings from moving freely along the shaft.
- Any large burrs or scratches on the shaft or centering bars must be removed.
  - Use 600 grit wet/dry sandpaper to smooth out the surface.
  - Heavily gouged or deformed centering bars should be replaced. Call for assistance.



### HAND HAZARD

Knife blades and anvil rings are sharp.

Wear protective gloves when working with knife blades and anvil rings. Tidland recommends stainless steel gloves.

## Install Anvil Rings (Initial Setup)

1. Complete your company lockout/tagout procedures to lock out system power.
2. Wear protective gloves when working with knife blades and anvil rings. Tidland recommends stainless steel gloves.
3. Make sure that the shaft is clean and dry and that all screws securing the centering bars (Series 960 GR only) are present and tight. **Do not exceed 45 in-lbs (5.1 Nm) torque. Overtightening will result in deformed centering bars.**
4. Install the anvil rings (and spacers, if applicable), making sure that sharpened edges are toward the slitting sides of the knife blades.

**Note:** Standard Tidland anvil rings are reversible with dual slitting edges: otherwise, install the anvil ring with the sharpened edge toward the slitting side of the knife blade.
5. Reverse lockout/tagout procedure to restore system power.

## Lock Anvil Rings in Place

- To extend the life of the rubber elements, regulate incoming air supply to **55-65 psi (3.8-4.5 bar) for normal operation.**
- If rings are slipping, increase the air pressure as needed in 5 psi increments. Do not exceed 80 psi. 5.5 bar.

See your Tidland Knifeholder Manual for detailed knifeholder setup and operation.



Do not inflate while shaft is rotating.

To Deflate Shaft

- Do not deflate while shaft is rotating.
- Use the Tidland Air Release Tool for fixed valve shafts.  
Do not use finger to release air.



## HAND HAZARD

Knife blades and anvil rings are sharp.

Wear protective gloves when working with knife blades and anvil rings.  
Tidland recommends stainless steel gloves.

## To Reposition Anvil Rings

Follow your company safety procedure.

1. Stop shaft rotation. Deflate the shaft completely.
2. Ensure that the shaft is clean and dry.
3. Move the anvil rings (and spacers, if applicable) to the desired location.
4. To lock anvil rings in place, inflate shaft to 55-65 psi (3.8-4.5 bar). Do not exceed maximum operating air pressure of 80 psi (5.5 bar).
5. See your knifeholder manual for setup at new anvil ring locations.

## To Remove and Replace Anvil Rings

---



If using an air shaft with Tidland e-Knifeholder, do not adjust or remove the ball detent set screws in the anvil rings. These are not fastening screws; they ensure continuity between the shaft and the anvil ring, which is required for proper operation of the e-Knifeholder.

---

### Remove Anvil Rings

1. Stop shaft rotation.
2. Deflate shaft completely.
3. Complete your company lock-out procedures to lock-out system power.
4. Release the air from the slitter shaft using the air valve.
5. Slide the anvil rings along the slitter shaft toward the removable bearing.
6. To help ensure safety and avoid damage to the system, provide alternative support for the slitter shaft before removing the bearing.
7. When slitter shaft is properly supported, remove bearing.
8. Remove anvil rings (and spacers, if applicable) by sliding them off the shaft through the opening in the side frame.
9. Leave the shaft in a supported position.

### Reinstall Anvil Rings

1. Slide the anvil rings (and spacers, if applicable) onto the shaft, making sure that sharpened edges are toward the slitting sides of the knife blades.  
**Note:** Standard Tidland anvil rings are reversible with dual slitting edges: otherwise, install the anvil ring with the sharpened edge toward the slitting side of the knife blade.
2. Reinstall the removable bearing and remove the alternate shaft support.
3. Align knife blades with anvil rings.
4. See your knifeholder manual for repositioning and setup at new anvil ring locations.
5. Reverse your company lock-out procedures to unlock the system power.
6. To lock anvil rings in place, inflate shaft to 55-65 psi (3.8-4.5 bar). Do not exceed maximum operating air pressure of 80 psi (5.5 bar).
7. Resume slitting operation.

## Maintenance Schedule

### Daily

Throughout the operation shift, use compressed air to keep shaft free from dust and debris. Use a mild solvent, rubbing alcohol, to remove any residue. Dry shaft thoroughly.

#### NOTICE

**Petroleum-based products will damage the inflation elements. Do not use.**

### Weekly

Watch for debris buildup along the external elements that might prevent proper expansion of the element. If necessary, remove the elements from the shaft and perform a thorough cleaning (page 9).

## Centering Bars

(Series 960 GR shafts)

The centering bars, made from Acetron<sup>®</sup> GP Acetal (a general purpose copolymer), help ensure accurate positioning for your anvil rings.

Keep the bars and the shaft free from grit and scratches so that the anvil rings slide smoothly along the length of the shaft.

Small burrs, scratches and deformities can be smoothed out using 600 grit wet/dry sandpaper. Large gouges or deformities may require replacement of the centering bars. Call for assistance.

**Do not remove the centering bars.** The centering bars are machined on the shaft to meet your specifications. Bars must be removed and replaced only at a Tidland facility to guarantee that the shaft operates as designed, and to maintain your warranty.



## Rubber External Elements

### Important Notes (Read First)

- The external expansion element material is ethylene propylene diene monomer (EPDM), a synthetic rubber.
- The elements can be replaced without removing the shaft from the machine.
- Do not remove the aluminum T-slot extrusion from shaft when replacing the element.
- Cut elements square across the ends so there is a flush fit at the end clamp.  
**Elements cut at an angle are at risk for leaks.** (Fig. 1)
- Use the Tidland Hole Punch Guide to mark the location of the air fitting hole on the element. (Fig. 2)
- Use the Tidland Hole Punch to punch holes for air fittings in the rubber element. Punch the hole in the **bottom wall only** of the element. (Fig. 3)

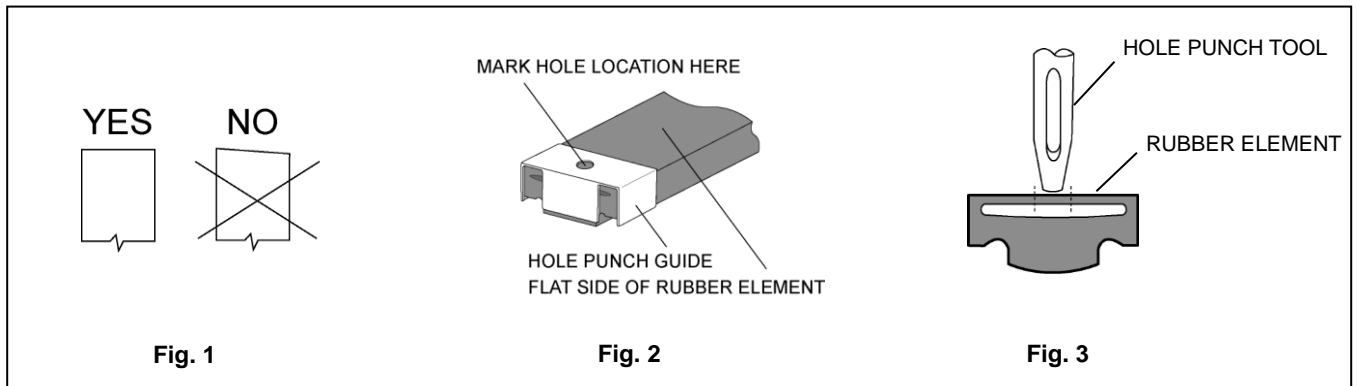

- Make sure that the element end clamps completely cover the ends of the elements.
- To check for leaks after replacing elements, inflate shaft to operating pressure, spray element end clamps with soapy water and check for bubbles.
- There are many configurations for the Tidland Series 950GK/960GR shaft air systems, some of which include the use of a side valve and air hoses. If your shaft is equipped with a non-rotary union (fixed) valve, see page 1.

### To Remove Rubber Elements

1. Release all air from the shaft and disconnect the air supply.
2. Remove the socket head capscrews from the element end clamps and remove the clamps. (4 mm hex drive)
3. At the valve end of the shaft, carefully pry up the rubber element. Ensure that the barb fitting with the o-ring stays in the shaft.
4. Remove the element from the slot. Do not remove the T-slot extrusion from the shaft.
5. Remove the air fitting "head" from the old rubber element.
6. Clean the shaft and slot thoroughly with a mild solvent, such as rubbing alcohol. Dry slot and shaft thoroughly.

#### NOTICE

**Petroleum-based products will damage the inflation elements. Do not use.**

## To Replace Rubber Elements

Bladder material supplied for replacement may be longer than the required finished length. Do not cut to length until instructed.

### Start at the Valve End

1. Square off one end of the element. (Elements cut at an angle are at risk for leaks.)
2. At the squared end of the element, mark the location of the air fitting hole (Fig 4). Center the mark on the flat side of the element 5/16 " (7.93 mm) from the end, or use the recommended hole locator guide. (Page 9, Fig 2)
3. With the Tidland Hole Punch Tool, punch a hole in the **bottom wall only** of the element. (Page 9, Fig 3)
4. Insert air fitting "head" into the hole in the element wall. (Fig. 5)
5. Starting at the valve end of the shaft, push the non-valve end of the element into and through the length of the shaft slot. Use silicone dry lubricant spray to ease installation, if necessary.
6. At the valve end of the shaft, connect the air fitting with the barb fitting in the shaft.
7. Apply a small amount of *Loctite 222* to the end clamp screw threads and install the valve end clamp, securing the element underneath it.
8. Using 4 mm hex wrench, tighten end clamp screws to 55-60 in·lbs (6.21-6.77 Nm).

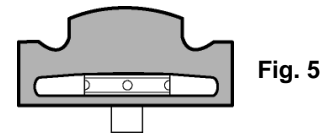
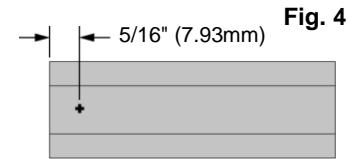

9. At the non-valve end of the shaft, mark the rubber element at a point 3/8" (9.53 mm) from the outside end of the element end clamp pocket. Do not stretch the element. (Fig. 6)
10. Pull the end of the element out of the slot to cut it square across the end at the mark, then push it back into the slot.
11. Apply a small amount of *Loctite 222* to the end clamp screw threads and install the non-valve end clamp, securing the element underneath it.
12. Using 4 mm hex wrench, tighten end clamp screws to 55-60 in· lbs (6.21-6.77 Nm).

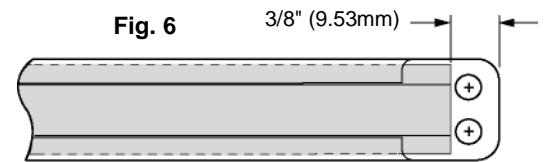

- If the element end clamp does not sit flat in the pocket, the rubber element may be too long. Remove the clamp and trim off a small amount of the element. Reinstall the clamp, ensuring that the element is completely secured underneath.
- To check for leaks after replacing elements, inflate shaft to operating pressure, spray element end clamps with soapy water and check for bubbles.

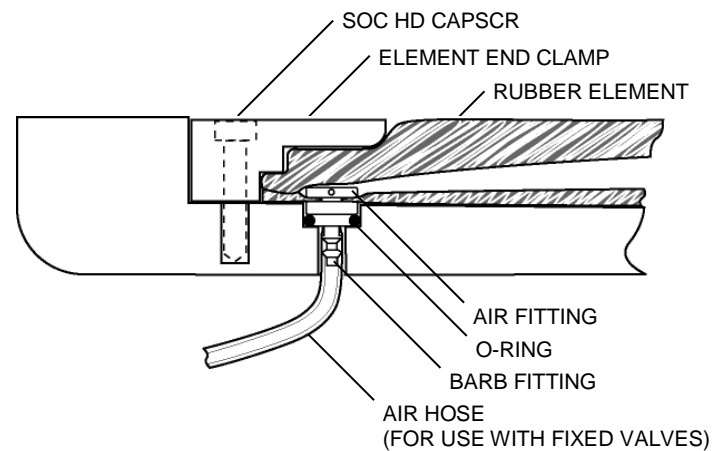

# AIR CIRCUITS

Your Tidland Series 950GK/960GR External Element shaft may be equipped with a fixed valve.

In most cases, the air fitting at the end of each external element (underneath the element clamp) attaches to a hose inside the shaft, which connects to a side or end valve.

- For **single circuit valves**, internal hoses attach to separate barbs on a plug installed either in the journal or on the side of the shaft. Air is delivered through the valve to the plug.
- Some single circuit shafts have no hoses. Air is routed through drilled holes from the valve to the air fittings under the rubber elements.
- **Isolation valves** connect directly to the internal air hoses.
- Maintenance for some air circuit hoses may require removal of shaft journals.
- Hoses may feed out the end of the shaft into the journal or out the side of the shaft, depending upon the type of valve used. Wrap a piece of tape around exposed hoses to prevent them from slipping back inside the shaft body. (Journal removal may be required to retrieve them otherwise.)
- After removing an air fitting, **always** clip off the damaged end of an air hose before reconnecting it to the fitting.

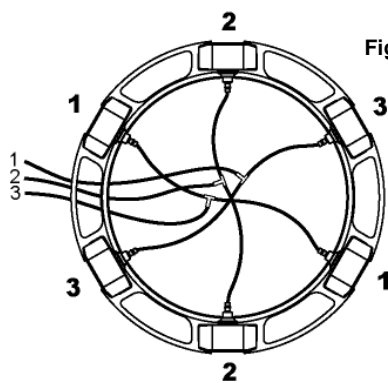

Fig. 7a

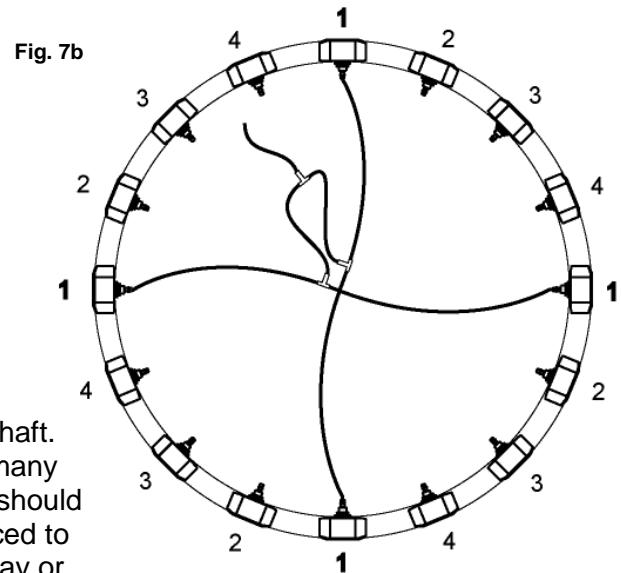

Fig. 7b

**Fig . 7 –** "T-barb" hose connections are made inside the shaft. The number of connections depends upon how many external elements the shaft has. All connections should be made from opposing pairs of hoses and reduced to the minimum number of pairs needed for the 3-way or 4-way valve used, as shown in Fig. 7a and 7b.

**Fig . 8 –** Hoses originating from end clamps in the shaft "head" must feed back into the shaft body before feeding out through the end of the shaft (to prevent being crushed by the journal).

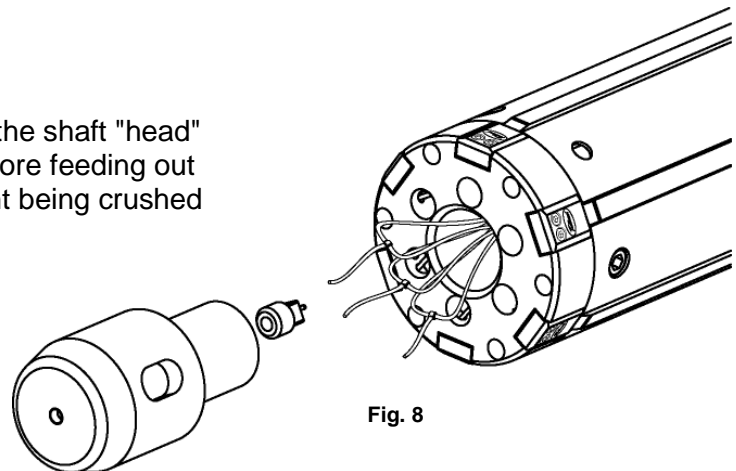

Fig. 8

**Note:** Check air flow through hoses during assembly. Hose kinking can prevent inflation or deflation.

- There are several styles of valves used on Tidland External Element shafts, installed either in the end or the side of the shaft, depending on your application.
- Ensure that the shaft is completely deflated before removing the valve.
- To check for air leaks after reinstalling valves, inflate shaft to operating pressure, spray valve with soapy water and watch for bubbles.

### Non-Isolation Quick Release

Thin wall socket wrench: 7/16", 3/4" (may be required)

1. Use a socket wrench to unscrew the valve from its side or end location in the shaft.
2. Apply thread sealant (according to manufacturer's instructions) and install the valve.

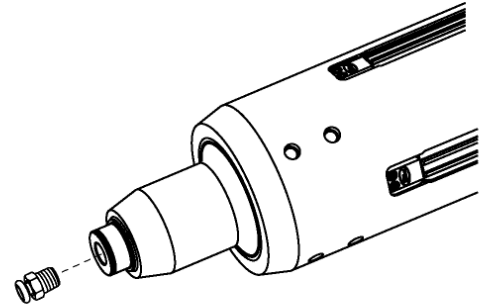

### Isolation Valve (3-way or 4-way)

End or Side Location

1. Remove set screw.
2. Pull valve from end carefully and disconnect air hoses.
3. Cut off damaged ends of hoses.
4. Attach air hoses to new valve.
5. Reinstall valve in shaft.
6. Reinstall setscrew.

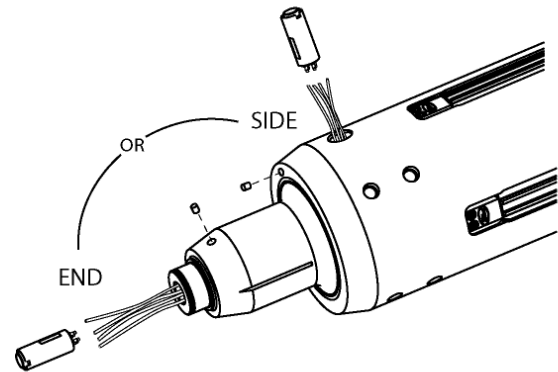

Side Location Bolt-in

1. Remove socket head bolt.
2. Pull valve from end carefully and disconnect air hoses.
3. Cut off damaged ends of hoses.
4. Attach air hoses to new valve.
5. Reinstall valve in shaft.
6. Reinstall socket head bolt.

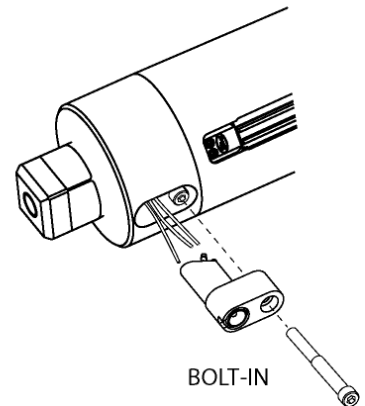

### Before operation:

- Check for proper inflation and deflation.
- If there is a problem, check air hoses for kinks or disconnects. See TROUBLESHOOTING on page 1.

# TROUBLESHOOTING

Problem	Possible Cause	Recommended Solution
Air Leak	Element end clamps not tight	Tighten end clamps at both ends of shaft to 55-60 in· lbs (6.21-6.77 Nm).
	End clamps not centered over element	Ensure that the end clamps completely cover the end of the element. Element must be cut square across its end in order for the end clamp to make contact across the full width of the element.
	Hole for air fitting in element is deformed	Remove end clamp and check the element around the air fitting. If the hole is deformed or the element is torn, replace the element. Use the Tidland Hole Punch Tool for best results when installing air fittings in a new element.
	Air hose connection to the air fitting has failed.	Remove end clamps and confirm that the air fitting is connected to the internal air hose. Check that the fitting is seated correctly in its hole.
	Valve is leaking	Access the valve and confirm that air hoses are attached. If valve is leaking from the center, replace the valve.
External element will not collapse completely	Fiber or dust buildup in element slot is causing scraping along edges of slot	Clean along slot. If necessary, remove and replace external element.
	Cold flow of rubber element	Replace rubber element. Reduce operating air pressure to 55-65 psi (3.8-4.5 bar).
	Kinked internal air hoses	Check hose installation: <ul style="list-style-type: none"> <li>• At air fittings under element end clamps</li> <li>• At valve</li> <li>• In shaft body (may require journal removal)</li> </ul>
Elements difficult to install	Buildup in slot	Clean slot with mild solvent, such as rubbing alcohol, and dry thoroughly. Spray slot and elements with dry silicone lubricant.
External element extrudes out of slot	Element is over-lubricated with dry silicone spray.	Remove element and wipe clean. Reinstall, lubricating only as necessary.

# TROUBLESHOOTING

Problem	Possible Cause	Recommended Solution
Anvil rings do not slide smoothly on the shaft	<p><b>Series 950:</b> Shaft body may be scratched.</p> <hr style="border: 0.5px solid black;"/> <p><b>Series 960GR:</b> Centering bars loose, deformed or damaged</p>	<p>Check shaft body for deep scratches or burrs that may impede movement of anvil rings. Remove scratches with 600 grit wet/dry sandpaper.</p> <hr style="border: 0.5px solid black;"/> <ul style="list-style-type: none"> <li>Ensure that all hardware on the centering bars is tight. (45 in-lbs) (5.08 Nm)</li> <li>Inspect centering bars for scratches and gouges. Remove damage or deformities with 600 grit wet/dry sandpaper.</li> <li>Heavily damaged or deformed bars should be replaced. Contact Maxcess. 1-800-426-1000</li> </ul>
Anvil rings will not fit on shaft	Element end clamps extending beyond shaft O.D.	Inspect element length under clamp. If it is too long, it will push up on clamp. Trim small amount from element and reinstall clamp.
Anvil ring is slipping	Elements not gripping ring	<ul style="list-style-type: none"> <li>Check inflation pressure.</li> <li>Ensure that the external element is expanding completely.</li> <li>Check for leaks.</li> <li>Check for worn elements.</li> <li>Ensure correct ring size.*</li> </ul>
e-Knifeholder not operating correctly	Bad continuity between shaft and anvil ring	<p>Ensure that set screws are present in the anvil rings.</p> <p>Refer to the e-Knifeholder operation manual to check continuity requirements; adjust set screws to achieve continuity.</p> <p>Do not tighten set screws against the shaft.</p>

\* Call for assistance with proper "ring to shaft" fit.

Visit the Repair and Return Center online to review our return policies  
or to submit an electronic Return Material Authorization Request.  
[www.maxcessintl.com/returns](http://www.maxcessintl.com/returns)





---

**AMERICAS**

Tel +1.360.834.2345  
Fax +1.360.834.5865  
sales@maxcessintl.com  
www.maxcessintl.com

**EUROPE, MIDDLE EAST  
AND AFRICA**

Tel +49.6195.7002.0  
Fax +49.6195.7002.933  
sales@maxcess.eu  
www.maxcess.eu

**CHINA**

Tel +86.756.881.9398  
Fax +86.756.881.9393  
info@maxcessintl.com.cn  
www.maxcessintl.com.cn

**INDIA**

Tel +91.22.27602633  
Fax +91.22.27602634  
india@maxcessintl.com  
www.maxcess.in

**JAPAN**

Tel +81.43.421.1622  
Fax +81.43.421.2895  
japan@maxcessintl.com  
www.maxcess.jp

**KOREA, TAIWAN,  
AND SE ASIA**

asia@maxcessintl.com  
www.maxcess.asia