

## INSTRUCTION MANUAL MAGNETIC PARTICLE CLUTCH MODEL C

**CAUTION:** This product contains rotating parts which could cause injury at time of installation. Appropriate protective guards should be installed by the user according to his use of this product.

All of the information herein is the exclusive proprietary property of Maxcess International, and is disclosed with the understanding that it will be retained in confidence and will neither be duplicated nor copied in whole or in part nor be used for any purpose other than for which disclosed.

Copyright 2004, all rights reserved.

Periodically there will be updates to this manual. The latest version is available at [www.magpowr.com](http://www.magpowr.com) or by calling 1-800-MAGPOWR (624-7697).

### THEORY OF OPERATION

The clutch consists of stators, a rotor, drive cylinder, coil, magnetic powder, and bearings which support the drive cylinder and rotor in the stators. The magnetic powder occupies the space between the drive cylinder and rotor, and functions as the adjustable bond or link between them. It is the medium for the transmission of torque.

A current in the coil creates a magnetic field (flux) which passes through the stators, drive cylinder, magnetic powder and rotor. The flux aligns the powder, forming links or bonds between the rotor and drive cylinder. The strength of the bonding action (torque) is proportional to the amount of current in the coil.

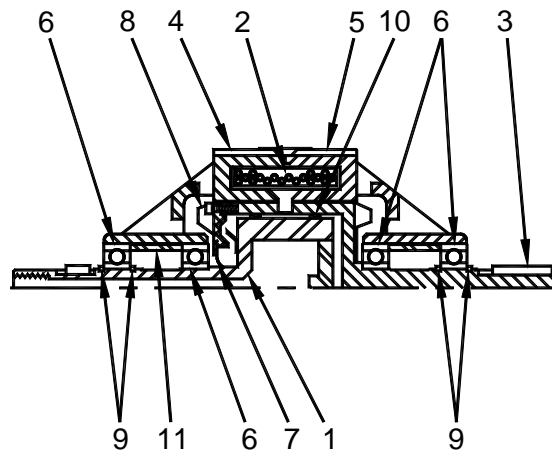

### PARTS LIST

1 Rotor	7 Seal
2 Coil	8 End Bell
3 Drive Cylinder	9 Snap Rings
4 Left Stator	10 Magnetic Powder
5 Right Stator	11 Spacers
6 Bearings (INSIDE BEARINGS ARE HIGH TEMPERATURE BEARINGS, P/N 30A40)	

## INSTALLATION

Prior to installation, check the rotation by hand and observe that it is smooth and free of binding or scraping.

1. Mount the clutch to a base using four suitable bolts. The rotor shaft centerline must be mounted within 30° of the horizontal plane.
2. The outer rotating member is the input, since heat dissipation is related to outer rotating member speed.
3. When using couplings or belts, insure clutch is properly aligned. Flexible couplings must be used for in-line installations.

### Water Cooled Clutch

**GENERAL:** Coupling the output (rotor) to the load may be done using gears, sprocket and chain, or pulley and belt systems. The rotary fitting mounted on the end of the shaft does not allow direct coupling to the load. The clutch must be connected through the power transfer device before the water fitting is attached.

To install a water cooled clutch install the water fitting as follows:

1. Install the washer on the threaded shaft and screw the water fitting into the clutch shaft.
2. Connect the input hose which is the end hose to your water source.
3. Connect the drain hose which is the inside hose (hose nearest clutch housing) to your drain outlet.

To prevent internal condensation, control the input water with an electrically operated solenoid valve. Insure that the input water flow is off when the clutch is off.

## ELECTRICAL CONNECTION

For 24 vdc Devices:

1. Connect the two wires in the clutch junction box to the 24 vdc power source.

For 90 vdc Devices:

1. Connect the 90 vdc power source to the terminals marked 1, 2.
2. Connect the protective bonding circuit to the terminal marked with the P.E. symbol 

## ENVIRONMENTAL SPECIFICATIONS

Temperature Range:

Operating	0°C to 40°C
Storage	-30°C to +80°C
Relative Humidity:	5% to 85%
Pollution Degree:	2 (IEC664-1)
Altitude:	0-2000 meters

## CURRENT RATINGS

**Note:** The clutch coil system has been changed from Class A to Class F. Refer to the nameplate on your unit to determine which insulation class you have. If you have Class F insulation, the nameplate will denote Class F. If you have Class A, there will be no notation on the nameplate.

Model	Supply Voltage, vdc			
	0 - 24		0 - 90	
	Class A	Class F	Class A	Class F
C1			0.18	0.25
C1S7	0.68	0.97		
C3			0.23	0.29
C3S3		1.34		
C10			0.37	0.44
C10S10	1.39	1.67		
C50			0.53	0.86
C50S1	2.12	3.21		
C100			0.61	0.87
C100S4	2.29	3.41		

Maximum current (Amps) at 0°C

Model	Supply Voltage			
	24V		90V	
	Class A	Class F	Class A	Class F
C1			0.13	0.14
C1S7	0.38	0.56		
C3			0.16	0.17
C3S3		0.77		
C10			0.25	0.25
C10S10	1.10	0.96		
C50			0.37	0.49
C50S1	1.39	1.84		
C100			0.41	0.50
C100S4	1.64	1.95		

Rated current (Amps) at Rated Dissipation

## MAINTENANCE

Due to its small number of moving components and its basic design, maintenance of the brake is generally necessary only after extended service. When a problem appears in the system, ensure that all couplings, belts, etc., and the control device are functioning properly. Use the Troubleshooting guide below to determine the cause of the problem. The clutches can be rebuilt with a repair kit which puts it into "as new" condition. A repair kit includes a new powder charge and the appropriate bearings, seals and snap rings generally needed to rebuild the unit.

**NOTE:** When ordering parts not contained in the kit, provide the model number, serial number and parts list item number.

## TROUBLESHOOTING

PROBLEM	POSSIBLE CAUSE	ACTION
Load has slowed down due to insufficient torque transmitted between motor and load	Power supply voltage output low Magnetic powder has deteriorated or is partially lost	Replace or repair power supply Overhaul clutch using repair kit
Load has stopped and clutch rotor is not running with proper voltage	Coil is open	Replace coil
Load operated intermittently with proper voltage	Coil is intermittently open	Replace coil
Clutch is noisy and has some vibration	Clutch bearings are worn	Overhaul clutch using repair kit

## DISASSEMBLY

The following step-by-step instructions pertain to the Model C10 clutch. Due to the similarity of clutches covered in this manual, the step-by-step instructions can be used as a guide in disassembly of all other models. Areas of major difference are covered under notations in the text. When disassembling the clutch refer to the figure while following the text.

1. Remove the junction box cover, nameplate, mounting brackets and retaining screws.
2. Remove the screws retaining the end bell on the drive cylinder.
3. Disassemble left stator and right stator by removing screws.
4. Remove coil.

**NOTE:** The clutch is now disassembled into loose parts plus the rotating group. The following steps outline disassembly of the rotating group.

5. In the following step the powder will be released.
6. Remove screws and empty the powder.

**C1 NOTE:** The end bell in a C1 is retained in the drive cylinder by a press fit. Use a thin-bladed object and carefully remove the end bell.

7. Remove snap ring and shims. Some clutches will not have a shim. If a shim is found, it should be re-installed at the same place during assembly.
8. Use a bearing puller to remove bearing from rotor. Remove snap ring before pulling bearing. Discard seal. (Some units, C100 and C50 have a snap ring behind the second bearing which must be removed before the end bell.)
9. Remove bearings and snap rings from drive cylinder shaft in same way.

## ASSEMBLY

Assembly of the clutch should be performed in a clean area. The clutch components must have all old powder scraped or sanded from OD of rotor and ID of drive cylinder, then cleaned with solvent and be totally free of any grease or oil. Discard all bearings and magnetic powder from disassembled clutch.

1. With bearing seal (rubber side) facing shaft fins, use an arbor press and press bearing into shaft. Press on inner race only. BEARINGS MUST BE HIGH TEMPERATURE (P/N 30A40).
2. Assemble snap ring onto shaft.
3. Install spacer.
4. Press bearing onto shaft with bearing seal facing away from fins. Press on inner race only.
5. Replace snap rings and shims.
6. With seal lip facing away from end bell fins, press seal into end bell until it bottoms.
7. Slide end bell with seal onto rotor shaft. Use a tube such as thin plastic to aid in sliding the seal over the shaft shoulder.
8. Install snap ring if there is a groove next to seal surface.
9. With bearing seal (rubber portion) facing end bell fins, press bearing onto rotor shaft. Press on inner race only.
10. Install snap ring and spacer.
11. Press bearing onto rotor shaft with bearing seal facing away from fins
12. Replace snap ring and shims.
13. Pour magnetic powder into drive cylinder.
14. Place rotor into drive cylinder.

**C1 NOTE:** End bell is a press fit into drive cylinder. Secure with retaining compound; do not get any retaining compound in the powder.

**NOTE:** Drive cylinder and end bell are balanced as an assembly. The components are marked and must be aligned during assembly.

15. Align balance marks on end bell with those on drive cylinder. Replace screws.
16. Assemble right stator over rotor end of rotating group and retain with screw into hole in space.
17. Install coil and assemble left stator over drive end of rotating group.

18. Use a scribe to align holes of spacer with holes of left stator. Install screws and lockwashers.
19. Attach mounting brackets and replace hardware, nameplate and junction box cover.
20. Turn the two shafts by hand in opposite directions while alternately elevating the shaft end 45° to distribute the powder evenly along the inside of the drive cylinder.



MAXCESS INTERNATIONAL COMPANIES



GUIDING · INSPECTION



TENSION CONTROL



SLITTING · WINDING