



INSTRUCTION MANUAL Model TSU Load Cells For Under Pillow Block Applications

All of the information herein is the exclusive proprietary property of Maxcess International, and is disclosed with the understanding that it will be retained in confidence and will neither be duplicated nor copied in whole or in part nor be used for any purpose other than for which disclosed.

Copyright 2004, all rights reserved.

Periodically there will be updates to this manual. The latest version is available at www.magpowr.com or by calling 1-800-MAGPOWR (624-7697).

Introduction

The Model TSU load cell is designed to be mounted under standard inch and metric pillow block bearings. All TSU load cells are pre-drilled and tapped to accept standard inch series pillow block bearings. TSU load cells are compatible with all MAGPOWR Tension Readouts and Controls.

DO NOT HAMMER ON THE TSU LOAD CELL
DO NOT DISASSEMBLE THE LOAD CELL – THERE IS NOTHING INSIDE IT THAT YOU CAN REPAIR

Installation of TSU Load Cells

1. Select a mounting location where the wrap angle of the web does not change.
2. TSU load cells are designed to be mounted under standard, self-aligning pillow block bearings, which support an idler roll shaft. Two TSU load cells should be used to measure tension on one idler roll. Mount the load cells on opposite sides of the machine on a clean and flat surface of the machine frame. The load cells can be mounted in any orientation.
3. OBSERVE THE WRAP ANGLE OF THE WEB AND INSURE THAT THE RESULTANT FORCE DUE TO WEB TENSION IS IN THE “YES” ZONE AS INDICATED ON THE LABEL. If not, turn the load cell around and recheck the direction of the resultant force.

NOTE: If the resultant force is “upward” (away from the load cell), reverse the black (-s) and white (+s) signal leads at the readout or control terminal block.

4. When installing the pillow block bearing, DO NOT EXCEED THE SPECIFIED MAXIMUM BOLT PENETRATION as noted for your specific TSU load cell. If the specified maximum bolt penetration is exceeded, the sensing element will be damaged.
5. If the shaft is exposed to higher temperatures during operation, an expansion type pillow block bearing must be used to accommodate shaft expansion.
6. The sensing roll must be concentric and balanced for high speed operation.
7. Connect the load cell to the MAGPOWR readout or control with shielded cable.

TSU DIMENSIONS

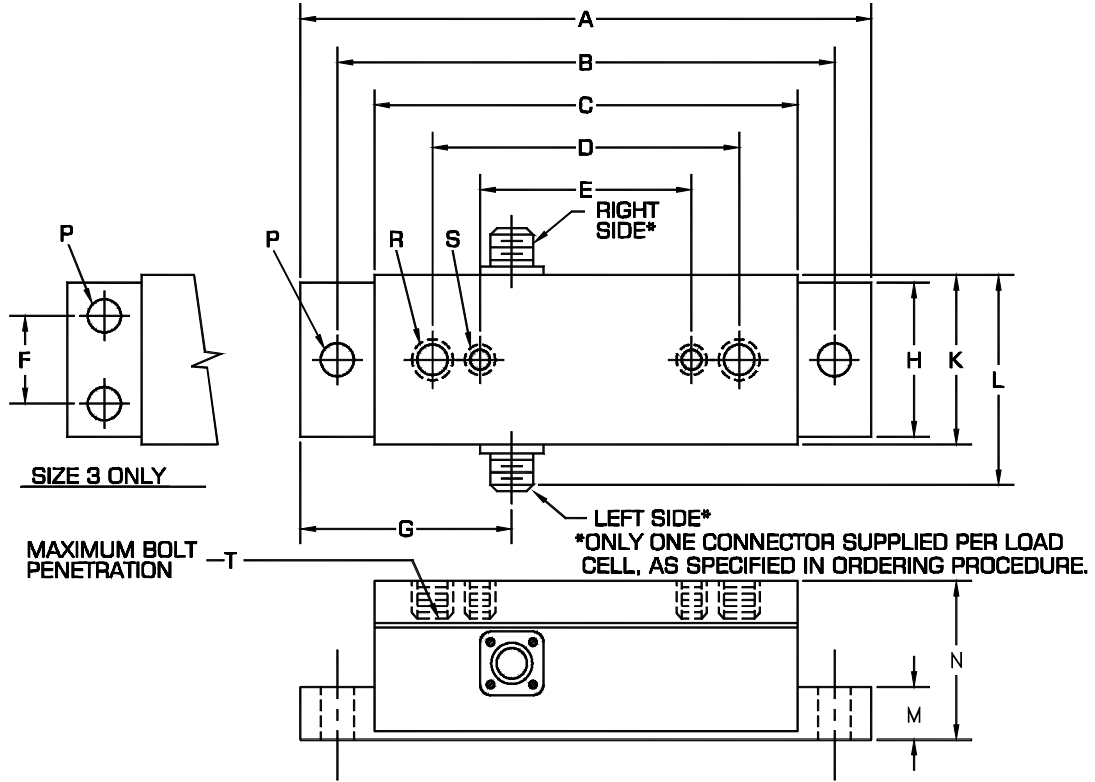

Dimensions

DIMENSIONS (INCHES)

Model	A	B	C	D	E	F	G	H	K	L	M	N	P	R	S	T
1	6.75	5.875	5	3.625	--	--	2.75	1.812	2	2.53	.625	1.87	.406	3/8-16	--	.625
2	9	8	7	5.125	3.625	--	3.75	2.812	3	3.53	.750	2.12	.531	1/2-13	3/8-16	.625
3	13.5	12.25	11	8.375	6.875	2.750	6.25	4.312	4.5	5.03	1	3.18	.531	3/4-10	5/8-11	1

DIMENSIONS (MILLIMETERS)

Model	A	B	C	D	E	F	G	H	K	L	M	N	P	R	S	T
1	171	149.2	127	92.1	--	--	70	46	51	64	16	47	10.3	3/8-16	--	16
2	229	203.2	178	130.2	92.1	--	95	71	76	90	19	54	13.5	1/2"-13	3/8"-16	16
3	343	311.2	279	212.7	174.6	69.8	159	110	114	128	25	81	13.5	3/4"-10	5/8"-11	25

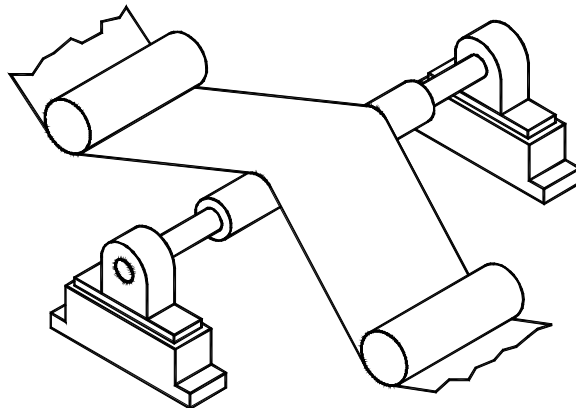

Specifications

Gage Resistance: 350 ohm
 Excitation Voltage: 10 vdc nominal
 Output Signal: 21 mvdc nominal per load cell at full load rating
 Operating Temperature: -30°C to 95°C
 Temperature effect on zero: 0.02% of rating per °C
 Combined non-linearity and hysteresis: 0.5% of full scale maximum
 Repeatability: 0.2% of full scale maximum
 Overload stops: Internal at 105 to 150% of full load rating
 Deflection at full load: All sizes .009 inches (.23 mm)
 Weight: TSU1 = 4.25 lb; TSU2 = 10.5 lb; TSU3 = 36
 Cable Connector: MAGPOWR P/N 12A33-1; ITT Cannon P/N KPT02E-10-6P
 Mating Cable Assembly: MAGPOWR P/N SC-15, 15 ft (4.6 m); SC-20, 20 ft (6.1m) or mating connector P/N 12A36-1
 Climate Class: 3K3 (EN60721)

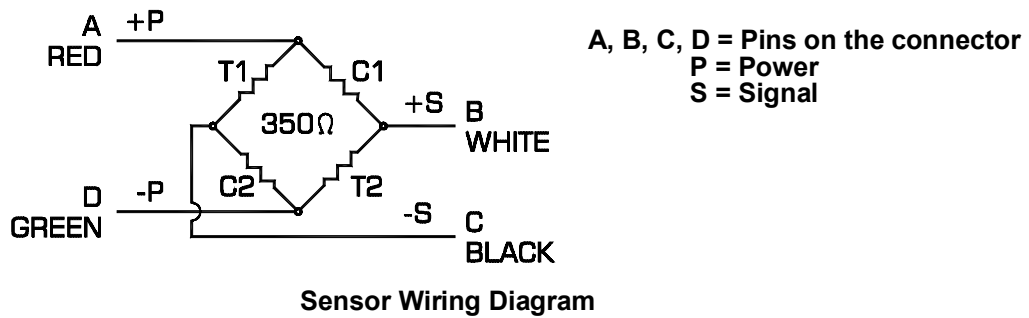

TSU Model Numbers

<u>Model No.</u>	<u>Force Rating</u>	<u>Model No.</u>	<u>Force Rating</u>
TSU1-25	25 lb	TSU3-1000	1000 lb
TSU1-50	50 lb	TSU3-2500	2500 lb
TSU1-150	150 lb	TSU3-5000	5000 lb
TSU2-150	150 lb		
TSU2-500	500 lb		
TSU2-1000	1000 lb		

TSU Ordering Information

The model TSU Web load cells are used in pairs, one on each side of the web. When ordering you must specify one left hand unit and one right hand unit for each sensing roll. Order by model number as shown in the following example:

Example: A requirement for a 1,000 lb capacity load cell of size 2, as shown in the dimension sheet would be specified as TSU2-1000-L for the left side of the sensing roll and as TSU2-1000-R for the right side of the sensing roll.

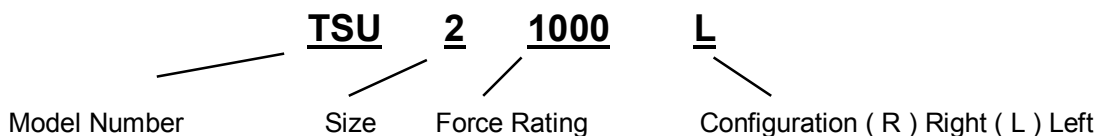

Sizing

To properly size any model TSU load cell select the case (which resembles your application) from the examples shown below. Using your known maximum tension, roll weight, and angles as shown, apply the equation to calculate a "load rating" L. Select a load cell with a load rating greater than that calculated.

EXAMPLE: In case 2 below,
T = 150 lbs., A = 180°, B = 30°, w = 50 lbs.

then $L = 2T \sin(A/2)(\cos B + \sin B) + w/2$
 $L = 2(150)\sin 90^\circ (\cos 30^\circ + \sin 30^\circ) + 25$
 $L = 2(150)(1)(.866 + .500) + 25$
 $L = 435 \text{ lbs.}$
 Select a pair of TSU2-500 load cells

Degrees	Sine	Cosine	Degrees	Sine	Cosine
0	.0000	1.000	50	.7660	.6428
5	.0872	.9962	55	.8192	.5736
10	.1736	.9848	60	.8660	.5000
15	.2588	.9659	65	.9063	.4226
20	.3420	.9397	70	.9397	.3420
25	.4226	.9063	75	.9659	.2588
30	.5000	.8660	80	.9849	.1736
35	.5736	.8192	85	.9962	.0872
40	.6428	.7660	90	1.000	.0000
45	.7071	.7071			

$$L = 2 T \sin(A/2) (\cos B + \sin B) + (W/2)$$

SEE CASES BELOW

L = LOAD CELL RATING
 T = MAXIMUM TENSION
 R = RESULTANT FORCE DUE TO TENSION
 W = ROLL WEIGHT
 A = WRAP ANGLE
 B = ANGLE BETWEEN RESULTANT FORCE DIRECTION AND THE CENTERLINE OF THE LOAD CELL

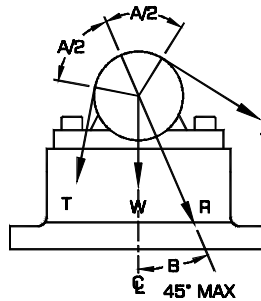

RESULTANT FORCE DIRECTION MUST BE IN QUADRANT 1 OR 2

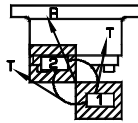

CASE 1
 + FOR RESULTANT IN QUADRANT 1
 - FOR RESULTANT IN QUADRANT 2 (SHOWN)

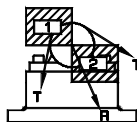

CASE 2
 - FOR RESULTANT IN QUADRANT 1
 + FOR RESULTANT IN QUADRANT 2 (SHOWN)

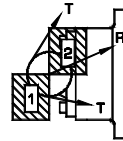

CASE 3
 + FOR RESULTANT IN QUADRANT 1
 - FOR RESULTANT IN QUADRANT 2 (SHOWN)

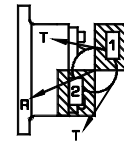

CASE 4
 - FOR RESULTANT IN QUADRANT 1
 + FOR RESULTANT IN QUADRANT 2 (SHOWN)

NOTES:

- Angle B cannot exceed 45°
- The second term (roll weight "W") of the equation must not exceed 50% of the selected load cell rating. If it does exceed 50%, select the next larger load cell rating.
- When the resultant force (R) is pulling in a direction away from the load cell, the signal leads must be reversed at the terminal block of the control.



MAXCESS INTERNATIONAL COMPANIES



GUIDING · INSPECTION



TENSION CONTROL



SLITTING · WINDING