



FIFE DSE-23

Operating Instructions



INTRODUCTION	1-1
About these operating instructions	1-1
Target groups	1-1
Proper usage	1-1
Improper usage	1-2
Operating principle	1-2
Option	1-3
SAFETY INSTRUCTIONS	2-1
Important information	2-1
Information about safety instructions	2-1
Signal words	2-1
Symbols	2-2
Additional markings	2-2
Personnel requirements	2-3
Qualified electrician	2-3
Preventing hazards	2-4
Residual risks	2-4
INSTALLATION	3-1
Transport and storage	3-1
Mounting	3-1
Mounting location	3-1
Dimensions	3-2
Mechanical fastening	3-3
Electrical connection	3-5
OPERATION	4-1
Calibrating the sensor inputs of the web guide controller	4-2
LEDs in normal operation	4-2
MAINTENANCE	5-1
Maintenance	5-1
Decommissioning	5-1
TROUBLESHOOTING	6-1
LED display	6-1
Fault	6-1
TECHNICAL DATA	7-1
General information	7-1
Properties	7-1
Electrical connection	7-2
Pin assignment	7-2
Standards	7-2
SERVICE	8-1
Requests for Service	8-1
Adresses	8-1

1 INTRODUCTION

About these operating instructions

These Operating Instructions describe the installation, operation, commissioning, and maintenance of the DSE-23 sensor and provide important instructions for proper use.

The operating instructions must be carefully stored and must always be available at or near the customer's system during the service life of the sensor.

Translation of the original Operating Instructions:

These Operating Instructions are a translation. The original Operating Instructions were composed in German.

Target groups

These Operating Instructions are directed to both the *system construction master* as well as the *operator* who uses the sensor in production line.



Read operating instructions

The Operating Instructions must be read and used by *all persons* who have the responsibility of installing, commissioning, operating and maintaining the sensor.

Proper usage

The digital infrared sensor DSE-23 is used for non-contact measurement of the lateral offset of a material web being guided in a customer system. The sensor is suitable for

- Web edge guiding and
- Web center guiding for dual application.

The sensor can be used to control both opaque and transparent materials.

A web guide controller must be used with transparent materials to calibrate the sensor to the material. For more information, see the web guide controller operating instructions.

The sensor must only be used in accordance with its intended purpose and in a technically flawless conditions.

The sensor must not be changed or opened.

Improper usage

- Operation outside of the technical specifications is not permitted.
- Operation in areas where there is a danger of explosions is prohibited.
- The sensor may not be used as a support, handle or step.
- Any use other than the designated use is not permitted.

Operating principle

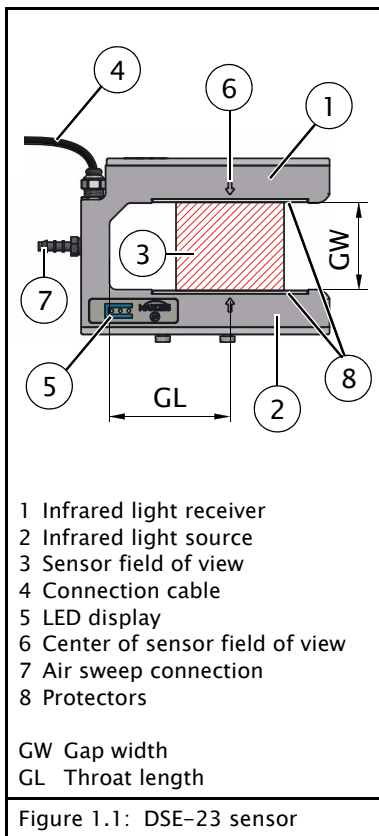

The DSE-23 sensor works with modulated infrared light in the wavelength range of 875 nm, making the sensor relatively insensitive to external sources of light.

The light source generates an infrared light. Depending on how far away the material web is in the sensor's field of view, a part of this light strikes the receiver. Based on this the receiver generates the output signal from which the precise position of the web edge is determined.

The gap width GW and throat length GL are the characteristic dimensions of the sensor.

It is possible to operate the sensor with either a supply voltage of 12V or 24V. The output signal would automatically be switched over in that case.

- Power supply voltage 12V:
The sensor provides an output signal in the range from 0 to 10mA. Thus the sensor can be connected to all Fife web guide controllers.
- Power supply voltage 24V:
The sensor provides an output signal in the range from 4 to 20mA. This can be used to establish a wire-break-proof connection to external devices.

The sensor has a built-in LED display, visible from both sides, and shows directly on the sensor information about the operating status like for instance the existence of the supply voltage, position of the edge of the web inside the field of view or error messages.

The sensor is delivered with an air sweep connection. Depending on the type of dirt contamination, this makes it possible to keep the protectors, which cover transmitter and receiver, free of large pieces of dirt with a continuous or pulsing flow of air.

Option

A digital production data acquisition to Fife D-MAXE controller extends the range of applications for the sensor inside the digital network environment. Additional sensor data can be provided to other hardware equipment if the Fife D-MAXE is linked appropriately to the network.

The protectors can be made of plastic or glass.

2 SAFETY INSTRUCTIONS

Important information

To ensure safe and problem-free operation of the DSE-23 sensor it must be

- properly shipped and stored,
- properly mounted and placed in operation,
- properly used and carefully maintained.

Proper operation and careful maintenance will ensure a long service life for the sensor.

Please note the following:

- The content of these operating instructions
- Any safety instructions that are printed on the unit
- The requirements of the machine manufacturer
- Applicable national, state and local requirements for accident prevention and environmental protection

Information about safety instructions

The safety instructions and symbols described in this section are used in these Operating instructions. They are used to avoid possible dangers for users and to prevent material damage.



SIGNAL WORD

Source of danger and its results.

⇒ Avoiding dangers

Signal words

The signal word **DANGER** indicates an immediate danger of serious injury or death.

The signal word **WARNING** indicates a possible danger which could lead to serious injury or death.

The signal word **CAUTION** refers to a possible danger which could lead to slight to moderate injury.

The signal word **ATTENTION** refers to a possible danger which could lead to material damage.

Symbols

Reference to general hazards that may result in bodily injuries



Refers to danger of injury caused by crushing



Refers to danger of injury caused by cutting



Refers to general hazards that will result in damage to the device or system



Qualified electrician

The electrical components may only be connected and disconnected by a qualified electrician!



Read operating instructions

Follow these operating instructions for proper and safe use.
Keep for future use.

Additional markings

– Bulleted list

• Instructions

1. Instructions which must be processed in the specified order

2. End of the instructions

→ Reference or cross-reference



Note:

Reference to important information.

Personnel requirements

The tasks listed in these operating instructions may only be carried out by appropriately qualified personnel commissioned by the operator. The responsibilities of the personnel for the work on the system must be clearly defined by the operator.

Transport, assembly, maintenance, troubleshooting, disassembly:

- Specialized staff
 - Mechatronics engineer, industrial mechanic, etc.

Electrical connection or disconnection:

- Specialized staff
 - Only by a qualified electrician

Control during operation:

- Specialized staff
 - Machine and system operators, etc.
- Personnel or trainees trained and supervised by the system operator

Repair:

- Specialized staff
 - Service technician of Fife-Tidland GmbH

Qualified electrician



A qualified electrician is a person whose specialist training, knowledge and experience, as well as knowledge of the relevant standards, enable him to assess and perform the work assigned to him and to recognize and avoid possible hazards.

The electrician is specially trained for the field in which he or she works and is familiar with the relevant standards and regulations.

Preventing hazards

- No changes may be made to the sensor.
- Electrical lines must not be subjected to any mechanical loads.
- The parameters specified in Section *Technical Data* must be observed.
- Only accessories and replacement parts that have been approved by Fife Tidland may be used.
- The sensor may not be used as a support, handle or step. There is a danger that the sensor will become damaged (breaking off/snapping), resulting in personal injury.

Residual risks

Installing the product in a machine/system makes it possible to form clamping, squeezing and cutting points.

Despite a safe design and supplementary protective measures, residual risks may remain for the machine/system in which the product is installed. These risks must be recorded in a risk assessment by the machine/system builder and taken into consideration in the operating instructions.

3 INSTALLATION

Transport and storage

- The sensor and/or the unit on which the sensor is mounted must be secured against slipping during transport
- The sensor must be stored in a cool, clean, and dry place.
→ *Ambient conditions, page 7-1*
- The sensor must not be stored in the vicinity of powerful magnetic fields. The electronic components of the sensor may be damaged.

Mounting



WARNING

- ⇒ If a sensor is damaged, it must not be installed or placed in operation.
 - ⇒ All assembly tasks on the sensor must only be performed when there is no electrical power in the system.
 - ⇒ Assembly tasks and mechanical settings must only be performed when the machine has been stopped and secured from being turned on again.
-

Mounting location

- Protection Class: IP54
IP64 optional
- Operating temperature: 5°C ... 60°C
- Relative humidity: max. 85%, non-condensing
- Operating altitude above sea level: maximum 5000m
- Protected from vibrations
- Do not place close to strong magnetic fields:
The electronic components may be damaged.
- Do not place close to strong electrostatic fields:
The electronic components may be damaged.
- Not in places where there is a risk of explosions.

Dimensions

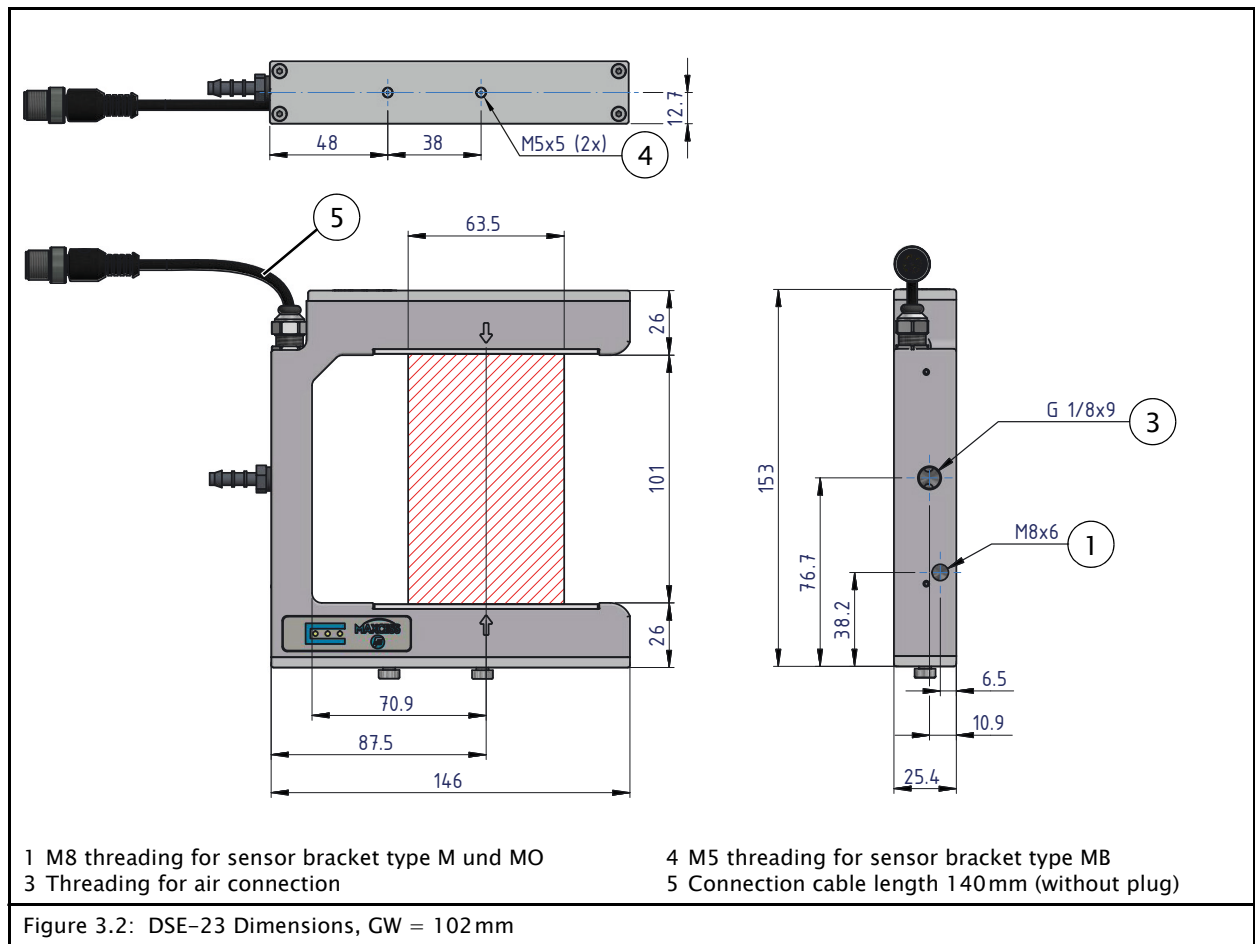
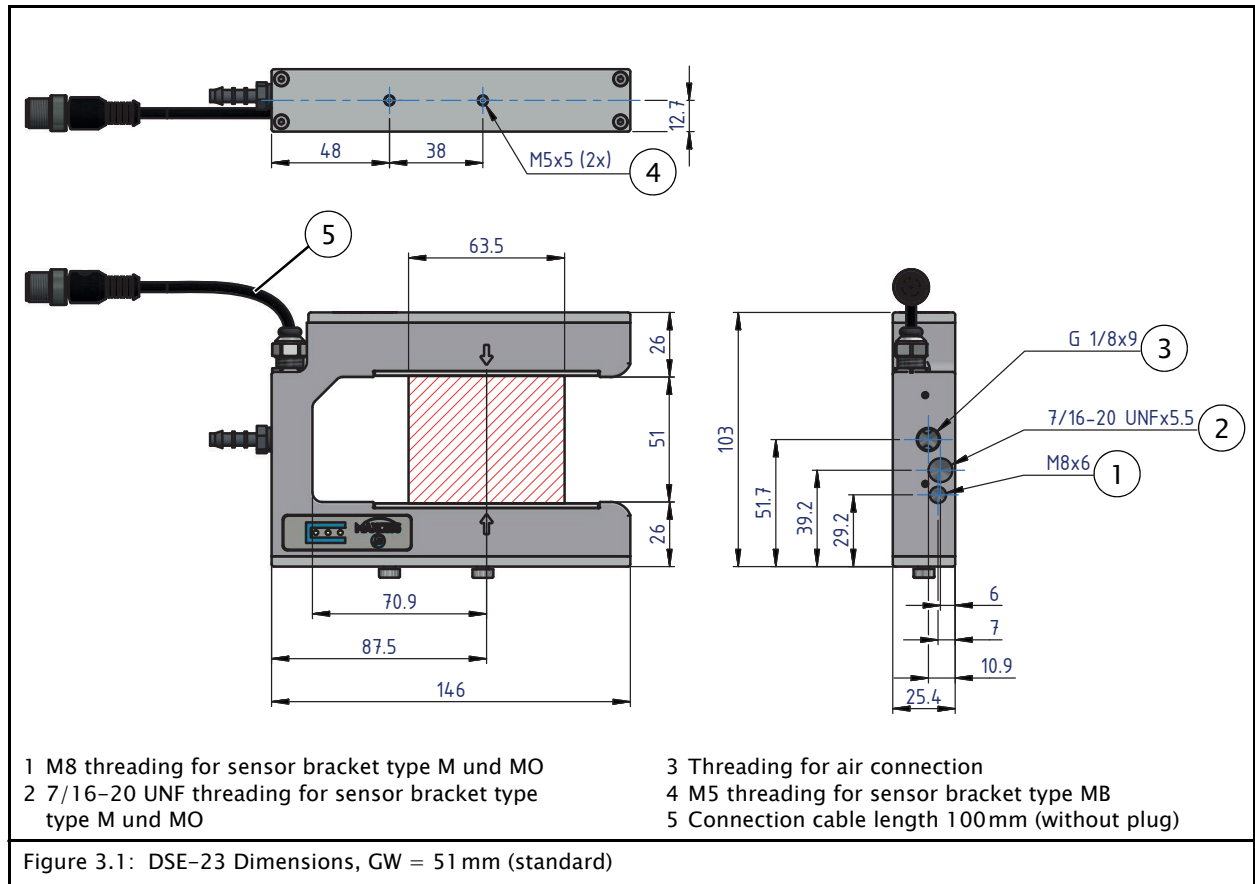

Mechanical fastening

Drill holes are available on the housing for fastening the sensor in place. A large variety of assembly options are possible in connection with the various sensor mountings.

**ATTENTION**

- ⇒ Tighten the M5 fastening screws to a max. torque of 3Nm.
- ⇒ Tighten the M8 fastening screws to a max. torque of 9Nm.
- ⇒ Tighten the 7/16-20 UNF fastening screws to a max. torque of 12Nm.

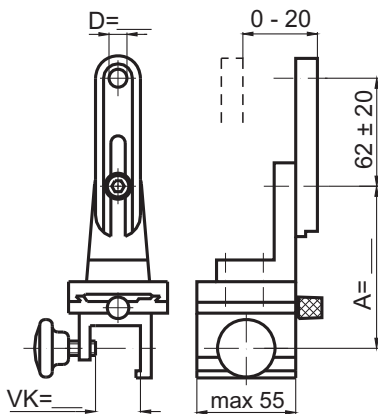
**Sensor bracket type M***

Type	A	VK	D
M-20/8	86	20	8
M-20/7/16	86	20	12
M-25/8	88	25	8
M-25/7/16	88	25	12

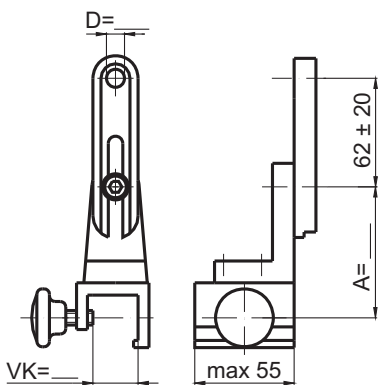
**Sensor bracket type MO***

Type	A	VK	D
MO-20/8	69	20	8
MO-20/7/16	69	20	12
MO-25/8	71	25	8
MO-25/7/16	71	25	12

Sensor bracket type MB*

Sensor bracket	Square bar		A	B	C
	x	max. length			
MB-20	20	1600	15,5	39	15
MB-25	25	2200	18,5	41,5	18,5

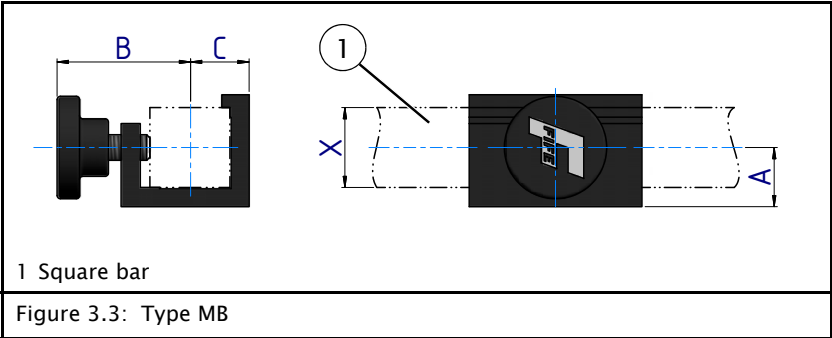

* Other dimensions are possible upon request.

Electrical connection



ATTENTION

The sensor could be damaged.

- ⇒ The safe function of the sensor and the system is only guaranteed if it is properly installed.
 - ⇒ Electrical connections should always be made or disconnected on the sensor while there is no electrical power in the system.
 - ⇒ When attaching the connector with the jack on the sensor, pay close attention to the guide and groove! The connector and jack must not be connected with incorrect orientation or by force, as this will destroy the sensor.
 - ⇒ Electrical lines must not be subjected to any mechanical loads.
-

- The sensor must be connected to the web guide controller according to the system diagram in the system documentation.



only for sensor cables with open wire ends

Personnel: Qualified electrician

⇒ The sensor may only be connected electrically by a qualified electrician.

- The power supply voltage must be externally fused.
→ *Power supply, page 7-2*
 - The external 12V/24V DC voltage must be generated and supplied in accordance with the criteria for protective extra-low voltage (PELV).
 - The negative potential must be connected to ground.
 - The sensor housing must be grounded via the cable screen.
- see also the drawing for the sensor cable in the system documentation

4 OPERATION



WARNING

Danger of injury by crushing

⇒ Do not place your hands on or near moving parts (rollers, material web, etc.) during operation.



Danger of injury due to cutting on the edge of the material web

⇒ Do not place your hands on the edge of the (moving) material web during operation.



ATTENTION

The sensor could become unusable during the operation by damages.

⇒ The sensor must not be placed in operation unless it has been securely mounted.

⇒ Depending on the material of the guided web, if the web rubs on the protectors of the sensor, the protectors may become damaged. If a protector is scratched and/or unclear, the material web can no longer be reliably guided.

⇒ Depending on the material of the web that is being guided, it is possible that the web edge could grind against the inside of the sensor fork, resulting in notches and incisions on the sensor.

Calibrating the sensor inputs of the web guide controller

All settings required for operating the sensor are performed with the web guide controller.

→ Information on this topic is available in the Operating Instructions for the web guide controller.

Before the sensor is used for working with transparent material, the sensor must always be calibrated to the contrast with the web guide controller.

LEDs in normal operation

- Field of view completely uncovered:
The outer LED flickers. The two inner LEDs are off.
→ Example A
- Field of view partially or completely covered by the material:
The LED on which the edge of the material web is located flickers. The LED(s) of the covered area(s) is/are lit.
→ Example B

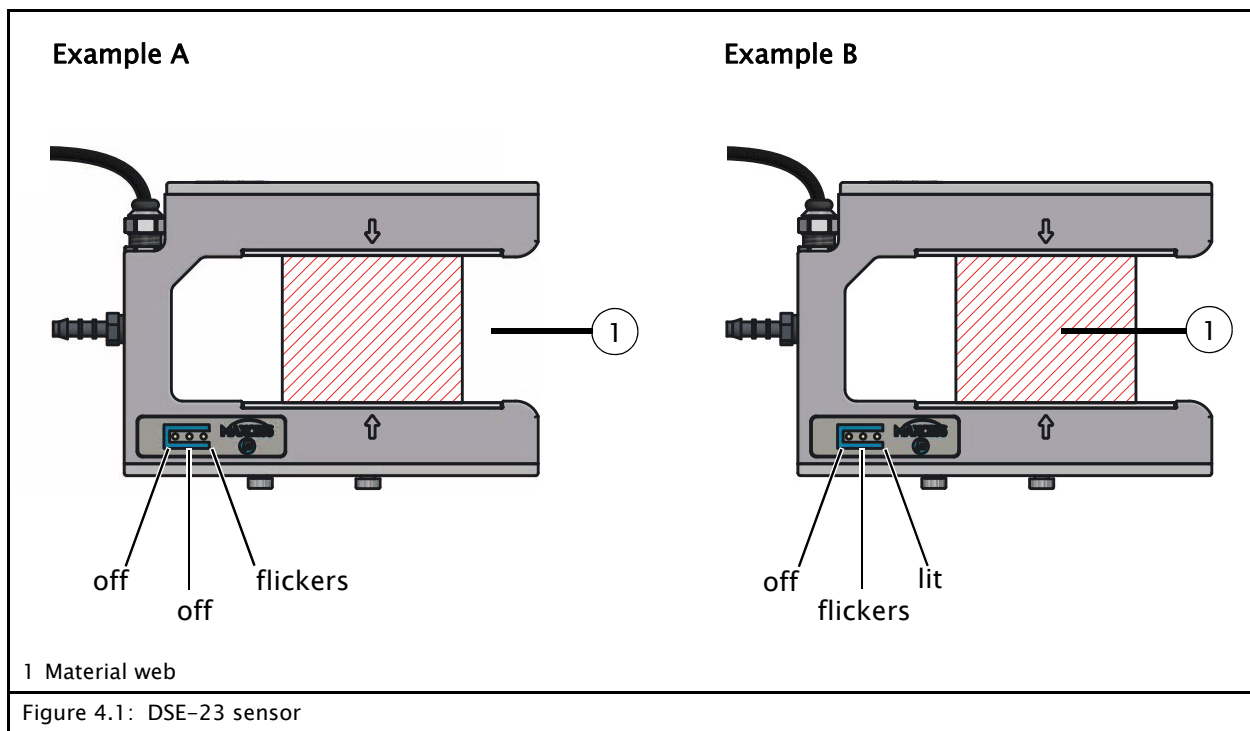

5 MAINTENANCE



WARNING:

Danger of injury by crushing.

⇒ Maintenance work must only be performed on the sensor when the power is turned off and the machine is stopped and protected against being turned on again.

Maintenance

The protectors should be cleaned of ambient dust and dirt at regular intervals using a neutral synthetic cleaning agent and a soft cloth. When selecting synthetic cleaning agents, note chemical resistance.

→ page [7-1](#)

No additional maintenance tasks are required for the sensor.

Decommissioning



1. Turn off the electrical power to the system.
2. Disconnect the signal cable from the sensor.

only for sensor cables with open wire ends

Personnel: Qualified electrician

⇒ The sensor may only be disconnected electrically by a qualified electrician.

3. Unscrew the sensor from its bracket.
4. Store the sensor in a cool, clean and dry place.
→ [Ambient conditions, page 7-1](#)

OR

Dispose of the sensor according to your national requirements.

6 TROUBLESHOOTING

LED display

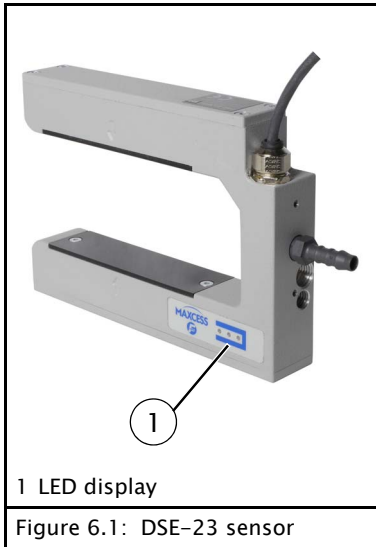

The sensor displays information about the operation state when the LEDs are lit or flashing. The information is divided into groups as follows:

Normal operation:

The output signal of the sensor is displayed. The LEDs flicker/ light up depending on the position of the material web within the sensor field of view.

Error message:

Error n = 1 .. 3:

The output signal of the sensor (10s long) and the flashing pattern of an error are displayed alternately. An error is displayed until it has been corrected. It is still possible to use the sensor.

Error n = 4 .. 7:

Only the blinking pattern of an error is displayed. The sensor is no longer supplying a valid output signal.

Fault

In the event of an error, the LEDs flash with a certain pattern: flash n times for 0.5s on – 0.5s off, followed by 1s pause. The number of flashing pulses between two pauses encodes the error number "n".

„n“	Fault	Remedy
1	Undervoltage	Check power supply voltage
2	Overvoltage	
3	Overtemperature	The error is set at 70°C and canceled at 60°C.
4	Setup error / no setup data	The error cannot be corrected by the customer. Service required or the sensor must be sent to Fife-Tidland GmbH.
5	Amplitude of measuring signal too high	
6	Amplitude of measuring signal too low	
7	General hardware error	

7 TECHNICAL DATA

General information

Dimensions

Gap widths GW: 50,4 mm (standard value)
102 mm

Throat length GL: 70,9 mm (standard value)

→ [figure 3.1, page 3-2](#) and [figure 3.2, page 3-2](#)

Weight

440g (standard value)

Protection class

IP54

IP64 optional

Ambient conditions

Ambient temperature: 5°C – 60°C

Relative humidity: up to 85%, non-condensing

Operating altitude max. 5000m above sea level

Materials used

Housing: Aluminum casting alloy
EN AC-46000 (EN AC- AlSi9Cu3), powder-coated

Protectors: PMMA (polymethylmethacrylate) (EK0471), glued
or
Float glass (EK0472), glued

A data sheet (EK) can be requested for the respective material.

Properties

Light source

Modulated infrared light

Wavelength $\lambda = 875 \pm 25$ nm

Spectral bandwidth $\Delta\lambda = 37$ nm

Sensor field of view

63,5 mm

Linearity

2% max. errors

(GW = 50.4 mm: in the proportional band of 60 mm

GW = 102 mm: in the proportional band of 52 mm)

Web plane change

2% max. error (10% .. 90% of gap width)

Temperature error

2% (at 10°C .. 50°C)

Electrical connection**Power supply**

10V ... 28V

(PELV, negative potential connected to ground)

Overcurrent protection device slow-blow max. 2A)

Power consumption

< 600mW

Output signal0 - 10mA to $\leq 400\Omega$ at 12V (10...15V) Power supply4 - 20mA to $\leq 200\Omega$ at 24V (20...28V) Power supply

Digital data exchange via RS-485 when connected to selected FIFE web guide controllers (e.g. D-MAXE)

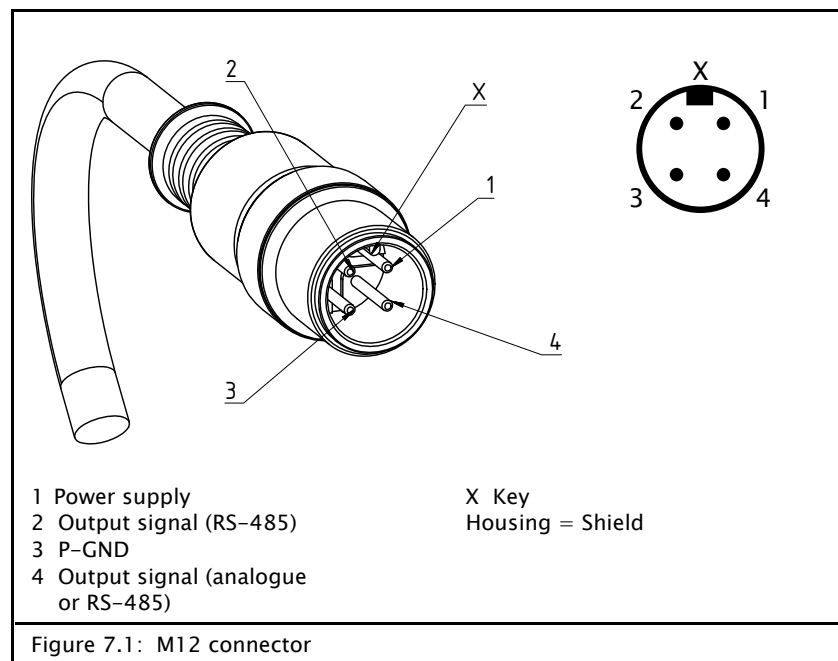
Pin assignment**Standards**

The DSE-23 sensor was constructed in accordance with the standards and regulations of the European Union. A Declaration of Conformity is available.

8 SERVICE

Requests for Service

When requesting service, please have a copy of the order confirmation ready with the order number.

When ordering replacement parts, please indicate, (where possible) Part Number, Drawing Number and Model description.

Please be careful to keep all documents accompanying the product in a safe place. This will allow us to help you more quickly in the event that service is required.

Addresses

To request service, or if you need replacement parts, please contact one of the following addresses.

Fife-Tidland GmbH

Max-Planck-Straße 8 Siemensstraße 13-15
65779 Kelkheim 48683 Ahaus
Deutschland Deutschland
Telefon: +49 - 6195 - 7002 - 0
E-Mail: service@maxcess.eu
Web: www.maxcess.eu

Maxcess

222 West Memorial Road
Oklahoma City, OK 73114, USA
Telefon: +1 - 405 - 755 - 1600
E-Mail: service@maxcessintl.com
Web: www.maxcessintl.com



**EUROPE, MIDDLE EAST
AND AFRICA**

Tel +49.6195.7002.0
sales@maxcess.eu
www.maxcess.eu

**NORTH, CENTRAL
AND SOUTH AMERICA**

Tel +1.405.755.1600
sales@maxcessintl.com
www.maxcessintl.com

CHINA

Tel +86.756.881.9398
info@maxcessintl.com.cn
www.maxcessintl.com.cn

JAPAN

Tel +81.43.421.1622
japan@maxcessintl.com
www.maxcess.jp

INDIA

Tel +91.22.27602633
india@maxcessintl.com
www.maxcess.in

