



INSTRUCTION MANUAL MODEL DFC-90 DANCER-FOLLOWER ARM CONTROL 90 VDC

All of the information herein is the exclusive proprietary property of Maxcess International, and is disclosed with the understanding that it will be retained in confidence and will neither be duplicated nor copied in whole or in part nor be used for any purpose other than for which disclosed.

Copyright 2004, all rights reserved.

Periodically there will be updates to this manual. The latest version is available at www.magpowr.com or by calling 1-800-MAGPOWR (624-7697).

1.0 Introduction

The MAGPOWR Model DFC-90 is a complete solution for follower arm or dancer control applications. The DFC-90 provides a 90 vdc current regulated output to control electromagnetic clutches and brakes. The DFC-90 also provides a small reverse current to minimize the drag torque of the clutch / brake.

The Model DFC-90 has four jumper selectable current ranges. Maximum outputs for the individual ranges are 0.125, 0.25, 0.5 and 1.0 adc. The appropriate range is determined by the current rating of the clutch or brake to be controlled. For best torque control resolution, the lowest current range providing sufficient current for maximum operating torque should be selected.

Connections are provided for an external 1 madc current meter. The meter display will indicate clutch / brake output current as a percentage of the output range selected.

The control circuits are electrically isolated from the power circuits.

2.0 Installation

The DFC-90 is intended for installation on a vertical panel using a DIN 35 rail with the wiring terminals facing down. Figure 1 shows the enclosure dimensions.

Wiring to and from the DFC-90 must be done with double or reinforced insulation or protective screening which provides protective separation. All wiring should comply with the essential requirements of the appropriate standard(s) and is the responsibility of the installer.

Route control signal wiring away from AC wiring. Connect shields of shielded cable to the terminals indicated as "SHIELD". Maximum shield length and maximum length of wires outside of the shield is 3 in. (75 mm).

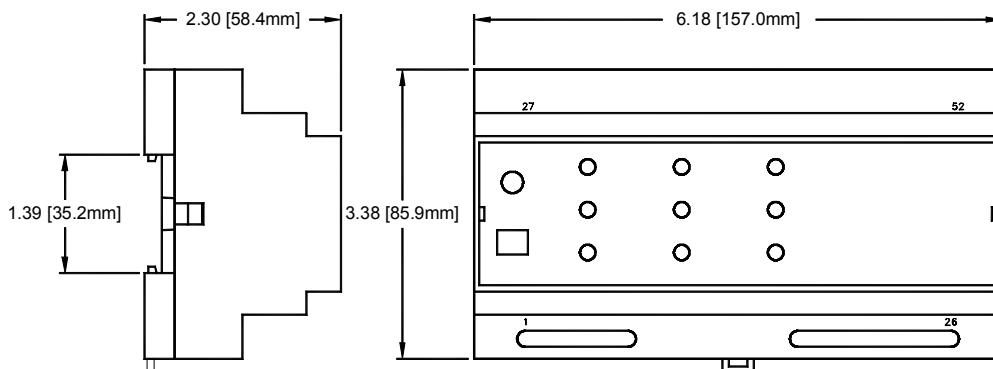

Figure 1
Enclosure Dimensions

3.0 Setup

Remove the enclosure top by inserting a flat blade screwdriver under the retaining tabs in the base (See figure 2). Set the JP1 current range selection jumpers to the range appropriate for the clutch / brake connected to the DFC-90 (See figure 3 for current range settings). The factory setting is 1/8 amp range. Replace the enclosure top.

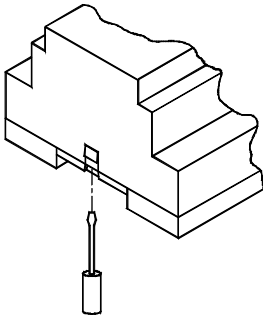
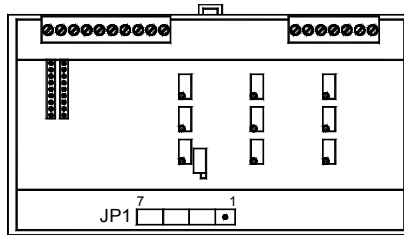

Figure 2
Enclosure Top Removal



JP1 CURENT RANGE							
	7	6	5	4	3	2	1
AMP							
1/8	•	•	•	•	•	•	•
1/4	•	•	•	•	•	•	•
1/2	•	•	•	•	•	•	•
1	•	•	•	•	•	•	•

Figure 3
JP1 Current Range Settings

4.0 Maintenance

The only maintenance that may be required on the DFC-90 is fuse replacement. Replacement of the fuse(2) requires first removing ac power, then opening the enclosure. The enclosure must be re-installed to maintain the IP rating. The enclosure may be opened by inserting a flat blade screwdriver under the retaining tabs in the base (See figure 2).

5.0 Follower Arm Applications

5.1 Electrical Connections

Figure 5 shows the connections that are required for the basic follower arm system. They are:

- 115 vac power input
- 90 vdc output for clutch / brake
- DFP or DFP-2 roll diameter sensor
- 10 kohm tension potentiometer

The clutch / brake output and the remote meter output are not isolated from the AC line and must not be ground referenced. The control inputs are isolated and may be ground referenced.

5.2 Sensor Setup (See Figure 4)

The DFP or DFP-2 position sensor should be at the center of rotation when the follower arm is halfway through its travel. This is an approximate adjustment and is intended to center the sensor position to allow maximum rotation in both directions during operation.

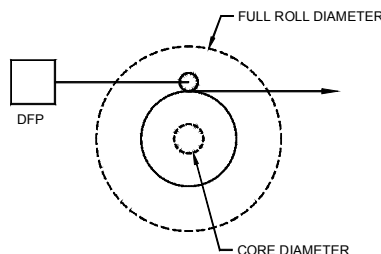

Figure 4

DFP

Install the DFP sensor so that its keyway is pointing towards the top cover when the follower arm is half way through its travel.

DFP-2

To find the electrical center point of pot rotation, use a digital multimeter type ohm meter to measure from the white wire (wiper), to the red or black wire. Turn the potentiometer shaft until the meter reads 500 ohm. Install the DFP-2 sensor so that at the 500 ohm meter reading, the follower arm is halfway through its travel.

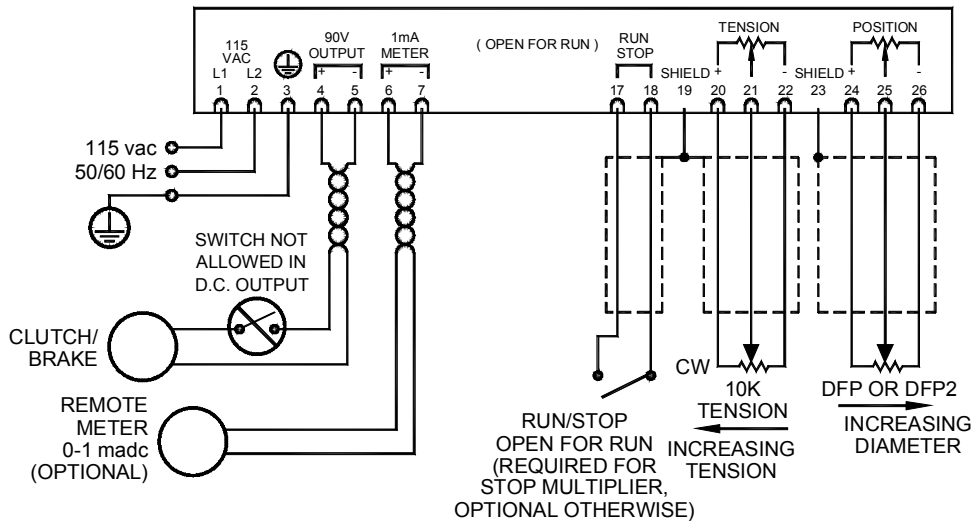

Figure 5
Follower Arm Electrical Connections

5.3 Follower Arm Control Setup

The control adjustments marked with an underline on the label are the only ones needed for follower arm adjustment (see Figure 6). Stop time and Stop multiplier apply to all operating modes and are not distinctively marked.

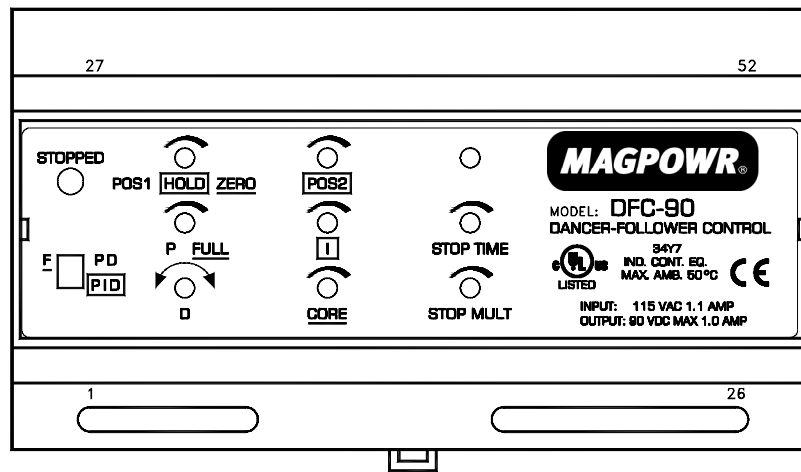

Figure 6

1) Set the following switch and 22-turn potentiometers to the settings given below:

switch	<u>F</u>
<u>ZERO</u>	full Counter Clockwise
<u>FULL</u>	full Clockwise
D	full Counter Clockwise
<u>CORE</u>	full Counter Clockwise
<u>STOP TIME</u>	full Counter Clockwise
<u>STOP MULT</u>	full Counter Clockwise

- 2) Set the external TENSION pot full Clockwise.
- 3) Position the follower arm on an empty core.
- 4) Adjust the **CORE** pot to obtain zero on the remote meter.
- 5) Adjust the **ZERO** pot until the meter just starts to increase, and then reverse adjustment direction to just return the meter to zero.
- 6) From published torque versus current curves adjust the **CORE** pot for the desired output current at core. (Example: y madc to provide xx ft.-lb. at core)
- 7) Place the follower arm at the full roll position, and adjust the **FULL** pot to the desired output current at full roll.

Setup is complete, and the DFC-90 is ready for operation.

Optional adjustments:

Stop Multiplier and Stop Time. The **STOP MULT** pot can be used to increase the torque while the machine is stopping. The increased torque is applied when the RUN/STOP input is closed (terminals 17 and 18). The length of time the increased torque is applied is adjusted by the **STOP TIME** pot. The STOPPED indicator illuminates when the Stop Time expires.

5.4 Operation

Tension is adjusted using the external 10 kohm tension pot.

Rewind taper can be adjusted using the **FULL** pot. The tension will decrease as the roll diameter increases without changing the remote TENSION pot setting. Counter Clockwise rotation of the **FULL** pot will decrease the tension at full roll, thereby increasing the amount of taper.

If the stop multiplier function is used, Clockwise rotation of the **STOP MULT** pot will increase the stopping torque. Clockwise rotation of the **STOP TIME** pot will increase the time that the stopping torque is applied. The **STOP TIME** may be adjusted from 0.2 to 60 seconds.

6.0 Dancer Applications

6.1 Electrical Connections

Figure 7 shows the connections that are required for the basic dancer system. They are:

- 115vac power input
- 90 vdc output for clutch / brake
- DFP or DFP-2 dancer position sensor
- Install jumper between terminals 20 and 21.

The clutch / brake output and the remote meter output are not isolated from the AC line and must not be referenced to ground. The control inputs are isolated and may be ground referenced.

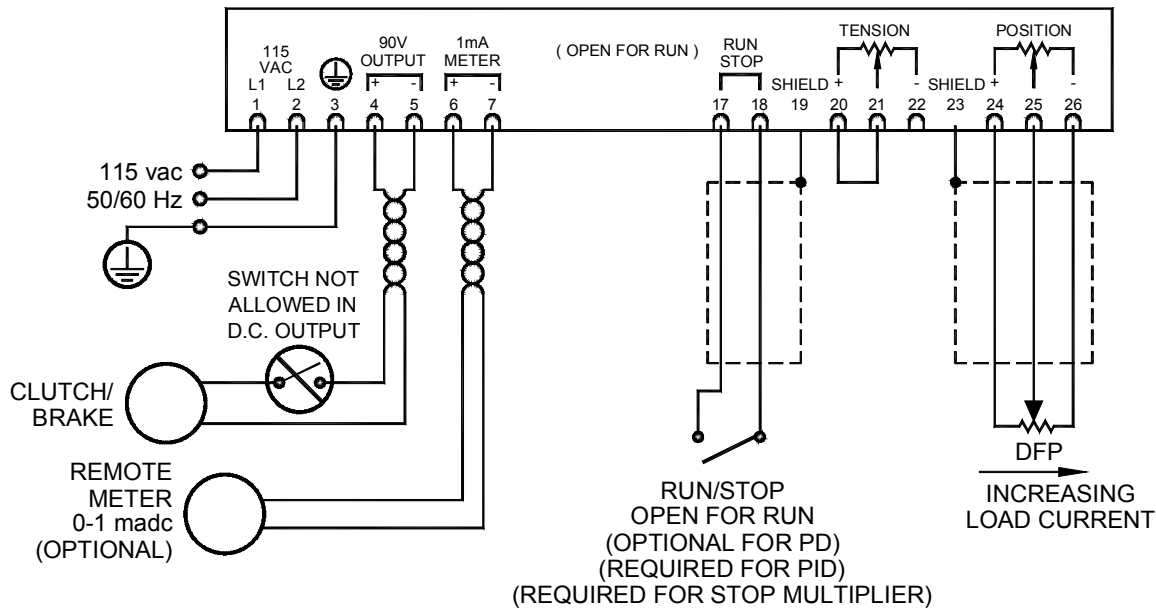

Figure 7
Dancer Electrical Connections

6.2 Sensor Setup

The DFP or DFP-2 position sensor should be at the center of rotation when the dancer is halfway through its travel. This is an approximate adjustment and is intended to center the sensor position to allow maximum rotation in both directions during operation.

DFP

Install the DFP sensor so that its keyway is pointing towards the top cover when the dancer is half way through its travel. This is an approximate adjustment, and is intended to center the sensor position to allow maximum rotation in both directions during operation.

DFP-2

To find the electrical center point of pot rotation, use a digital multimeter type ohm meter to measure from the white wire (wiper), to the red or black wire. Turn the potentiometer shaft until the meter reads 500 ohm. Install the DFP-2 sensor so that at the 500 ohm meter reading, the dancer is halfway through its travel.

6.3 Dancer Control Setup and Tuning

The controls marked on the label without an underline or box are the only ones needed for dancer adjustment (see Figure 6). Stop time and Stop multiplier apply to all operation modes and are not distinctively marked.

1) Set the following switch and 22-turn potentiometers to the settings given below:

switch	PD
P	full Clockwise
D	mid rotation (approximately 11 turns)
CORE	full Counter Clockwise
STOP TIME	full Counter Clockwise
STOP MULT	full Counter Clockwise

2) With the machine running with web, adjust the **POS1** pot to center the dancer roll.

3) Adjust the **D** pot to minimize dancer arm oscillations.

4) If dancer arm oscillations cannot be eliminated, turn the **P** pot Counter Clockwise and repeat step 3.

Calibration is complete, and the DFC-90 is ready for operation.

Optional Adjustments:

Integrator. Many machines run quite successfully after the above adjustments have been made. If the dancer arm moves too much while the roll changes size, the integrator can be turned on to keep the dancer centered.

The control adjustments marked with a box apply to a dancer with integrator.

5) Set the **I** pot full Clockwise.

6) With the machine stopped, set the switch to **PID**. This turns the integrator on.

7) Run the machine near full roll and at a slow speed and use the **POS2** pot to center the dancer. Clockwise rotation of **POS2** moves the dancer up, towards an empty dancer condition.

8) Turn the **I** pot Counter Clockwise until the dancer begins to oscillate around the setpoint position. Then, turn the **I** pot Clockwise until the oscillation stops.

The RUN/STOP input must be used if the integrator is on (switch in **PID** position). The RUN/STOP input should be closed (terminals 17 and 18) when the machine starts its deceleration. The DFC-90 keeps the integrator on until Stop Time expires. Stop Time may be increased by Clockwise rotation of the **STOP TIME** pot. The STOPPED indicator lights when the Stop Time expires. While the STOPPED indicator is lit the DFC-90 provides a hold level current to the clutch / brake. This hold level may be adjusted by turning the **HOLD** pot.

Stop Multiplier and Stop Time. Even if integrator mode is not used, the **STOP MULT** pot can be used to increase the torque while the machine is stopping. The increased torque is applied when the RUN/STOP input is closed (terminals 17 and 18). The length of time the increased torque is applied is adjusted by the **STOP TIME** pot. Using the stop multiplier feature in dancer mode could cause the dancer to oscillate while the machine is stopping.

7.0 Optional Dancer Optimization

After tuning of the dancer, the following method will usually optimize the stability and responsiveness of the dancer. The method begins by placing the dancer in PD mode with a roll diameter near core and reducing the gain to a level which the user may consider unacceptable. Gain will subsequently be increased to a more desirable level. If using PID mode, the dancer is placed in PID mode with a roll diameter near full roll and the integrator is reduced to a level which the user may consider unacceptable. Then, the integrator will be increased to a more desirable level. Sometimes, it may be necessary to first make the PD mode adjustment at a larger roll diameter, and then refine the adjustment near core.

Do not switch between PD/ PID while the machine is running since this may result in a large transient jump in the output.

- 1) With a roll diameter near core and the machine stopped, set the switch to **PD** mode.
- 2) Run the machine and adjust the **POS1** pot to center the dancer arm.
- 3) Decrease the **P** pot by rotating Counter Clockwise until the dancer stabilizes. The **POS1** pot may require readjustment several times in order to keep the dancer roll centered.

DEFINITION: In the following steps the user will have to determine if the dancer is overshooting. To do this, move the stable dancer away from its set position by pushing on the dancer, by bumping the unwind/rewind roll, or by some similar means. If the dancer goes past the set position before settling to the set position, it is overshooting. If the dancer goes straight to the stable position without going past it, the dancer is not overshooting.

- 4) Increase the **P** pot by rotating Clockwise in small steps checking for dancer overshoot at each step. Do this until overshoot is obtained.
- 5) Adjust the **D** pot in small steps checking for dancer overshoot at each step. Do this until the overshoot is eliminated. The direction to adjust **D** for no overshoot is system dependent.
- 6) Repeat steps (4) and (5) until the overshoot cannot be eliminated using the **D** pot, or until the **P** pot is full Clockwise.
- 7) Decrease the **P** pot by the amount necessary to eliminate the overshoot.

Adjustment is now complete for the dancer operating in PD mode. The next steps complete the tuning of the dancer operating in PID mode.

- 8) With a roll diameter near full roll and the machine stopped, set the mode switch to **PID**.
- 9) Run the machine and adjust the **POS2** pot to center the dancer roll.
- 10) Decrease the **I** pot by rotating Counter Clockwise in small steps checking for dancer overshoot at each step. Do this until overshoot is obtained.
- 11) Increase the **I** pot by the amount necessary to eliminate the overshoot.

Adjustment is now complete for the dancer operating in PID mode.

8.0 Follower Arm/ Dancer Options

The DFC-90 is factory adjusted to provide full reverse current with 0 vdc input. If some other current is desired with 0 vdc input, the minimum current potentiometer may be adjusted by cutting out the hole shown on the label and then using a trimpot adjustment tool. Modifying this setting will cause the clutch / brake drag torque to be higher than expected and is not recommended.

9.0 Troubleshooting

9.1 Follower Arm Applications

Symptom	Possible Cause	Solution or Diagnostic
No clutch / brake output.	No AC power.	Verify incoming power is correct voltage and frequency.
	Fuses blown.	Clutch / Brake wires shorted together or shorted to ground.
	Clutch / Brake wires open circuit.	Disconnect clutch / brake wires at the DFC-90 and check for proper clutch / brake resistance between the wires.
	Remote tension adjust potentiometer turned full counter clockwise or not wired properly.	Verify tension pot wiring, turn tension adjust pot full clockwise and follow the calibration procedure in section 5.3. Voltage between terminals 20(+) and 22(-) should be greater than zero and should change as the DFP or DFP-2 is moved through its travel.
	Remote tension potentiometer resistance is less than 10 kohms.	Use a 10 kohm potentiometer for the Remote tension control.
	DFP, DFP-2 position sensor not wired properly or wires shorted.	Verify position sensor is wired properly and follow the calibration procedure in section 5.3. Voltage between terminals 24 and 26 should be 10 vdc. Voltage between terminals 25 and 26 should change as the DFP or DFP-2 is moved through its travel.
	Follower Arm not calibrated.	Follow the calibration procedure in section 5.3.
Clutch / Brake output does not increase during stop time.	RUN/STOP switch not connected or not wired properly.	Verify RUN/STOP switch wiring.
	STOP MULTI plier potentiometer not set properly.	Turn STOP MULT potentiometer clockwise to increase the stopping torque.
Remote meter not working.	Incorrect type of meter.	Meter should be a current meter with 1 ma full scale and no more than 3 Kohm resistance.
	Meter wires shorted or open.	Disconnect meter wiring at the DFC-90 and check for proper meter resistance between the wires.

9.2 Dancer Applications

Symptom	Possible Cause	Solution or Diagnostic
No clutch / brake output.	No AC power.	Verify incoming power is correct voltage and frequency.
	Fuses blown.	Clutch / Brake wires shorted together or shorted to ground.
	Clutch / Brake wires open circuit.	Disconnect clutch / brake wires at the DFC-90 and check for proper clutch / brake resistance between the wires.
	Jumper not installed between 20 and 21.	Install jumper between terminals 20 and 21.
Clutch / Brake output full on or full off.	DFP or DFP-2 sensor not wired properly or wires shorted.	Verify DFP or DFP-2 sensor is wired properly and follow the calibration procedure in section 6.3. Voltage between terminals 24 and 26 should be 10 vdc. Voltage between terminals 25 and 26 should change as the DFP or DFP-2 is moved through its travel.
	Dancer not calibrated.	Follow the calibration procedure in section 6.3.
	DFC-90 in PID mode and RUN/STOP switch is not wired properly.	Verify RUN/STOP switch wiring. PID mode needs a RUN/STOP switch for proper operation.
Clutch / Brake output does not increase during stop time.	RUN/STOP switch not connected or not wired properly.	Verify RUN/STOP switch wiring.
	STOP MULTI plier potentiometer not set properly.	Turn STOP MULT potentiometer clockwise to increase the stopping torque.
Dancer arm hunting during stopping.	STOP MULTI plier is being used.	Turn STOP MULT potentiometer counter clockwise to decrease the hunting during stopping. See Stop Multiplier note at end of section 6.3.
Remote meter not working.	Incorrect type of meter.	Meter should be a current meter with 1 ma full scale and no more than 3 kohm resistance.
	Meter wires shorted or open.	Disconnect meter wiring at the DFC-90 and check for proper meter resistance between the wires.

10.0 Specifications

Supply Voltage:	115vac, +/- 10%, 50/60 Hz, 1.1 amp maximum, sinusoidal
Fuses: F1, F2	1.6 amp, Littelfuse Part No. 21601.6, or Wickmann Part No. 19194-053-FS
Enclosure:	IP20
Climatic Class:	3K3 (EN60721)
Temperature Range:	
Operating:	0° C to 50° C
Storage:	-30° C to 80° C
Relative Humidity:	5% to 85%
Pollution Degree:	2 (IEC664-1)
Altitude:	0 to 2000 m
Compatible Residual Current Device Types:	A or B (IEC755)
Worst Case Fault Current:	1.6 amp ac
Inputs:	
Signal:	DFP or DFP-2 Potentiometer: 1 to 10 kohm, ¼ watt minimum Tension Potentiometer: 10 kohm minimum, ¼ watt minimum
RUN/STOP:	Contact closure, 30 ohm maximum, 0.2 vdc maximum
Outputs:	
Clutch / Brake:	Voltage: -3 to 90 vdc, full wave, phase controlled
Current:	Adjustable in four ranges: -0.004 to 0.125 adc -0.008 to 0.25 adc -0.016 to 0.5 adc -0.032 to 1.0 adc
Regulation:	< 1% of range
Meter Signal:	0 to 1 madc, +/-2% into 3 kohm maximum
DFP or DFP-2 Reference Voltage:	10v +/-2%, 10 madc maximum



MAXCESS INTERNATIONAL COMPANIES



GUIDING · INSPECTION



TENSION CONTROL



SLITTING · WINDING