

Take advantage of quality rolls with narrow slit widths

Tidland's Advantage Series 19 knifeholder provides a minimum slit width of only 19.5 mm (0.768 inches), while delivering high slit quality and extended blade life. A 180° reversible shear blade cartridge allows you to use both sides of the bottom knife ring, extending blade life and reducing operating costs. With the versatility offered by optional crush (score) or razor blade cartridges, the knifeholder can handle a range of materials and applications.

Take advantage of easy setups with a 2.8 mm side stroke distance and easy blade cartridge changes with a simple, set screw retention and quick-disconnect air fittings. The knifeholder body remains in position during the cartridge change, significantly reducing downtime, while blade changes are safe and fast with a snap-on blade locking safety guard.

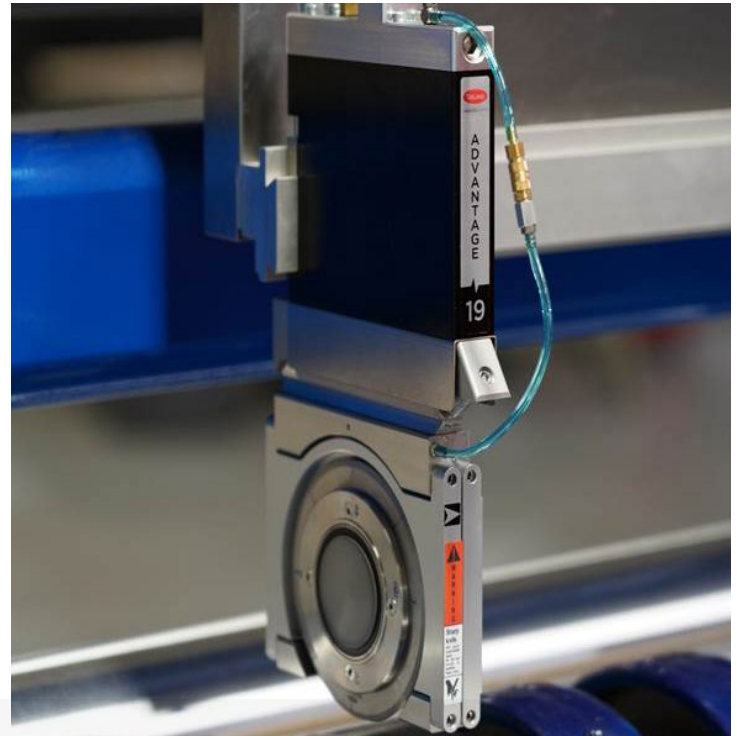

Key Features & General Specifications



- 180° reversible blade cartridge, extending blade life
- Fast blade cartridge removal
- Class I knifeholder and guidebar compatible
- Backward compatible to W19 knifeholder systems
- Precision depth control adjustment for shear blade overlap
- Optional removable blade change safety guard
- Optional slider-valve actuator switch and quick-disconnect air fittings for easy operation
- Optional Shear, Crush (score), and Razor slit cartridges

Minimum Slit Width:
19.5 mm (0.768 inches)

Maximum Web Speed:
1,067 m/min (3,500 ft/min)

Horizontal Stroke Distance (shear only):
2.8 mm (0.11 inches)

Vertical Stroke Distance:
19.5 mm (0.768 inches)

Blade Diameter:
90 mm (3.5 inches)

Operating Air Pressure:
2.7 to 6.2 bar (40 to 90 psi)

ADVANTAGE SERIES OVERVIEW

1. Air input and slider valve
2. Depth control knob
3. Shear cartridge air hose
4. Brake screw
5. Brake gib
6. Cant key
7. Control body dovetail block
8. Cartridge lock set screw
9. Removable/reversible blade cartridge
10. Hole for knife blade lock
11. Blade storage slot
12. 30 or 60 degree blade position

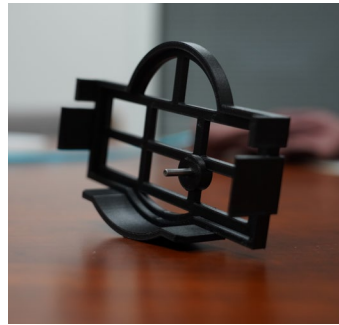

Blade change safety guard (shear only)
(PN 270043481)

SHEER SLITTING

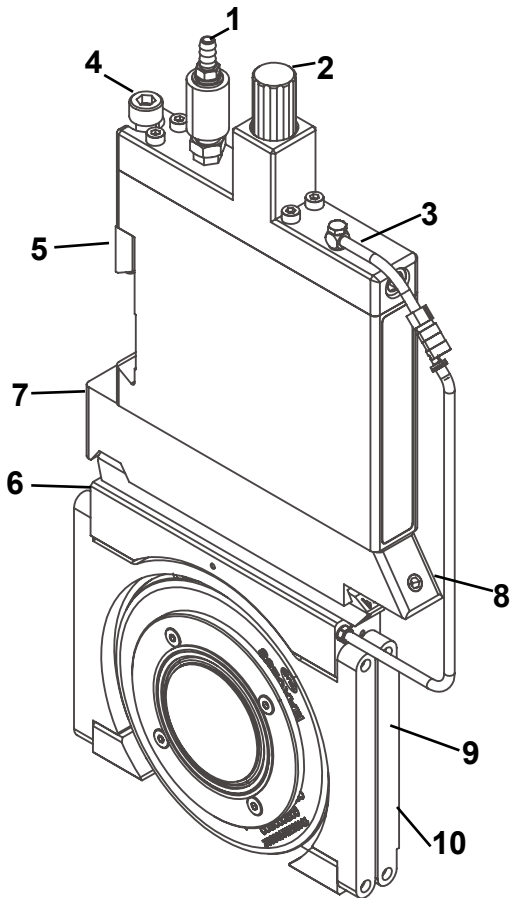

RAZOR SLITTING

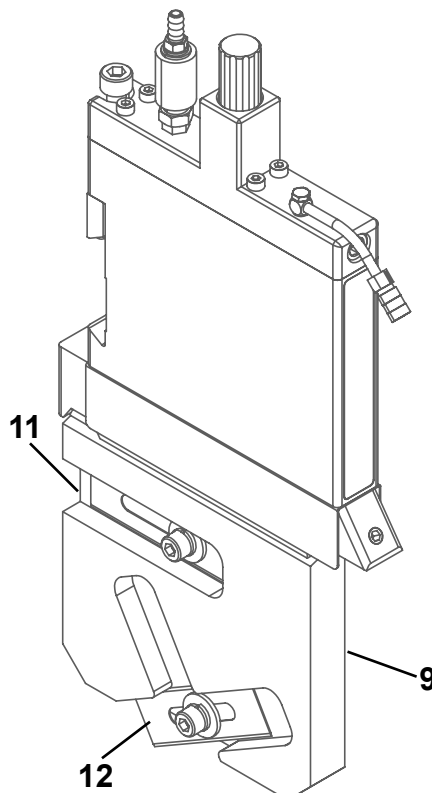

CRUSH SLITTING

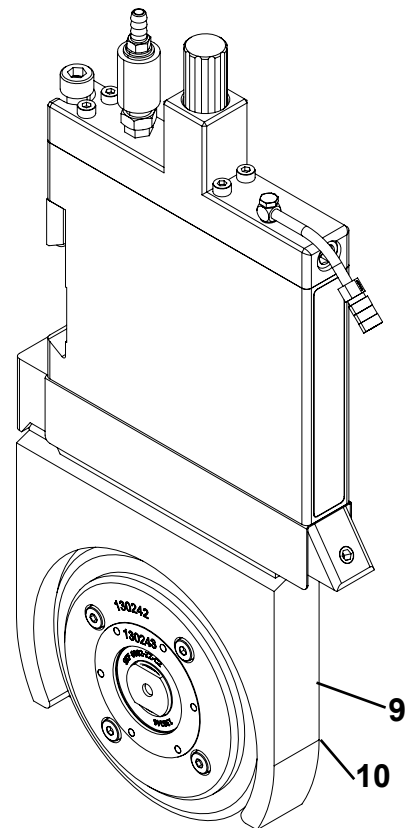

GLOBAL HEADQUARTERS
& AMERICAS

P +1-844-MAXCESS
F +1-405-755-8425
sales@maxcessintl.com

maxcessintl.com

EUROPE
& MIDDLE EAST

P +49-6195-7002-0
F +49-6195-7002-933
sales@maxcess.eu

maxcess.eu

ASIA
PACIFIC

P +86-756-881-9398
F +86-756-881-9393
info@maxcessintl.com.cn

maxcessintl.com.cn



**RELATED PRODUCTS
ASK US ABOUT:**

Cygnus Tension
Controller

D-MAX Enhanced Web
Guiding Controller

