



FIFE-500-XL

Installation and Service Manual



CONTENTS

INTRODUCTION	1-1
About these operating instructions	1-1
CE marking	1-1
Product overview	1-2
SAFETY INSTRUCTIONS	2-1
Instructions for use	2-1
Safety symbols	2-1
Symbols used	2-2
Basic safety information	2-3
INSTALLATION	3-1
Mechanical installation	3-1
Mounting dimensions	3-2
Guiding parameters	3-3
Pneumatic connection to splice table	3-4
Installing the operator interface	3-5
Relocating the operator interface	3-5
Panel mount model	3-6
Wall mount model	3-7
Electrical installation	3-8
Power connection	3-8
Digital inputs and outputs	3-9
Wiring diagrams	3-12
MAINTENANCE	4-1
Sensors	4-2
Operator interface screen	4-2
MODEL NUMBER KEY	5-1
SPECIFICATIONS	6-1
General	6-1
Certifications and environmental compatibility	6-1
Inputs and outputs	6-2
Maximum cable lengths	6-2
SERVICE AND REPLACEMENT PARTS	7-1

About these operating instructions

All of the information herein is the exclusive proprietary property of Maxcess International, and is disclosed with the understanding that it will be retained in confidence and will neither be duplicated nor copied in whole or in part nor be used for any purpose other than for which disclosed.

Copyright 2013, 2016 all rights reserved.

Periodically there will be updates to this manual. The latest version is available on our website or by calling the number on the back page of this publication.

These web guiding systems must not be installed or used in a machine or system which does not comply with the machinery directive 2006/42/EC.

These web guiding systems were designed and manufactured to be installed as Partly Completed Machinery into a machine or partly completed machine.

The instructions must be read and used by all persons who have the responsibility of installing and maintaining these web guiding systems.

These instructions must be retained and incorporated in the technical documentation for the machine or partly completed machinery into which the web guiding system is installed.

Language

These are the original instructions, written in English.

CE marking

The FIFE-500-XL complies with the 2006/42/EC Machinery directive and the 2004/108/EC Electromagnetic Compatibility directive.

Conventions used

All dimensions and specifications are shown in the format **millimeters [inches]** unless otherwise specified.

Product overview

The FIFE-500-XL web guiding system is a complete offset pivot guide and controller in a compact package with an IP54 environmental rating. The FIFE-500-XL is available in many standard roll face, guide span and roller diameters.

The web guiding system is designed for continuous use. The web guiding system has two sensor inputs, a color touchscreen operator interface, and parallel inputs and outputs for remote control and alarms. The web guiding system controls the position of the web by monitoring the web position with sensors mounted on the web path and driving an actuator connected to the guide assembly to steer the web to the desired position. The web guiding system includes a servo center transducer to position the guide parallel to the web path for web threading.

The web guiding system works with most Fife sensors.

Instructions for use

To ensure safe and problem free installation of the web guiding system, the web guiding system must be properly transported and stored, professionally installed, and placed in operation. Proper operation and maintenance will ensure a long service life of the device. Only persons who are acquainted with the installation, commissioning, operation, and maintenance of the system and who possess the necessary qualifications for their activities may work on the web guiding system.

Note: The safety information may not be comprehensive.



Please note the following:

- The content of these operating instructions
- Any safety instructions on the device
- The machine manufacturer's specifications
- All national, state, and local requirements for installation, accident prevention and environmental protection

Safety symbols

Information about safety instructions

The safety instructions and symbols described in this section are used in these operating instructions. They are used to avoid possible dangers for users and to prevent material damage.



SIGNAL WORD

Source of danger and its results

Avoiding dangers

The signal word **DANGER** refers to the danger of death or serious bodily injuries.

The signal word **WARNING** refers to the danger of moderate to severe bodily injuries.

The signal word **CAUTION** refers to the danger of slight to moderate bodily injuries or material damage.

The signal word **NOTICE** refers to the possibility of damage to equipment.

Symbols used

The following safety identification symbols are used in these operating instructions.



WARNING/CAUTION – General danger or important note
Reference to general hazards that may result in bodily injuries or damage to device or material.



WARNING/CAUTION – Danger due to crushing
Reference to danger of injury caused by crushing.



WARNING/CAUTION – Danger due to cutting
Reference to danger of injury caused by cutting.



WARNING/CAUTION – Danger due to voltage, electric shock
Reference to danger of injury caused by electric shock due to voltage.



WARNING/CAUTION – Danger due to hot surfaces
Reference to risk of injury caused by burning.

Basic safety information

Proper use

The web guiding system is intended to be used on machines or systems to guide a web of material.

Indoor operation: see environmental specifications

Improper use

Operation outside the technical specifications

Operation in an Ex-area or intrinsically safe area

Operation as a safety component. The web guiding system does not hold the web position if power fails.

Outdoor operation

Any other use than the proper use shall be deemed inappropriate.

Installation and commissioning

Any web guiding system which is damaged must not be installed or put into operation.

Only perform installation, maintenance or repair tasks on the web guiding system when the machine has been stopped and is secured from being turned on.

Only perform installation, maintenance or repair tasks on the web guiding system when there is no electrical power in the system.

The web guiding system must be securely mounted before being placed in operation.

Only replacement parts obtained from Fife may be used.

No modifications may be made to the web guiding system.

Do not place electrical cables under mechanical strain.



WARNING - Death or injury can result from static electric shocks. Moving webs of material can produce large static voltage potentials. Protect against electric shocks by installing a conductive connection between the terminal marked with the PE symbol on the power connector and the PE circuit of the building or machine.



WARNING - The web guiding system contains rotating and moving parts which could cause injury due to crushing. Appropriate protective guards must be installed by the user according to his use of this product.



WARNING - Death or injury can result from unexpected movement. Protect against unexpected movement by removing electrical power from the web guiding system and the machine into which the web guiding system is being installed.



WARNING - Danger of falling down or muscle or skeletal injury during installation. These web guiding systems, especially the larger designs, are heavy. Appropriate equipment is to be used and the safety rules of the company must be observed.

Operation



WARNING - The web guiding system contains rotating and moving parts which could cause injury due to crushing. Do not touch anything on or in the vicinity of the moving or rotating parts. Appropriate protective guards must be installed by the user according to his use of this product.

Maintenance and repair



WARNING - Death or injury can result from unexpected movement. Protect against unexpected movement by removing electrical power from the web guiding system and the machine into which the web guiding system is installed.



WARNING - Danger of injury from crushing. Maintenance and repair tasks on the web guiding system must be performed only when the machine has been stopped and has been secured from being turned on again.



WARNING - Danger of falling down or muscle or skeletal injury during maintenance and repair. These web guiding systems, especially the larger designs, are heavy. Appropriate equipment is to be used and the safety rules of the company must be observed.

Decommissioning

The web guiding system must be disposed of in accordance with all the applicable national, state and local regulations.

Mechanical installation



WARNING - Death or injury can result from unexpected movement.

Protect against unexpected movement by removing electrical power from the FIFE-500-XL and the machine into which the FIFE-500-XL is installed.



WARNING - Danger of injury from crushing.

Maintenance and repair tasks on the FIFE-500-XL must be performed only when the machine has been stopped and has been secured from being turned on again.



WARNING - Danger of falling down or muscle or skeletal injury during maintenance and repair.

These web guiding systems, especially the larger designs, are heavy. Appropriate equipment is to be used and the safety rules of the company must be observed.

- Install the FIFE-500-XL Web Guiding System in the process line such that the rollers, when in the Servo-Center position, are parallel to the entry and exit rollers.
- The FIFE-500-XL must be installed on a flat, machined surface that is flat within 0.5 [0.02] total indicated runout.
- Ensure that the WEB DIRECTION ARROW on the guide is pointed in the direction of web travel.
- See Figure Sheet 1-558 for factors to consider on where and how to install the FIFE-500-XL Web Guiding System for the best guiding results.
- Integrated sensor mounting is provided for wrap styles exiting towards the base only. Remote sensor mounting must be used for other wrap styles.
- T-nut blocks are delivered in their outermost positions, but are adjustable. To adjust, loosen the clamping screws, adjust the location of the T-nut block(s), then tighten the clamping screws to 3.3 Nm [29 in-lb] of torque after adjustment. See Figure 1.
- Guide will be secured to the machine frame using six customer supplied M8x1.25 bolts. After securing the T-nut blocks in the proper location the M8x1.25 bolts will come up through the machine frame and screw into the T-nut blocks.

Installing the FIFE-500-XL

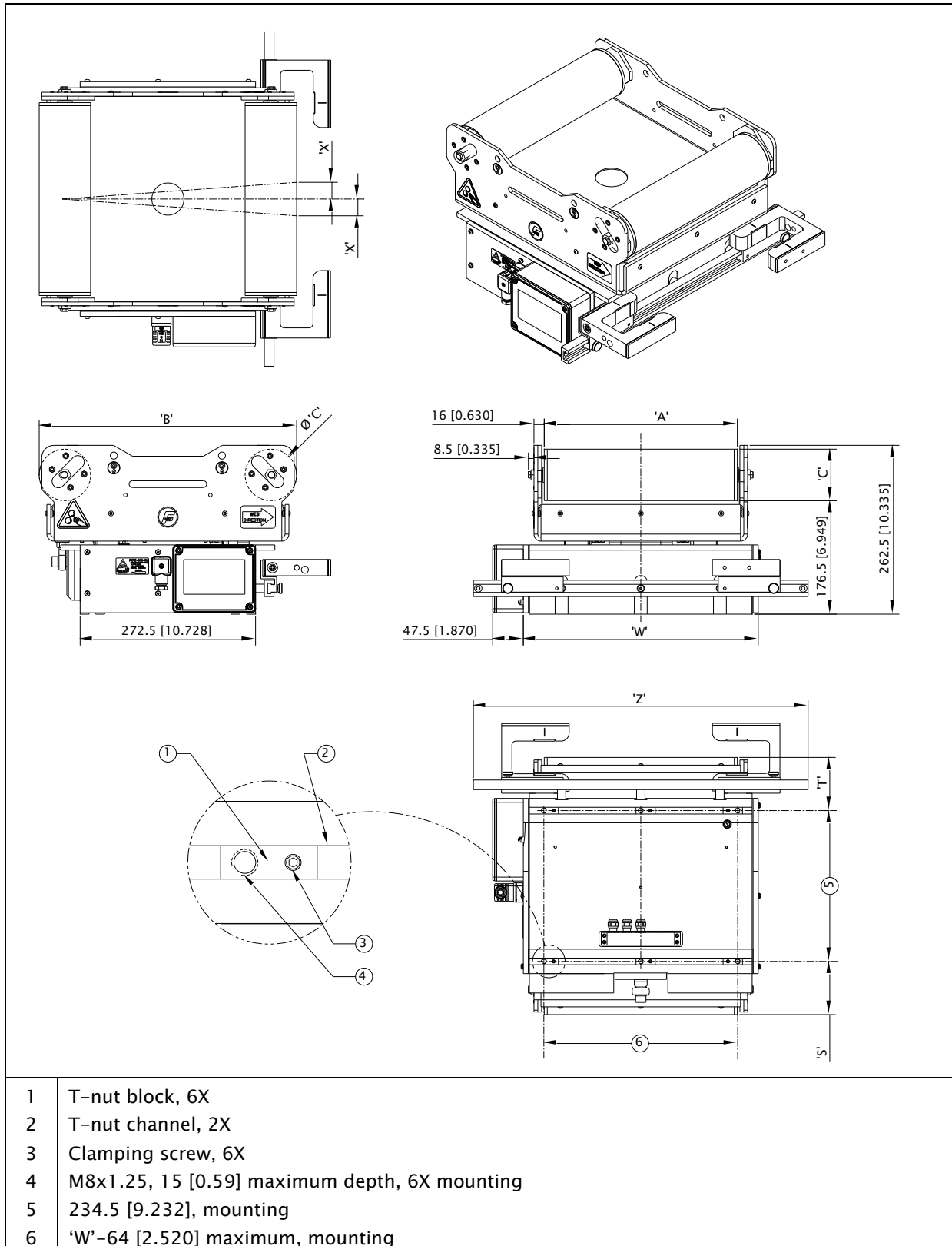

Figure 1. FIFE-500-XL with integrated sensor mounting

Mounting dimensions

Roll Face 'A' mm [inch] (1)	Guide Span 'B' mm [inch] (1)	Roll Diameter 'C' Mm [inch]	Width 'W' mm [inch]	Dimension 'S' mm [inch]	Dimension 'T' mm [inch]	Dimension 'Z' mm [inch]	Max Weight kg [lbs] (2)	
300 [11.81]	400 [15.75]	80 [3.150]	365 [14.370]	82.75 [3.258]	82.75 [3.258]	520 [20.472]	39 [86]	
	500 [19.69]	100 [3.937]		132.75 [5.226]	132.75 [5.226]		43 [95]	
350 [13.78]	400 [15.75]	80 [3.150]		82.75 [3.258]	82.75 [3.258]	570 [22.441]	42 [93]	
	500 [19.69]	100 [3.937]		132.75 [5.226]	132.75 [5.226]		46 [101]	
400 [15.75]	400 [15.75]	80 [3.150] 100 [3.937]		469 [18.465]	82.75 [3.258]	82.75 [3.258]	620 [24.409]	50 [110]
	500 [19.69]				132.75 [5.226]	132.75 [5.226]		55 [121]
	600 [23.62]		232.75 [9.163]		132.75 [5.226]	61 [134]		
500 [19.69]	400 [15.75]	80 [3.150] 100 [3.937]	82.75 [3.258]		82.75 [3.258]	720 [28.346]	54 [119]	
	500 [19.69]		132.75 [5.226]		132.75 [5.226]		59 [130]	
	600 [23.62]		232.75 [9.163]		132.75 [5.226]		65 [143]	
600 [23.62]	400 [15.75]	80 [3.150] 100 [3.937]	629 [24.764]		82.75 [3.258]	82.75 [3.258]	820 [32.283]	57 [126]
	500 [19.69]				132.75 [5.226]	132.75 [5.226]		63 [139]
	600 [23.62]				232.75 [9.163]	132.75 [5.226]		70 [154]
700 [27.56]	400 [15.75]	80 [3.150] 100 [3.937]		82.75 [3.258]	82.75 [3.258]	920 [36.220]	53 [117]	
	500 [19.69]			132.75 [5.226]	132.75 [5.226]		58 [128]	
	600 [23.62]			232.75 [9.163]	132.75 [5.226]		64 [141]	
800 [31.50]	400 [15.75]	80 [3.150] 100 [3.937]		829 [32.638]	82.75 [3.258]	82.75 [3.258]	1020 [40.157]	60 [132]
	500 [19.69]				132.75 [5.226]	132.75 [5.226]		66 [146]
	600 [23.62]				232.75 [9.163]	132.75 [5.226]		73 [161]
900 [35.43]	400 [15.75]	80 [3.150] 100 [3.937]	82.75 [3.258]		82.75 [3.258]	1120 [44.094]	68 [150]	
	500 [19.69]		132.75 [5.226]		132.75 [5.226]		75 [165]	
	600 [23.62]		232.75 [9.163]		132.75 [5.226]		83 [183]	

- 1) The dimensions A, B, and C may be found from the first three digits of the model number following the characters "MW".
- 2) The weight is a maximum with 100 mm rollers and the splice table. The 80 mm rollers reduce the weight by 2% and the removal of the splice table reduces the weight by about 10%.

Guiding parameters

Roll Face 'A' mm [inch] (1)	Guide Span 'B' mm [inch] (1)	Max Correction 'X' mm [inch]	Max correction speed mm/sec [inch/sec]
300 [11.81]	400 [15.75]	14.61 [0.58]	140 [5.51]
	500 [19.69]	15.78 [0.62]	150 [5.91]
350 [13.78]	400 [15.75]	14.61 [0.58]	140 [5.51]
	500 [19.69]	15.78 [0.62]	150 [5.91]
400 [15.75]	400 [15.75]	12.99 [0.51]	140 [5.51]
	500 [19.69]	14.45 [0.57]	150 [5.91]
	600 [23.62]	13.86 [0.55]	137 [5.39]
500 [19.69]	400 [15.75]	19.15 [0.75]	140 [5.51]
	500 [19.69]	21.31 [0.84]	150 [5.91]
	600 [23.62]	20.44 [0.80]	137 [5.39]
600 [23.62]	400 [15.75]	21.63 [0.85]	140 [5.51]
	500 [19.69]	24.87 [0.98]	150 [5.91]
	600 [23.62]	24.91 [0.98]	137 [5.39]
700 [27.56]	400 [15.75]	21.63 [0.85]	140 [5.51]
	500 [19.69]	24.87 [0.98]	150 [5.91]
	600 [23.62]	24.91 [0.98]	137 [5.39]
800 [31.50]	400 [15.75]	21.22 [0.84]	140 [5.51]
	500 [19.69]	25.16 [0.99]	150 [5.91]
	600 [23.62]	26.41 [1.04]	137 [5.39]
900 [35.43]	400 [15.75]	21.22 [0.84]	140 [5.51]
	500 [19.69]	25.16 [0.99]	150 [5.91]
	600 [23.62]	26.41 [1.04]	137 [5.39]

Pneumatic connection to splice table

1. Connect pneumatic lines to the two pneumatic fittings to allow operation of the pneumatic clamp.
2. Operating pressure range for the pneumatic clamp is 34–552 kPa [5–80 psi].



CAUTION - Damage to the pneumatic clamp due to high pressure. Do not connect an air source of greater than 552 kPa [80 psi] to the pneumatic clamp. Use of a pressure regulator is recommended.

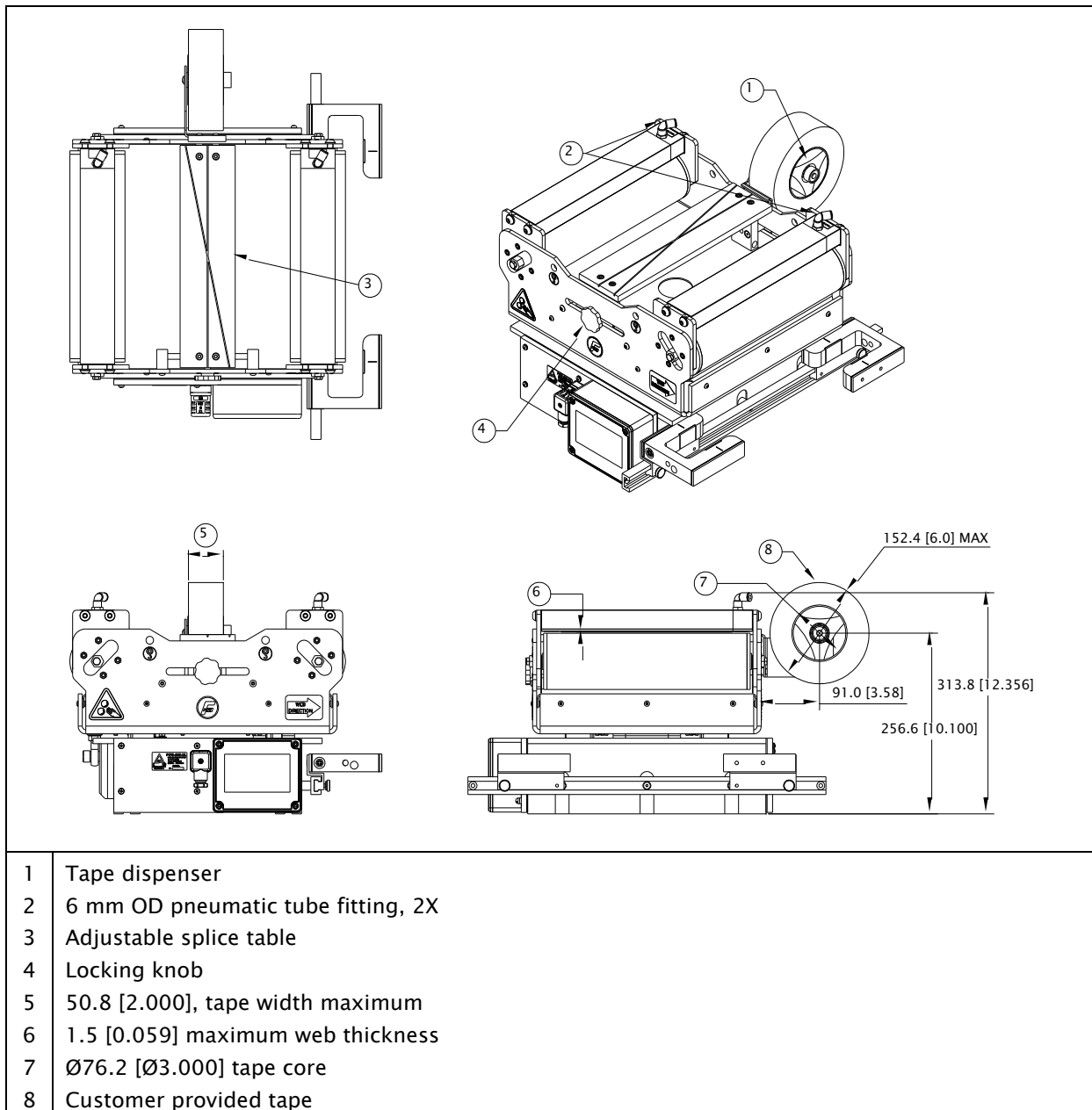

Figure 2. Splice table with tape dispenser

Installing the operator interface

Operator interface relocation

The Operator Interface may be mounted on either end of the Base Assembly. If it is desired to relocate the OI from one end of the Base Assembly to the other, use the following procedure.

1. Disconnect power from the FIFE-500-XL unit.
2. Using a 3 mm Allen wrench, remove the four screws that retain the OI to the Base Assembly end plate.
3. The shroud, which is the spacer between the OI and the end plate, should be retained with the OI.
4. Disconnect the cable between the OI and the Base Assembly.
5. Re-direct the cable with the female connector to the opposite end of the Base Assembly by pulling the cable through the bottom channel of the extrusion.
6. Reconnect the cable to the OI.
7. Route the sensor cable through the appropriate slot in the shroud, then mount the OI with the shroud to the end plate and secure it with the four screws that were removed, previously.



WARNING - Death or injury due to cutting or crushing.



The operator interface should not be used while the machine is running. If it is necessary for the operator to use the operator interface while the machine is running, precautions must be taken to protect the operator from injury due to moving material and machinery. This can be accomplished by either surrounding the operator interface with guarding, or by remote mounting the operator interface in a safe location.

The operator interface can be mounted through a panel or on a wall. See the sections on following pages for details on remote mounting of the OI.

Panel mount model

1. Order mounting kit P/N 29L215802001 when mounting the Operator Interface remotely in a panel.
2. Order an Operator Interface extension cable P/N 29L215680XXX. 20 meter maximum length.



CAUTION - Never place electrical cables under mechanical strain. Always provide mechanical support of wiring with either clamps or flexible or rigid conduit.

Units are in millimeters [inches].

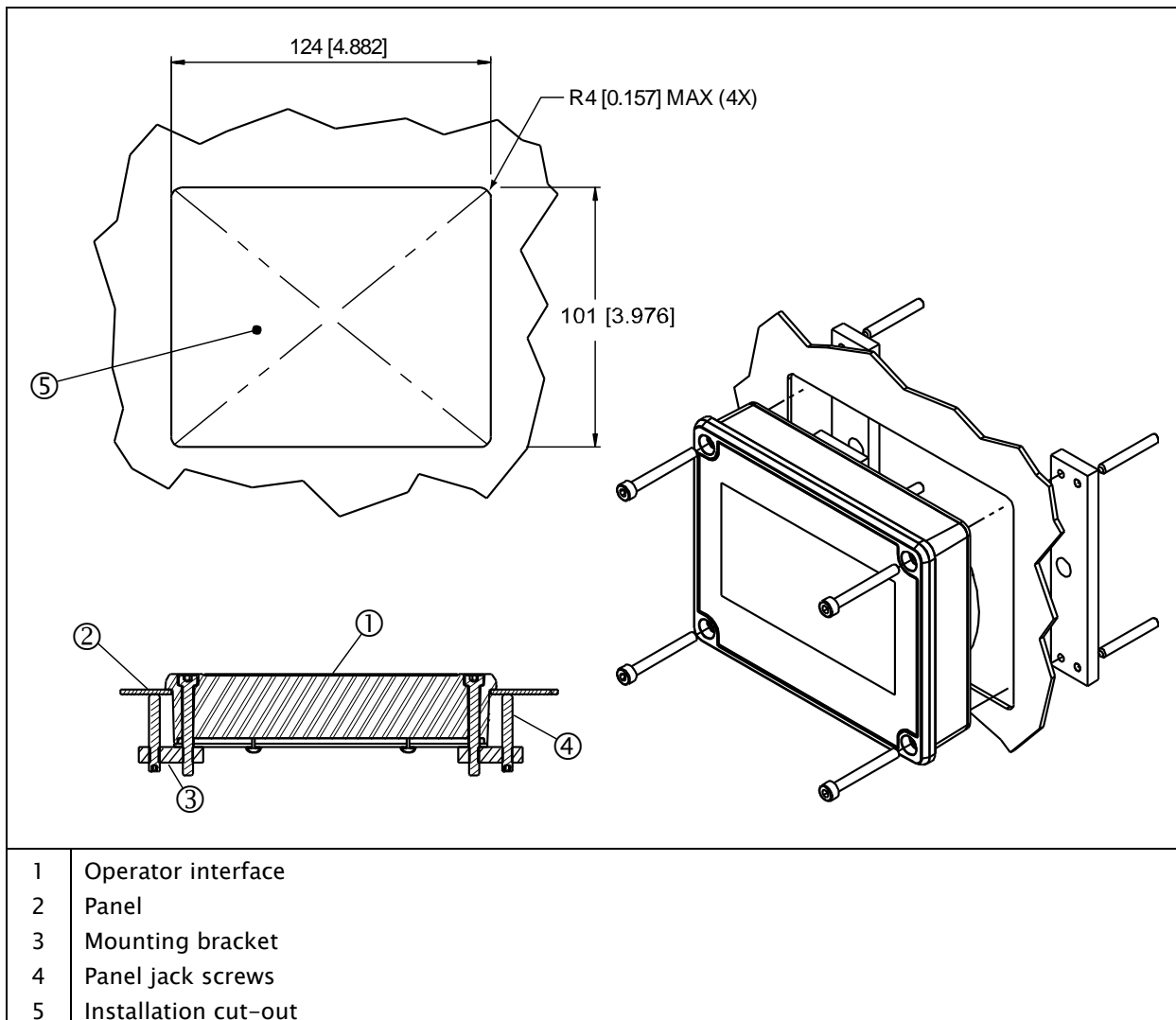

Figure 3. Operator interface panel mount kit installation

Wall mount model

1. Use existing hardware (guide mounted) when mounting the Operator Interface remotely on a wall.
2. Order an Operator Interface extension cable P/N 29L215680XXX. 20 meter maximum length.



CAUTION - Never place electrical cables under mechanical strain. Always provide mechanical support of wiring with either clamps or flexible or rigid conduit.

Units are in millimeters [inches].

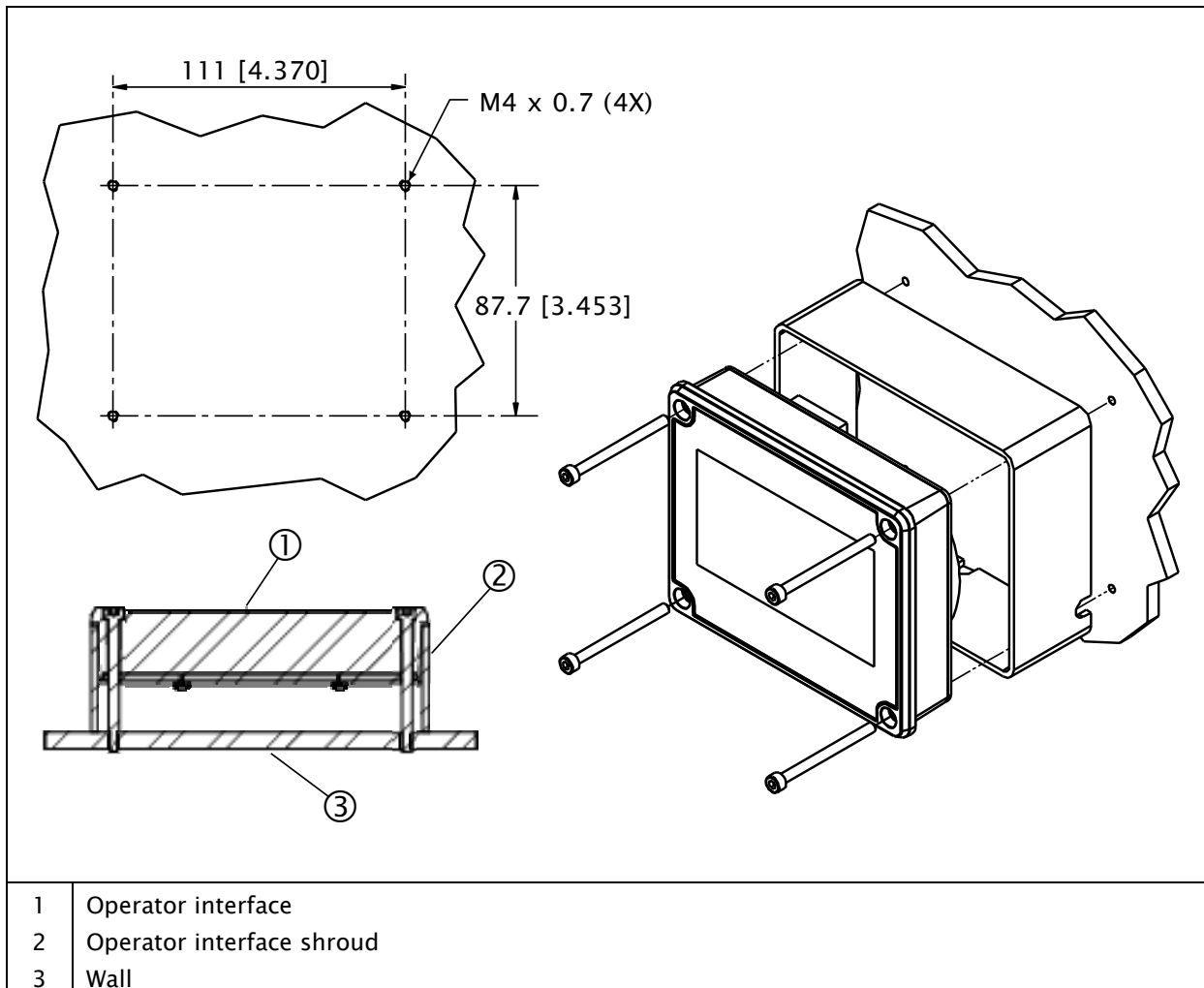

Figure 4. Operator interface wall mount kit installation

Electrical installation

Reference drawings

Description	Drawing Number
Wiring diagram	217299
Cable selection chart	217914

Power connection

Operating voltage range and current rating are listed in Specifications (page 6-1), and shown on the label on the base housing.

All wiring must comply with the essential requirements of the appropriate standard(s) and is the responsibility of the installer.

Wiring to the web guiding system must be insulated copper wire with a temperature rating of at least 80°C. The wire size should be 0.82 mm² (18 AWG).

Note: The negative power connection, pin 2, is internally connected to the PE connection. This connection is only used for EMC compliance.

1. Power cable is supplied by the customer. For an assembled 5 m (16.4 foot) power cable with connector and gasket, order part number 29L214658005.

2. Power connectors available based on cable outside diameter.

Cable Diameter	Connector Order Number
4.5 [0.177] – 7.0 [0.276]	29L91074001
6.0 [0.236] – 10.0 [0.390]	29L91074002
8.0 [0.315] – 14 [0.551]	29L91074003

3. Assembly supplied with one connector part number 29L91074001 and one sealing gasket part number 29L91074004.
4. Connect a 24 VDC +/-25% power supply to pins 1 and 2 of the power connector. Pin 1 should be positive and pin 2 should be negative. See Figure 5.
5. Connect the PE of the building or machine to the power connector terminal marked with the PE symbol.  See Figure 5.
6. Place the power connector on the mating connector on the web guiding system and secure with the mounting screw. Be sure the gasket is installed at the mating interface of the connectors.



WARNING - Death or injury can result from static electric shocks. Moving webs of material can produce large static voltage potentials. Protect against electric shocks by installing a conductive connection between the terminal marked with the PE symbol on the power connector and the PE circuit of the building or machine.



CAUTION - Never place electrical cables under mechanical strain. Always provide mechanical support of wiring with either clamps or flexible or rigid conduit.

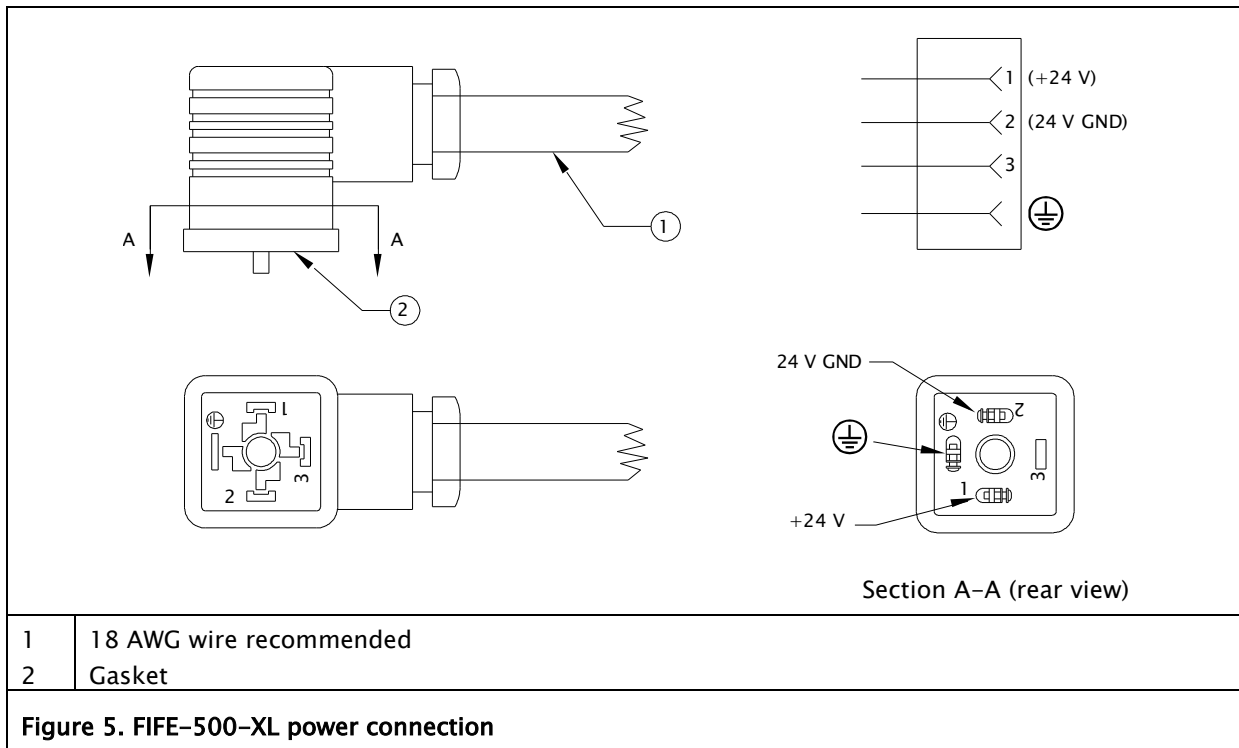

Figure 5. FIFE-500-XL power connection

Digital inputs and outputs

Digital inputs and outputs are available for remote control and signalling functions. There are 6 digital inputs allowing control of the following modes External Lock, Automatic, Manual, Servo-Center, Jog, RGPC, and sensor selection. There are 4 digital outputs and are initially configured as alarms for Loss of Null, Centered, Motor Blocked, and Power OK. See the following page for the default configuration.

See Figure 6 for terminal connections of the digital inputs and outputs on the motor controller board located in the base assembly housing. Figure 7 is the wiring diagram of the FIFE-500-XL.

Table 1. Digital input matrix default configuration

0 = LOW
 1 = HIGH
 - = IGNORE

Note: To ensure that a command is properly executed, all pertinent inputs for each command must be switched high or low within 20 ms of each other and maintained for at least 30 ms.

MODE	INPUTS					
	5	4	3	2	1	0
EXTERNAL LOCK	-	-	-	-	-	1
AUTOMATIC	-	-	0	0	1	-
MANUAL	-	-	0	1	0	-
SERVO-CENTER	-	-	1	0	0	-
JOG Minus *	0	1	-	-	-	-
JOG Plus *	1	0	-	-	-	-
RGPC Minus *	0	1	-	-	-	-
RGPC Plus *	1	0	-	-	-	-
RGPC RESET *	1	1	-	-	-	-
Sensor S1 (Single Edge Guiding) **	-	-	0	1	1	-
Sensor S2 (Single Edge Guiding) **	-	-	1	1	0	-
Sensor S1 - S2 (Center-guiding) **	-	-	1	1	1	-

* Inputs 4 & 5 are used to provide Jogs while in Manual and Servo Center modes, and RGPC functions while in Automatic mode.

** Sensor selection is allowed in Manual and Servo Center modes, only. Sensor selection must be momentary commands.



WARNING - Death or injury can result from unexpected movement.

If the timing requirements of the digital inputs are not met, unexpected motion of the guide could result when a sensor selection is misinterpreted as a mode change to Servo Center or Auto.

Table 2. Digital output matrix default configuration

1 = ACTIVE

- = IGNORE

STATUS	OUTPUTS*			
	D	C	B	A
LOSS OF NULL (AUTOMATIC MODE)	-	-	-	1
CENTERED (SERVO-CENTER MODE)	-	-	1	-
MOTOR BLOCKED	-	1	-	-
POWER OK	1	-	-	-

* Digital outputs are active low

Wiring diagrams

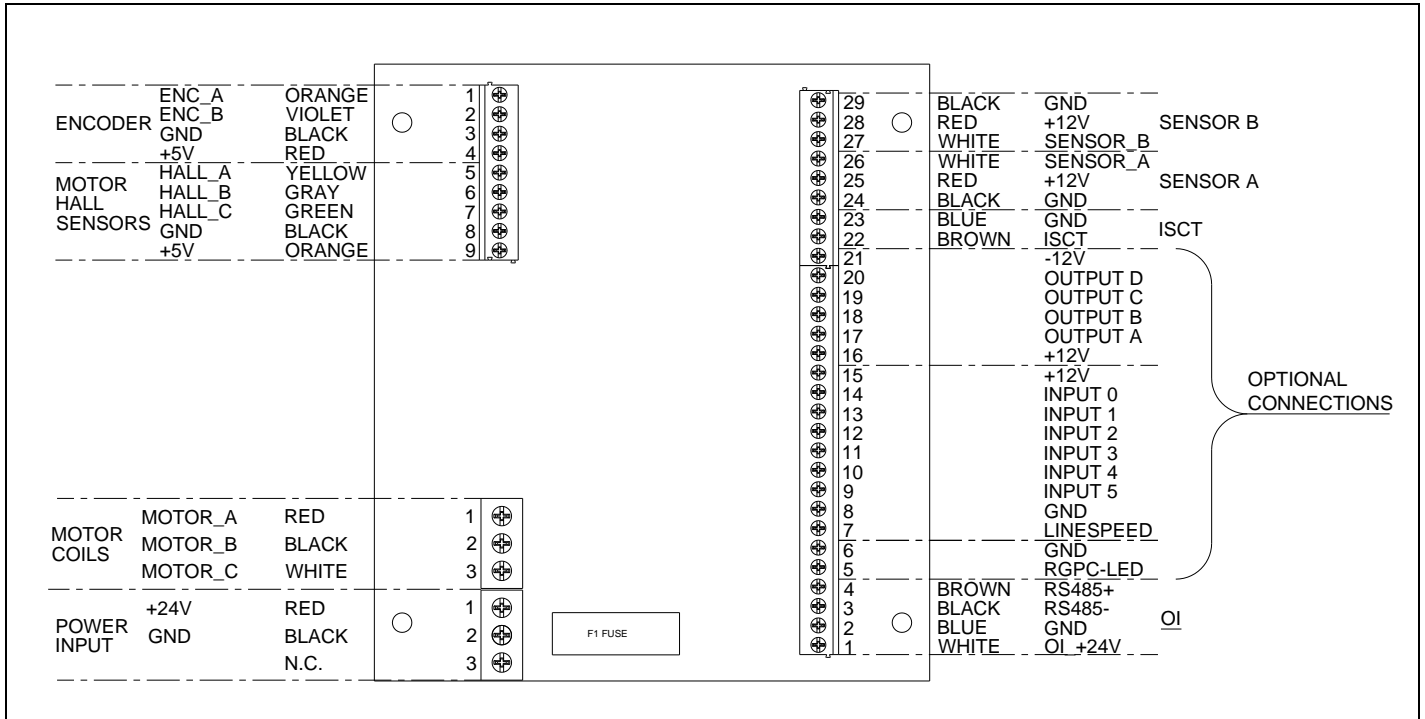

Figure 6. Motor controller board connections

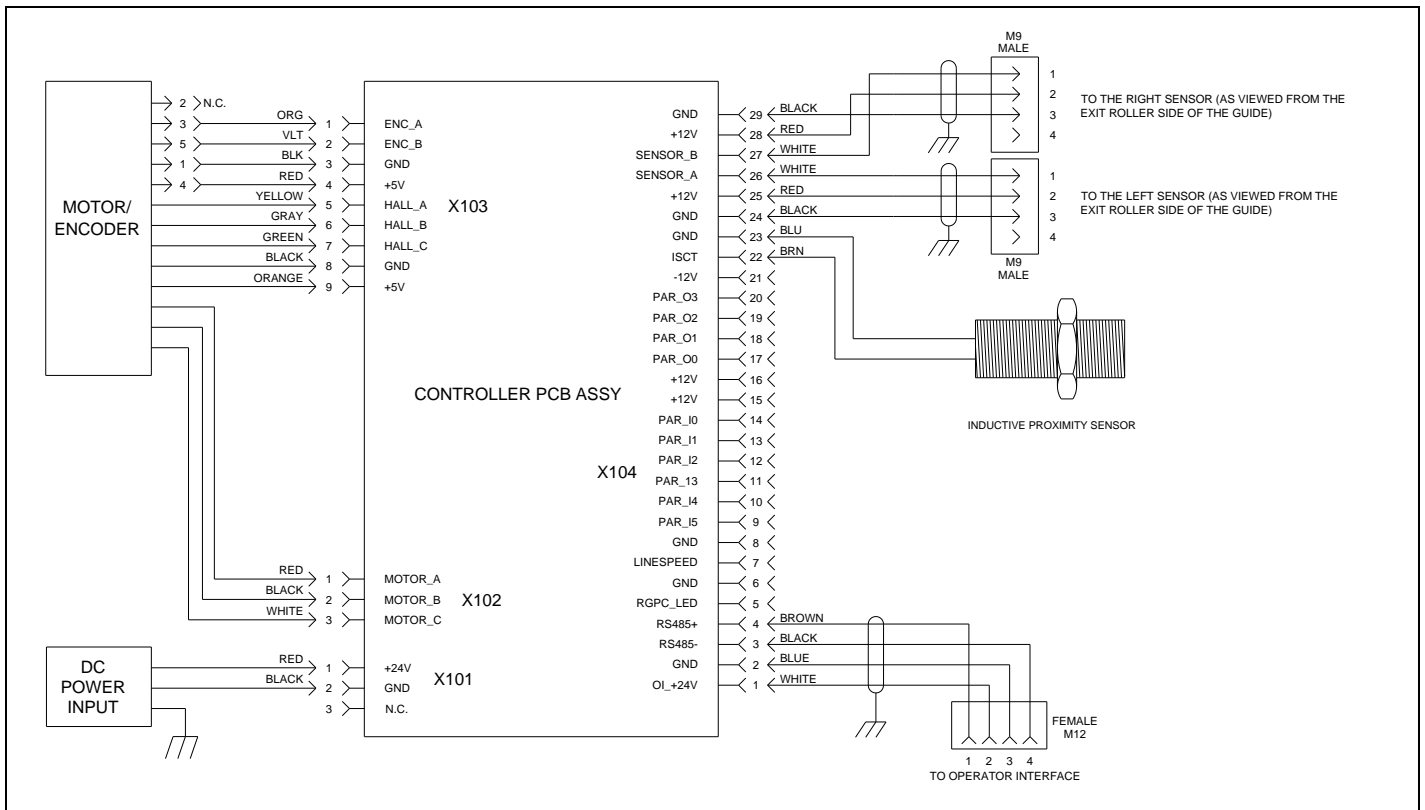

Figure 7. FIFE-500-XL basic wiring diagram

Wiring diagrams

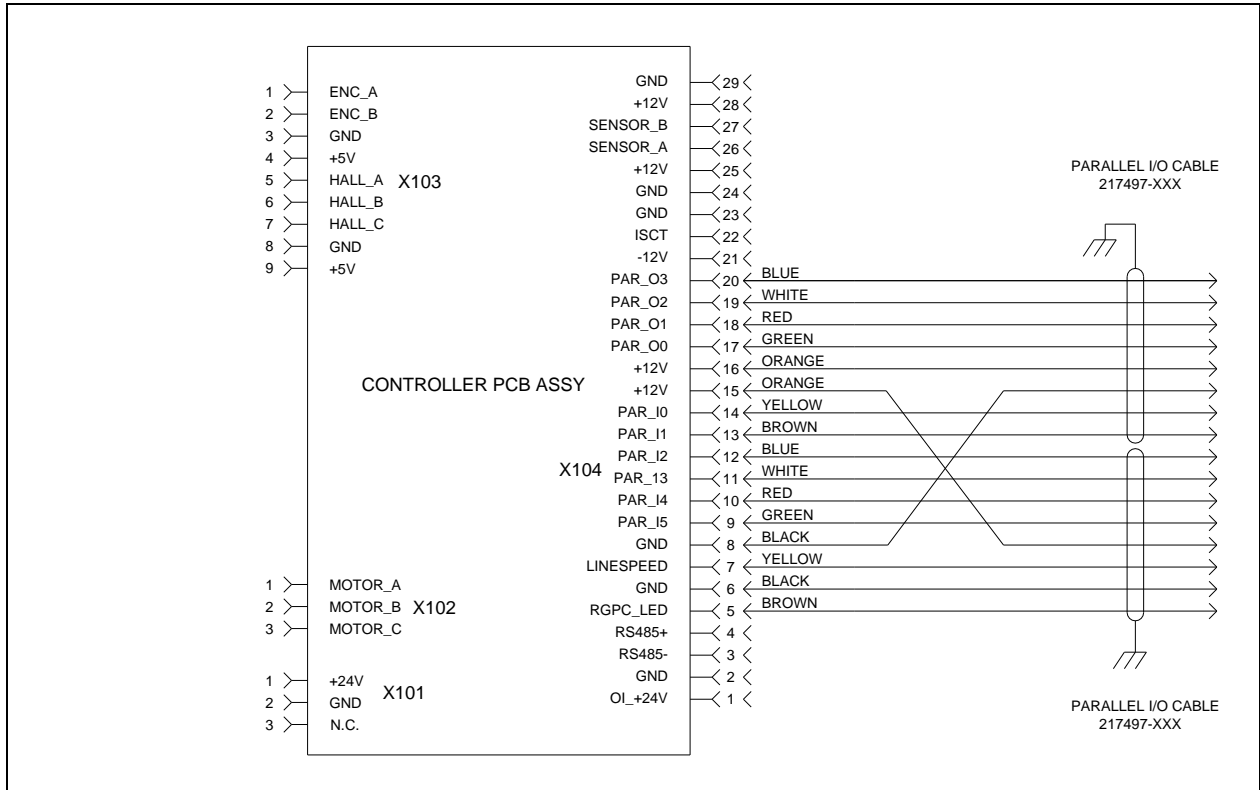

Figure 8. FIFE-500-XL parallel I/O connections

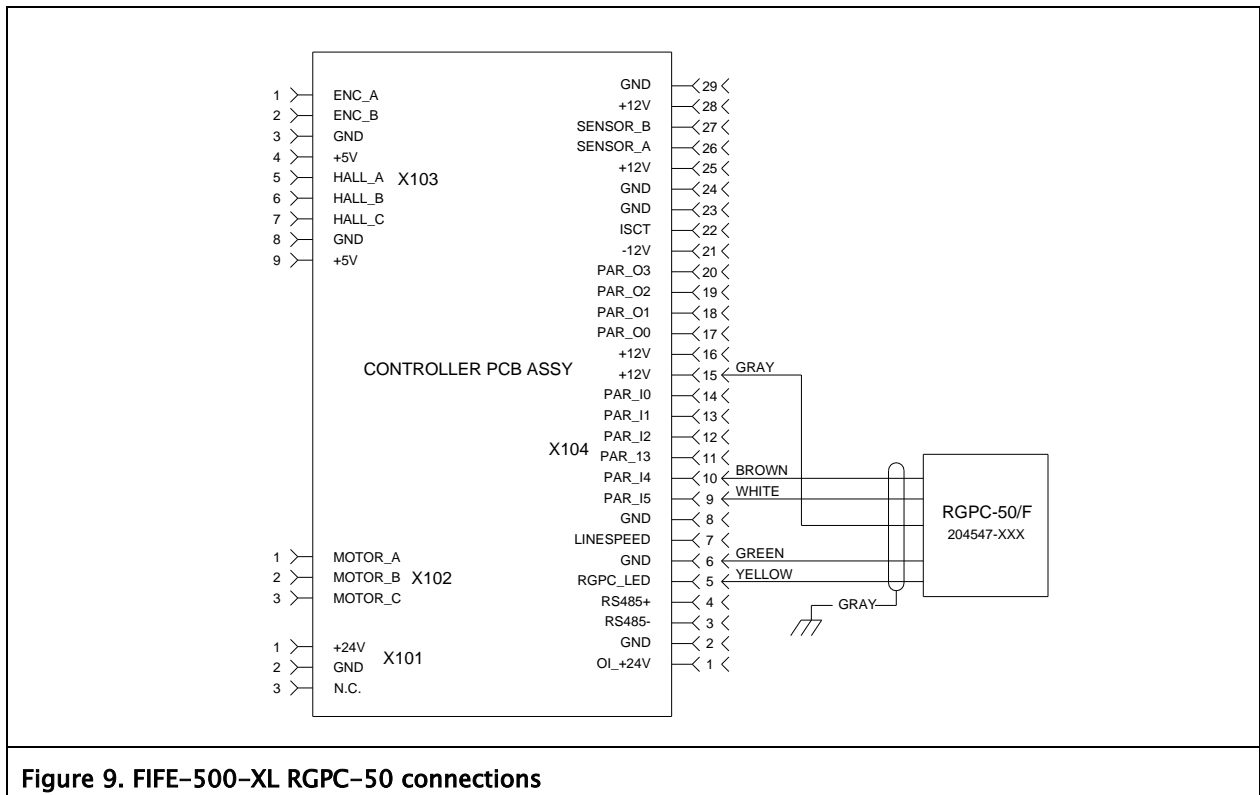

Figure 9. FIFE-500-XL RGPC-50 connections

Wiring diagrams

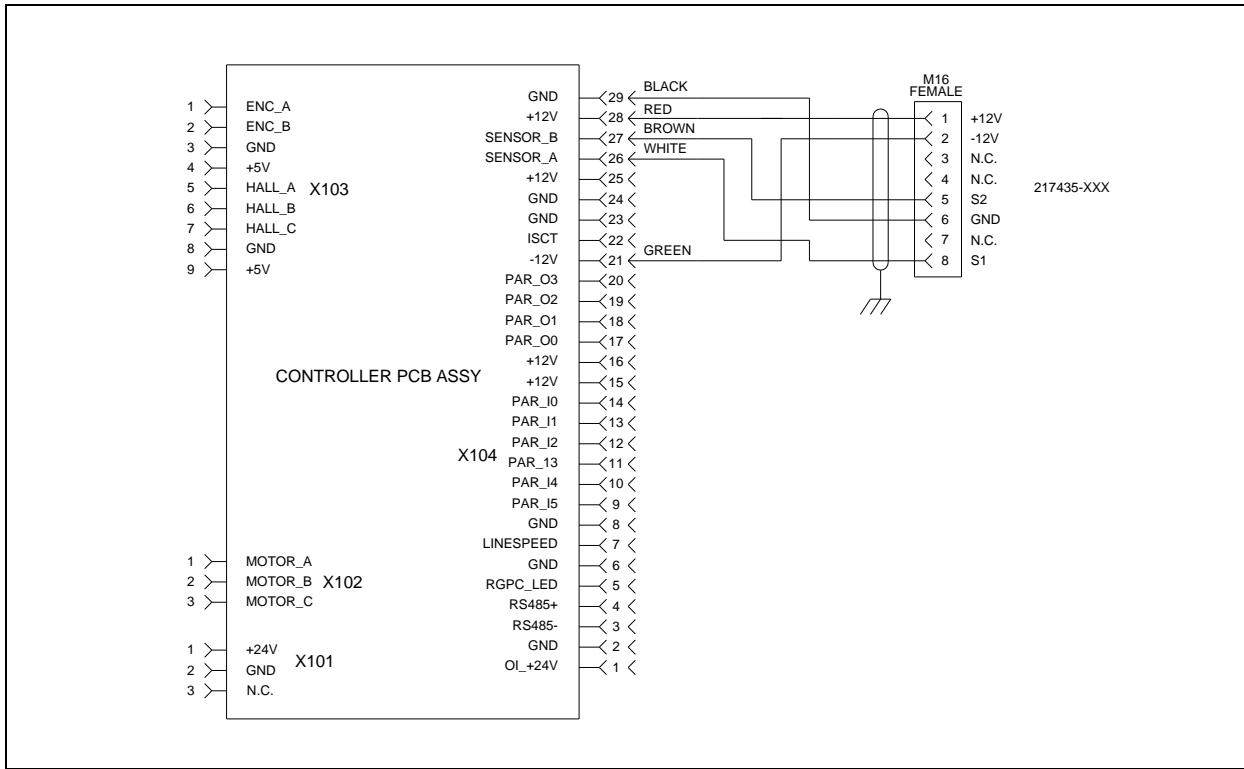

Figure 12. FIFE-500-XL sensor connections for sensors SE-26A, SE-46A-C, DSE-17

Maintenance



WARNING – Death or injury can result from unexpected movement. Protect against unexpected movement by removing electrical power from the FIFE-500-XL and the machine into which the FIFE-500-XL is installed.



WARNING – Danger of injury from crushing. Maintenance and repair tasks on the FIFE-500-XL must be performed only when the machine has been stopped and has been secured from being turned on again.



WARNING – Danger of falling down or muscle or skeletal injury during maintenance and repair. These web guiding systems, especially the larger designs, are heavy. Appropriate equipment is to be used and the safety rules of the company must be observed.



WARNING – To prevent death or injury, always use standard Lockout/Tagout procedures.

- Maintenance schedules are recommended intervals only. Ambient conditions can influence intervals considerably. Therefore, adjustments to the recommendations must be made accordingly.
- Guide has a protection class rating of IP 54. The “5” defines limited ingress of dust permitted, while the “4” defines protection against water splashed from all directions. Note that the guide is only protected from water splashes and no jets of water are permitted. Adhere to protection class rating IP 54 during all maintenance procedures.
- General cleaning of the complete assembly shall be completed once a week, or as required by usage and environmental conditions. Cleaning shall consist of wiping down components as necessary with a clean and dry cloth. Compressed air or a shop vacuum may also be used as necessary.
- Rollers are designed to be mechanically maintenance free, including ball bearings. If issues exist with bearings or other roller components contact customer service for further instructions. Surfaces of the rollers should be cleaned every four weeks or as required by usage and environmental conditions.

Maintenance

Sensors

Sensors shall be cleaned as necessary in order to ensure lenses, transmitters, and/or receivers have a clear path to detect the web. Cleaning shall consist of wiping down components as necessary with a clean and dry cloth. Compressed air or a shop vacuum may also be used as necessary.

Operator interface screen

The Operator Interface (touchscreen) should be cleaned as necessary in order to ensure clear visibility of the menus. Cleaning shall consist of wiping down components as necessary with a clean and dry cloth. Commercial liquid cleaner may be used if necessary, but ensure that a small amount of liquid is placed on the cloth before wiping down the screen. Do not directly spray the screen. Compressed air or a shop vacuum may also be used as necessary.

Model number key

The model number and serial number are shown on the back side of the base housing.

The model number consists of the base model “MW” followed by 9 digits specifying the options.

Format: MW - A B C D D E F G H

See Figure 1 for an illustration of the A, B, and C dimensions.

A = Roll Face dimension

B = Guide Span dimension

C = Roller Diameter

A	Roll Face	B	Guide Span	C	Roller Diameter
1	300 [11.81]	1	400 [15.75]	0	NONE
		2	500 [19.69]	3	80 [3.150]
				4	100 [3.937]
2	350 [13.78]	1	400 [15.75]	0	NONE
		2	500 [19.69]	3	80 [3.150]
				4	100 [3.937]
3	400 [15.75]	1	400 [15.75]	0	NONE
		2	500 [19.69]	3	80 [3.150]
				3	600 [23.62]
4	500 [19.69]	1	400 [15.75]	0	NONE
		2	500 [19.69]	3	80 [3.150]
				3	600 [23.62]
5	600 [23.62]	1	400 [15.75]	0	NONE
		2	500 [19.69]	3	80 [3.150]
				3	600 [23.62]
6	700 [27.56]	1	400 [15.75]	0	NONE
		2	500 [19.69]	3	80 [3.150]
				3	600 [23.62]
7	800 [31.50]	1	400 [15.75]	0	NONE
		2	500 [19.69]	3	80 [3.150]
				3	600 [23.62]
8	900 [35.43]	1	400 [15.75]	0	NONE
		2	500 [19.69]	3	80 [3.150]
				3	600 [23.62]

Model number key

DD = Sensor Type

DD	Sensor Type
00	None
01	SE-11 without Air Sweep
02	SE-17 with Air Sweep
03	SE-17 without Air Sweep
04	SE-22 without Air Sweep
05	SE-23 without Air Sweep
06	SE-31-IP (2 in. Gap) without Air Sweep
07	SE-42R with Integrated Air Sweep
08	SE-22 with Air Sweep
09	SE-23 with Air Sweep
10	SE-26A
11	SE-46
12	DSE-17
13	SE-38
14	SE-44

E = Sensor Quantity

0 = None

1 = 1 Sensor

2 = 2 Sensors

F = Type of Sensor Mounting Bracket Assembly

0 = None

1 = Standard

2 = Fine Adjustment

G = Splice Table and Tape Dispenser

G	Splice Table	Tape Dispenser
0	No	No
1	Yes	No
2	Yes	Yes

H = Roller Coating

H	Roll Finish
1	Standard
2	Hard Coat Anodize
3	Dragon Elite II Plasma Coat
4	Rubber Cork Tape
5	11036 Plasma Coat

Example Model Number: MW-223052224

This model number specifies a roll face dimension of 350 [13.78], a guide span of 500 [19.69], a roller diameter of 80 [3.150], a quantity of two SE-23 without Air Sweep sensors, a fine adjustment sensor bracket, a splice table with tape dispenser and rollers with rubber cork tape.

General

Input voltage range	-	24 VDC nominal 18–30 VDC min/max Proper earth grounding is required. Note that the negative supply and housing ground are interconnected. The power supply must have an SELV output, such as Puls CS10.241–S1, or equivalent.
Current	-	7.8 A maximum
Internal fuse	-	10 A, slow-blow
Operating ambient	-	0° to 50°C [32° to 122°F]
Dimensions	-	Height – 274.5 mm [10.81"] maximum Width – 940 mm [37.01"] maximum 1096.5 mm [43.16"] with splice table Depth – 600 mm [23.62"] not including sensors
Guide weight	-	See table on page 3–2.
Maximum web tension	-	1000 N [250 lbs]
Motor	-	24 VDC Brushless

Certifications and environmental compatibility

Product certifications	-	CE TUV Rheinland of North America to UL61010-1 and CAN/CSA–C22.2 No. 61010-1 and CB Certificate to IEC61010-1
Protection class	-	IP 54 (applies only when all connectors are mated)

Inputs and outputs

Sensor input (2)	- Max Input ± 20 mA
Individually programmable	- 0 to 10 mA (preferred)
Digital port	- Six digital Inputs, active high Low level: 0 to 0.9 V High level: 3.6 to 24 V
	- Four outputs, open collector 55 mA at 1.6 V saturation Maximum +30 VDC applied to output +12 V available to port for input reference
Supply to accessories	- +12 V $\pm 5\%$, 600 mA - -12 V $\pm 5\%$, 80 mA

Maximum cable lengths

Power cable (18 AWG)	- 15 m (50 ft) suggested. (Longer cables may be used if the voltage at the FIFE-500-XL is verified to be within the required 18-30 VDC input range). The suggested maximum length is 20 m (65 ft).
Sensors	- 50 m (165 ft)
Digital input/output port	- 50 m (165 ft)
RGPC-50/F	- 100 m (330 ft)
Operator interface	- 20 m (67 ft)

Service requests and replacement parts

To request service or to get replacement parts, contact one of the following addresses:

Maxcess Oklahoma

222 West Memorial Rd.
Oklahoma City, OK, 73114, USA
Phone: 1.405.755.1600
Fax: 1.405.755.8425
Web: www.maxcessintl.com

Maxcess Europe

Max-Planck-Strasse 8
65779 Kelkheim
Deutschland
Telefon: +49.6195.7002.0
Fax: +49.6195.7002.933
Web: www.maxcess.eu



When ordering replacement parts, please indicate, where possible, part number, drawing number and model description.

If it is necessary to return the FIFE-500-XL for service, care must be taken to properly package the unit to prevent damage during shipment. If possible, use the original shipping containers.



AMERICAS
Tel +1.405.755.1600
Fax +1.405.755.8425
sales@maxcessintl.com
www.maxcessintl.com

EUROPE, MIDDLE EAST
AND AFRICA
Tel +49.6195.7002.0
Fax +49.6195.7002.933
sales@maxcess.eu
www.maxcess.eu

CHINA
Tel +86.756.881.9398
Fax +86.756.881.9393
info@maxcessintl.com.cn
www.maxcessintl.com.cn

INDIA
Tel +91.22.27602633
Fax +91.22.27602634
india@maxcessintl.com
www.maxcess.in

JAPAN
Tel +81.43.421.1622
Fax +81.43.421.2895
japan@maxcessintl.com
www.maxcess.jp

KOREA, TAIWAN,
AND SE ASIA
asia@maxcessintl.com
www.maxcess.asia