

**SYMAT 25 OFFSET PIVOT GUIDE
INSTALLATION SPECIFICATIONS**

The Symat 25 OPG is a displacement type guide which provides web position correction with minimum entry and exit span requirements.

1. Install the Symat 25 Offset Pivot Guide in the process line such that the rollers, when in the neutral position, are parallel to the entry and exit rollers.
2. The Symat 25 must be installed on a flat, machined surface that is flat within .020 TIR.

3. Ensure that the WEB DIRECTION ARROW on the guide is pointed in the direction of web travel.
4. See *Figure Sheet 1-558, Offset Pivot Guide Installation* for factors to consider on where and how to install the Symat 25 Offset Pivot Guide for the best guiding results.

VARIABLES:

ROLLER DIA = 2.00

F = 6.30, 7.88, 9.84

L = 6.30 thru 9.84

J = (0.05 x L) + 0.39

T = Tension

V = Velocity

Tmax = 34.0 lbs for 'S' wrap styles

Tmax = 45.0 lbs for other wrap styles

Vmot = 1.77 (in./sec.)

Vcorr = J x 3 (in./sec.)

Weight = 11.0 lbs Maximum

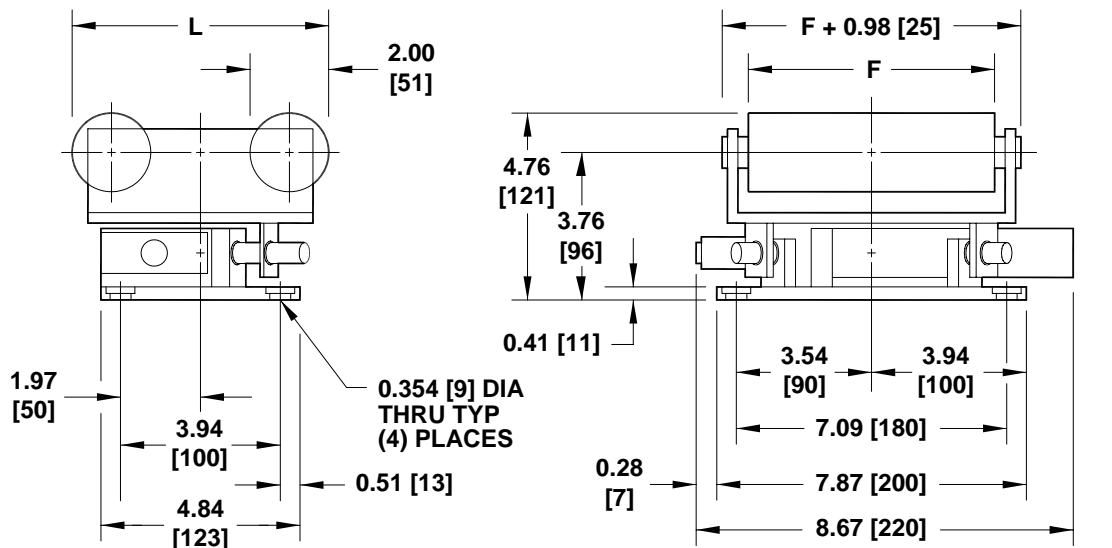

Figure 1.
SYMAT 25 OFFSET PIVOT GUIDE



MAXCESS INTERNATIONAL COMPANIES



GUIDING · INSPECTION



TENSION CONTROL



SLITTING · WINDING

FIFE CORPORATION

222 W. Memorial Road, Oklahoma City, OK 73114-2317, USA / Post Office Box 26508, Oklahoma City, OK 73126-0508, USA
Phone: 405.755.1600 / 800.639.3433 / Fax: 405.755.8425 / E-mail: fife@fife.com / Web: www.fife.com