

FORCE5 LIGHTWEIGHT AIR CHUCKS

MAXCESS

MAGPOWR



TIDLAND

Tidland Force5 Air Chucks are an affordable, lightweight alternative to aluminum chucks, providing reliable non-slip grip for maximum roll control in a wide range of applications. These innovative chucks feature specially-engineered polymer expanding element that not only delivers high durability in extreme conditions, but also enables the chuck to retain its shape over time for ease of insertion and removal. When paired with Tidland's Ultrashaft composite air shafts or composite mandrels, you can safely change rolls from 76 mm (3 inches) to 152 mm (6 inches) ID Cores.



GENERAL SPECIFICATIONS

TORQUE VALUES*

Pressure	Maximum per Chuck
50 psi	3,947 inch-lb
60 psi	4,790 inch-lb
70 psi	5,628 inch-lb
80 psi	6,462 inch-lb
90 psi	7,295 inch-lb

* Torque values are based on ± 5 psi working pressure, core tolerance of 0.05 inch, and a static coefficient of friction between the fiber core and tire of 0.64.

MAXIMUM ROLL WEIGHT

Per Chuck	1,500 lbs	680 Kg
Per Roll	3,000 lbs	1,361 Kg

SHAFT SIZE

	Maximum		Minimum	
Round (diameter)	77.8 mm	3 1/16 inches	25.4 mm	1 inch
Square (on a side)	44.5 mm	1 3/4 inches		
Square (corner to corner)	62.7 mm	2.47 inches		

KEY FEATURES

- Lightest weight air chuck available
- Delivers maximum gripping force during emergency stops and high-torque applications
- Durable polymer expanding element provides long-lasting, reliable operation
- Easy core insertion and removal
- Affordable alternative to aluminum chucks

FORCE5 LIGHTWEIGHT AIR CHUCKS

Specifications

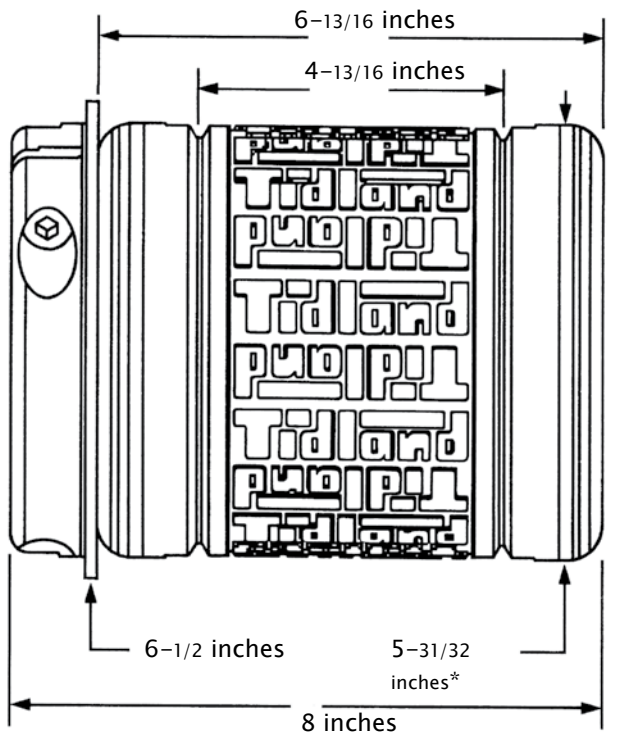
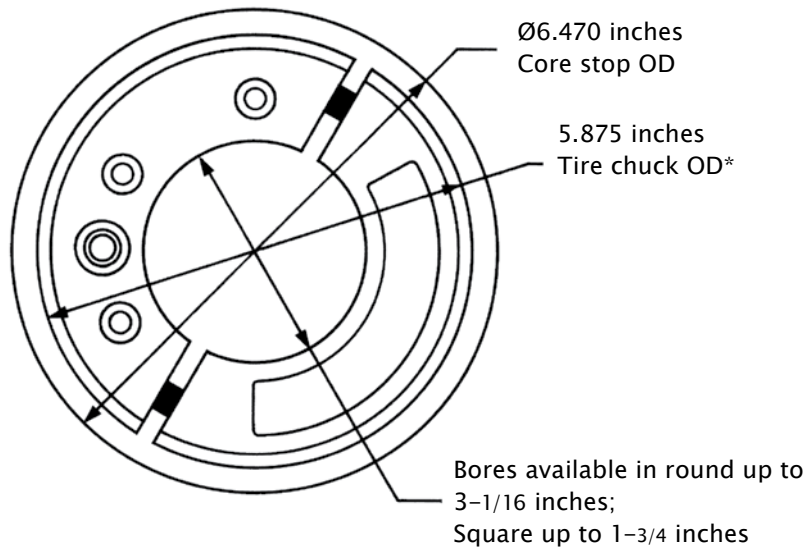

*FOR 6 inch ID. CORES

Complementary Products:

TIDLAND

- Slitting Products & Systems
- Performance Series Knifeholders
- Winding Products
- Ultra Lightweight Air Shafts
- Mark II Roll Saver

FIFE

- Guiding Products & Systems
- Visual & Video Web Inspection

MAGPOWR

- Tension Control Products
- Torque Control Products

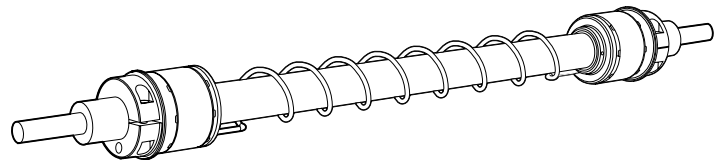

MAXCESS

MAGPOWR



TIDLAND

NORTH AMERICA

Toll Free 800.426.1000
Tel +1.360.834.2345
Fax +1.360.834.5865
sales@maxcessintl.com
www.maxcessintl.com

SOUTH AMERICA

Tel +55.11.3959.0990
Fax +55.11.3856.0990
southamerica@maxcessintl.com
www.maxcessintl.com.br

EUROPE

Tel +49.6195.7002.0
Fax +49.6195.7002.933
sales@maxcess.eu
www.maxcess.eu

INDIA

Tel +91.22.27602633
Fax +91.22.27602634
india@maxcessintl.com
www.maxcess.in

CHINA

Tel +86.756.881.9398
Fax +86.756.881.9393
info@maxcessintl.com.cn
www.maxcessintl.com.cn

JAPAN

Tel +81.43.421.1622
Fax +81.43.421.2895
japan@maxcessintl.com
www.maxcess.jp

KOREA, TAIWAN AND SE ASIA

Tel +65.9620.3883
Fax +65.6235.4818
asia@maxcessintl.com