



FIFE

FIFE-500 MAX WEB GUIDING SYSTEM



A MAXCESS BRAND

Accuracy Perfected

Introducing the FIFE-500 MAX, the next-generation of web guiding from Fife, the industry leader who invented the web guide.

The FIFE-500 MAX takes all of the features customers loved from the FIFE-500 and maximizes everything! With added networking and communications, an intuitive 5 inch color touchscreen, 8 pole motor for smoother guiding, greater accuracy and reduced scrap, the FIFE-500 MAX leverages the latest technology at an attainable price point to improve performance and reduce maintenance. Utilizing brushless motors and even faster processing speeds allows the FIFE-500 MAX to quickly adapt to changes in the web, even at high line speeds.

NEW- Now available for web widths up to 1200 mm and tensions up to 800 N.

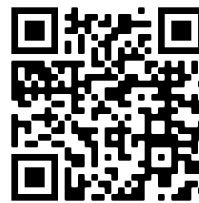
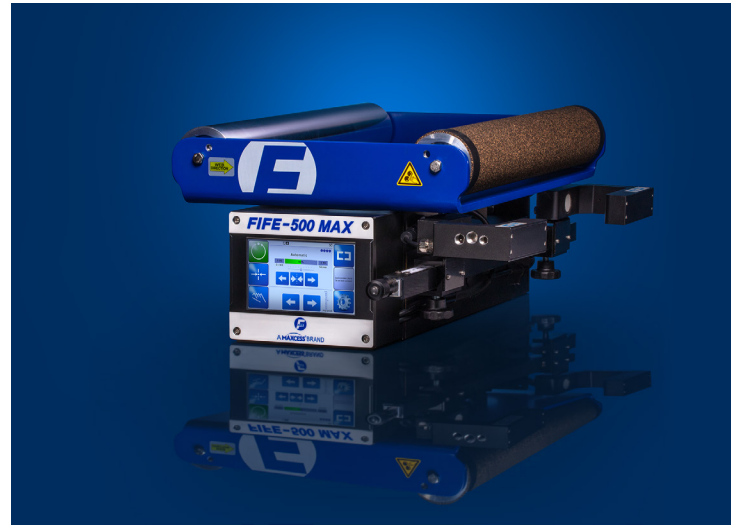

SEE IT IN ACTION!

[CLICK OR SCAN TO WATCH SHORT VIDEO](#)

Key Features & General Specifications



- **Embedded communications-** Ethernet/IP, CC-Link, ModBus TCP (add on option for PROFINET, EtherCAT)
- **Up to 10X better guiding accuracy than the competition**
- **Intuitive 5" color touchscreen**
- **Multiple languages for quick setup and operation, with minimal training needed**
- **8-pole, brushless motor for smoother guiding and reduced scrap**
- **Easy connection to your PLC**
- **Optional splice table and fine adjustment mounting bracket**
- **Compact design fits easily in tight spaces**

Roll Face:

Up to 1200 mm (47.2 inches)

Maximum Tension:

800 N (180 lbs)

Languages:

14 languages

Guide Spans:

Up to 600 mm (23.6 inches)

IP Protection Class:

IP64- Standard

IP65- Optional

Temperature:

0-60° C (32-140° F)

FIFE-500 MAX (400N) DIMENSIONS

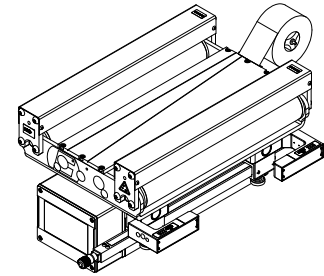
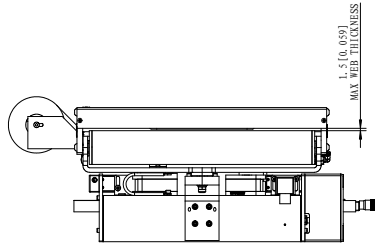
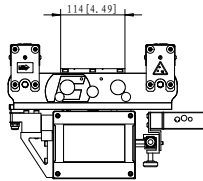
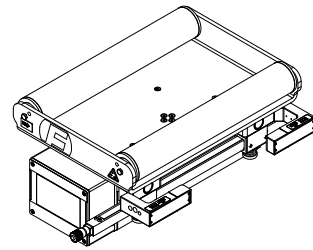
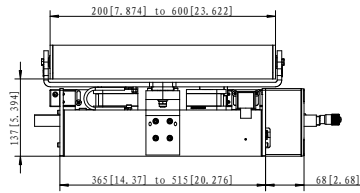
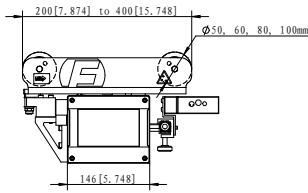

FIFE-500 MAX (800N) DIMENSIONS

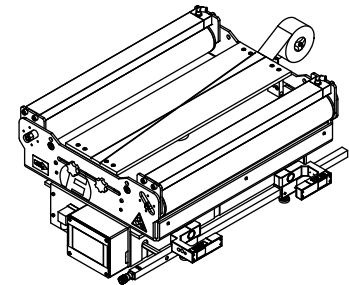
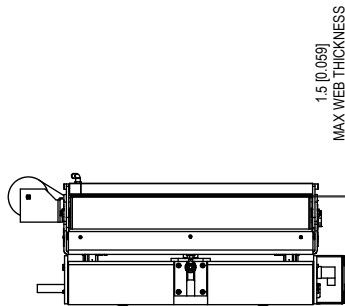
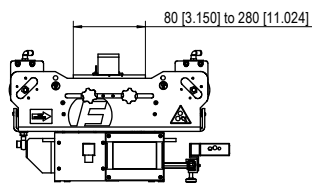
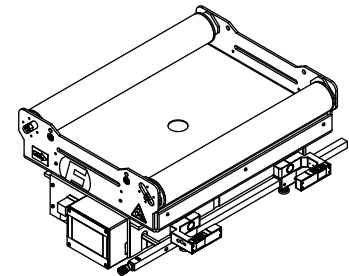
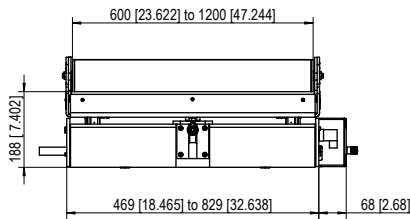
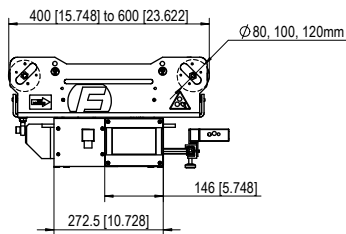

GLOBAL HEADQUARTERS
& AMERICAS

P +1-844-MAXCESS
F +1-405-755-8425
sales@maxcessintl.com

maxcess.com

EUROPE
& MIDDLE EAST

P +49-6195-7002-0
F +49-6195-7002-933
sales@maxcess.eu

maxcess.eu

ASIA
PACIFIC

P +86-400-830-1898
asia.sales@maxcessintl.com

maxcess.com



RELATED PRODUCTS
ASK US ABOUT:

Rotometrics Flexible Dies
MAGPOWR Cygnus
Componex AV Idler Rolls

