

MAXCESS

MAGPOWR

FIFE

TIDLAND

The sensor SE-42 uses modulated infrared light. Its light weight, small size, and insensitivity to ambient light make it ideal for most web guiding applications.

The SE-42 Infrared Sensor measures the lateral position of the guided material photoelectrically. The control range (proportional band) is 17 mm, allowing significant guide point adjustment. The SE-42 is often used in pairs for center guiding when web width variations are limited. The SE-42 sensor can be used to guide either opaque or transparent material.

Fife offers a wide variety of sensor mountings and positioning assemblies for use with the SE-42 infrared sensor. Depending on the application, standard or custom designed mounting brackets can be provided to ensure quick and easy installations.

The SE-42 can be used with any of our applicable guiding systems or as a retrofit / upgrade for existing systems.

The SE-42 can be connected to all available Fife web guide controllers.



GENERAL SPECIFICATIONS

Weight:

130g

Operating temperature:

0° - 60°C

Protection class:

IP40

Power supply:

10 to 15V

Output signal:

0 to 10 mA

Linearity:

5% maximum error (at 10% to 90% of signal)

Plane change:

5% maximum error (at 10% to 90% of gap width)

Temperature drift:

2% maximum error

ESD protected:

designed to IEC 801-2

Ambient light compensated:

Modulated light source

KEY FEATURES

- 17 mm proportional band
- Insensitive to ambient light
- Insensitive to electrostatic discharge
- Temperature stabilized
- Low power consumption
- Small and lightweight
- Option: available with air sweep connection, to keep the sensor field of view clean in dusty environments

INFRARED LIGHT SENSOR

DIMENSIONS

- 1 Infrared light receiver
- 2 Infrared light source
- 3 Sensor field of view
- 4 Connection cable
- 5 Air supply (option)

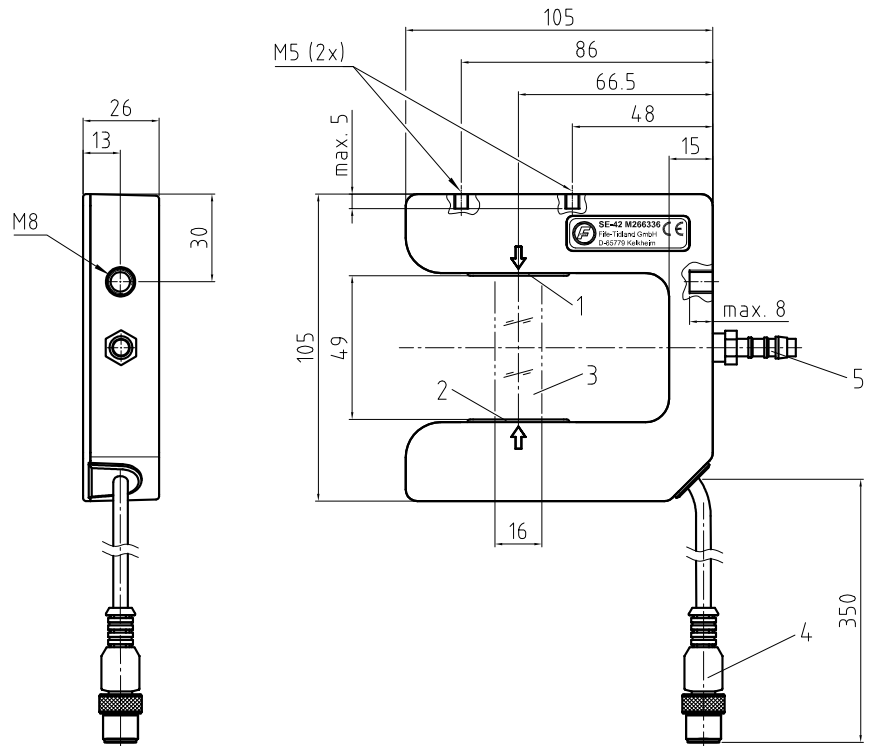

SENSOR MOUNTING

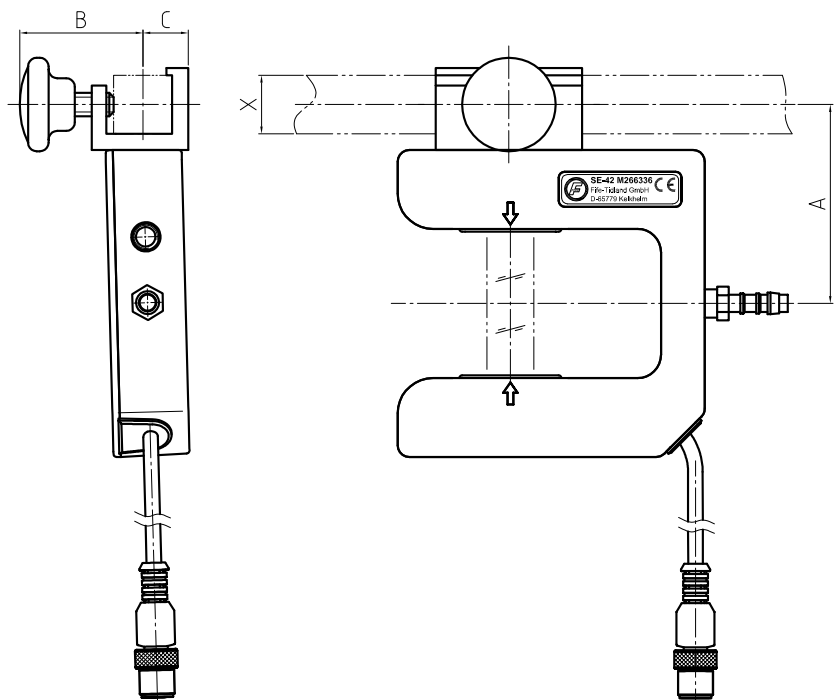

SENSOR MOUNTING	X SQUARE BAR	A	B	C
MB-20	□ 20	68	42,5	15,5
MB-25	□ 25	71	46,5	18,5
MB-32	□ 32	76	51,5	23,5

Dimension shown in mm.

MAXCESS

MAGPOWR



TIDLAND

EUROPE, MIDDLE EAST AND AFRICA

Tel +49.6195.7002.0
 Fax +49.6195.7002.933
 sales@maxcess.eu
 www.maxcess.eu

INDIA

Tel +91.22.27602633
 Fax +91.22.27602634
 india@maxcessintl.com
 www.maxcess.in

NORTH, CENTRAL AND SOUTH AMERICA

Tel +1.405.755.1600
 Fax +1.405.755.8425
 sales@maxcessintl.com
 www.maxcessintl.com

JAPAN

Tel +81.43.421.1622
 Fax +81.43.421.2895
 japan@maxcessintl.com
 www.maxcess.jp

CHINA

Tel +86.756.881.9398
 Fax +86.756.881.9393
 info@maxcessintl.com.cn
 www.maxcessintl.com.cn

KOREA, TAIWAN AND SE ASIA

Tel +65.9620.3883
 Fax +65.6235.4818
 asia@maxcessintl.com