



Thanks to its compact dimensions, it can be integrated in any narrow press, new or existing. It is easy to install and use. The Fife VEO 600 video system matches all the requirements of any application requiring web viewing and manual positioning of the camera.

The LED strobe lamp, integrated in the camera, evenly illuminates the field of view. Synchronization with the printing speed is achieved through a proximity sensor (standard), encoder or mark reading sensor. The current image is displayed on the monitor and refreshed up to 10 times per second. The operator can visually inspect the quality, register and all other parameters during the printing process. To inspect small details, the Fife VEO 600 camera has a 10:1 optical zoom. The “Auto-Scroll” (to scroll through the entire print repeat length) and “Split-Screen” (comparison between a reference image and the current one) are also available.

These functions combined with the excellent price-performance ratio, make the Fife 600 video inspection system the ideal solution for narrow web printing presses.

GENERAL SPECIFICATIONS

Model

VEO 600-R:
Manual positioning with keypad
on remote

Field of View

90 x 75.5 mm

Optical Zoom

10x

Enclosures

IP20

Ambient Temperature

0 to 40°C

Power Supply

110 to 240VAC (50 to 60Hz)

System synchronisation

Image recording frequency:
10 images per second, max.

Strobe: LED

Positioner

Manual Positioning:
– Dual mount max. length: 3 m
– Cantilevered mount max.
length: 0,80 m

User Interface

Remote Keypad

KEY FEATURES

- Cost-efficient
- Easy to operate
- Installs quickly (one cable from camera)
- Dual mount or cantilevered mount
- Split-screen, image freeze and rotation
- Timing inputs include gear-tooth sensor, encoder, eye-mark sensor and external synchronization inputs
- Dual monitor available
- Gamma adjustment
- Auto-Scroll Function

VEO 600 VIDEO ENHANCED OBSERVATION

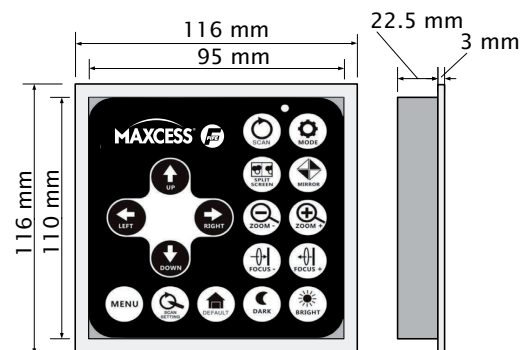
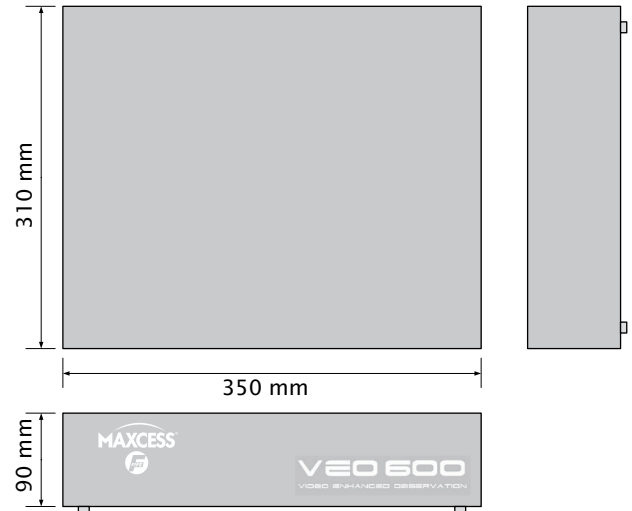
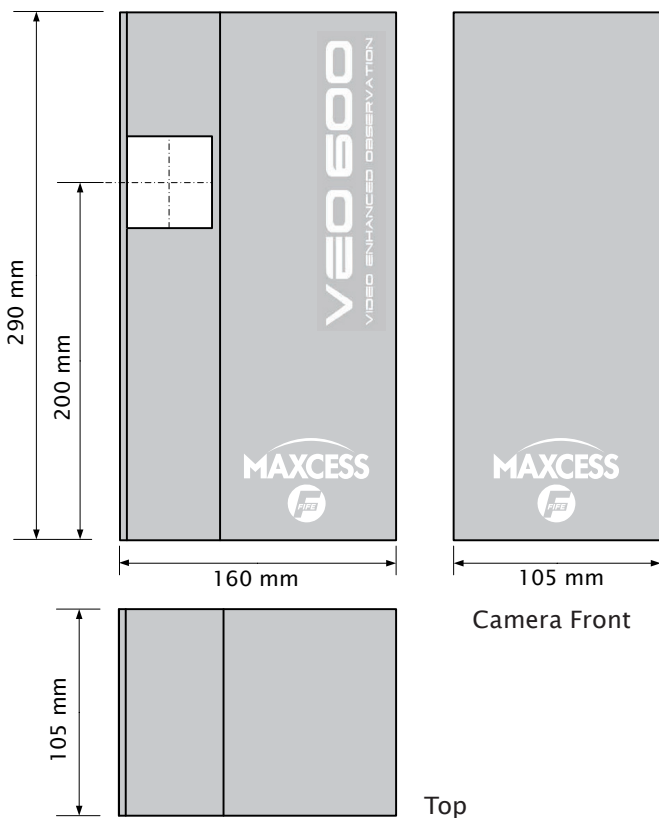
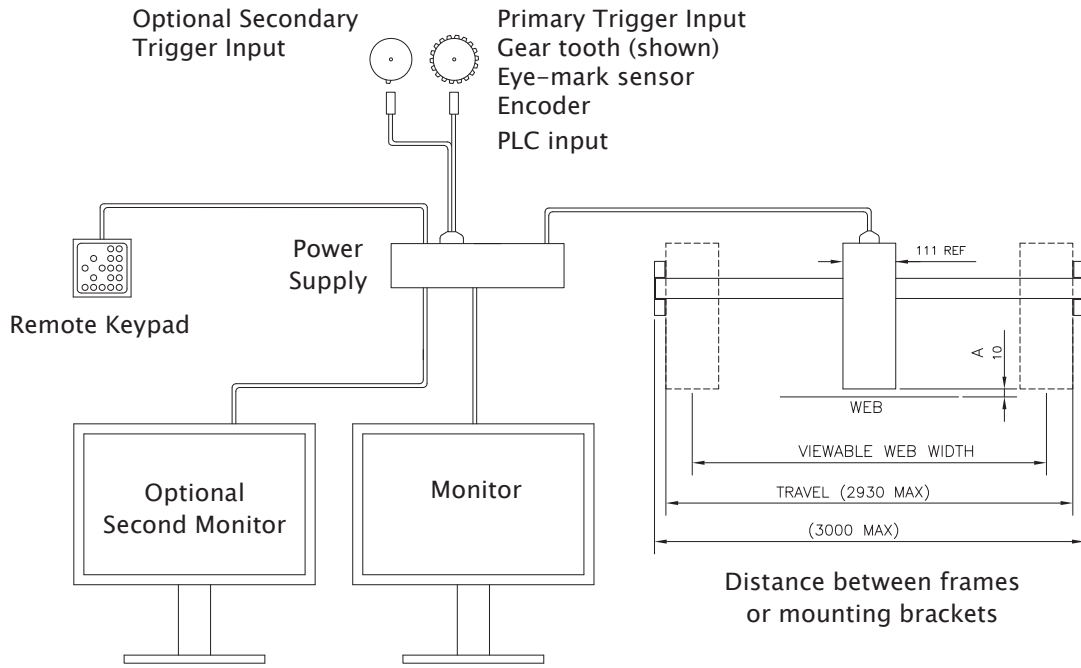

EUROPE, MIDDLE EAST AND AFRICA
 Tel +49.6195.7002.0
 sales@maxcess.eu
 www.maxcess.eu

NORTH, CENTRAL AND SOUTH AMERICA
 Tel +1.405.755.1600
 sales@maxcessintl.com
 www.maxcessintl.com

CHINA
 Tel +86.756.881.9398
 info@maxcessintl.com.cn
 www.maxcessintl.com.cn

JAPAN
 Tel +81.43.421.1622
 japan@maxcessintl.com
 www.maxcess.jp

INDIA
 Tel +91.22.27602633
 india@maxcessintl.com
 www.maxcess.in

