

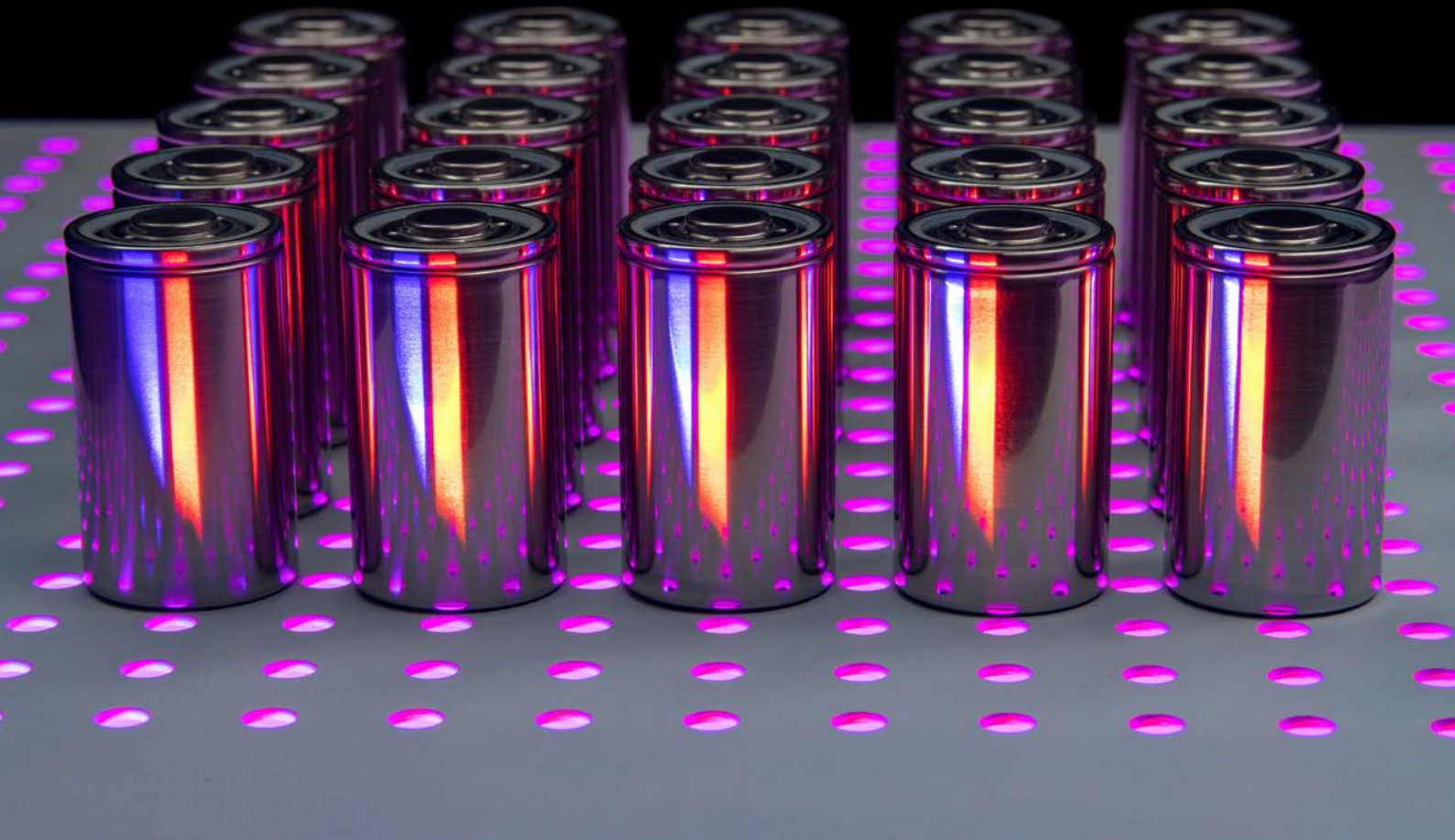

SOLUTIONS FOR BATTERY MANUFACTURING



# Web Handling Solutions For Battery

Guiding, Vision Systems, Winding, Slitting, Tension Control,  
Rotary Dies and Precision Rolls

# Our Battery Experts Keep You Running Better, Faster and Smarter

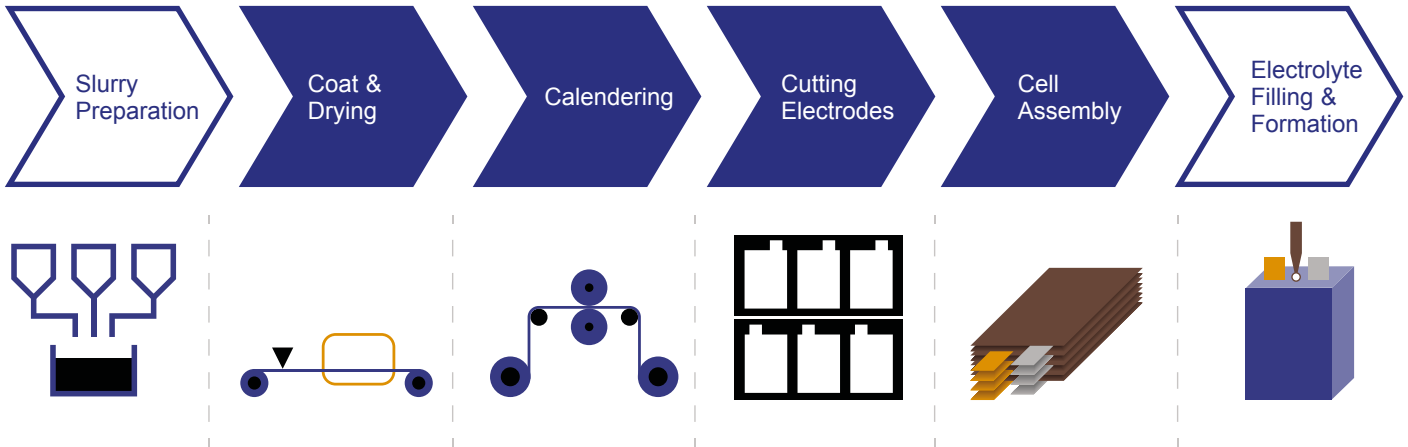

## Battery Manufacturing Applications With Maxcess Solutions

When it comes to Lithium-Ion battery manufacturing, precision is paramount. Only Maxcess provides end-to-end knowledge, ease of installation and decades of expertise for manufacturing Lithium-Ion batteries. We've been involved since the beginning of battery web manufacturing, and we are consistently investing in cutting-edge Industry 4.0 solutions for the future.

Whether you're coating, laminating, slitting, rewinding, notching or calendering your battery web, we have solutions!

With our RotoMetrics, Fife, Tidland, MAGPOWR, Webex, Valley Roller, Componex and Maxcess Vision Systems brands, Maxcess has the end-to-end solutions to ensure you deliver quality end product while minimizing scrap, waste and downtime. Our products are engineered with the ultimate precision and quality in mind, it's in our DNA.

In addition, with a global team of service and technical support associates around the world, you can be confident in our ability to serve you after the sale. No matter where you are, we will be there 24/7 to support you.

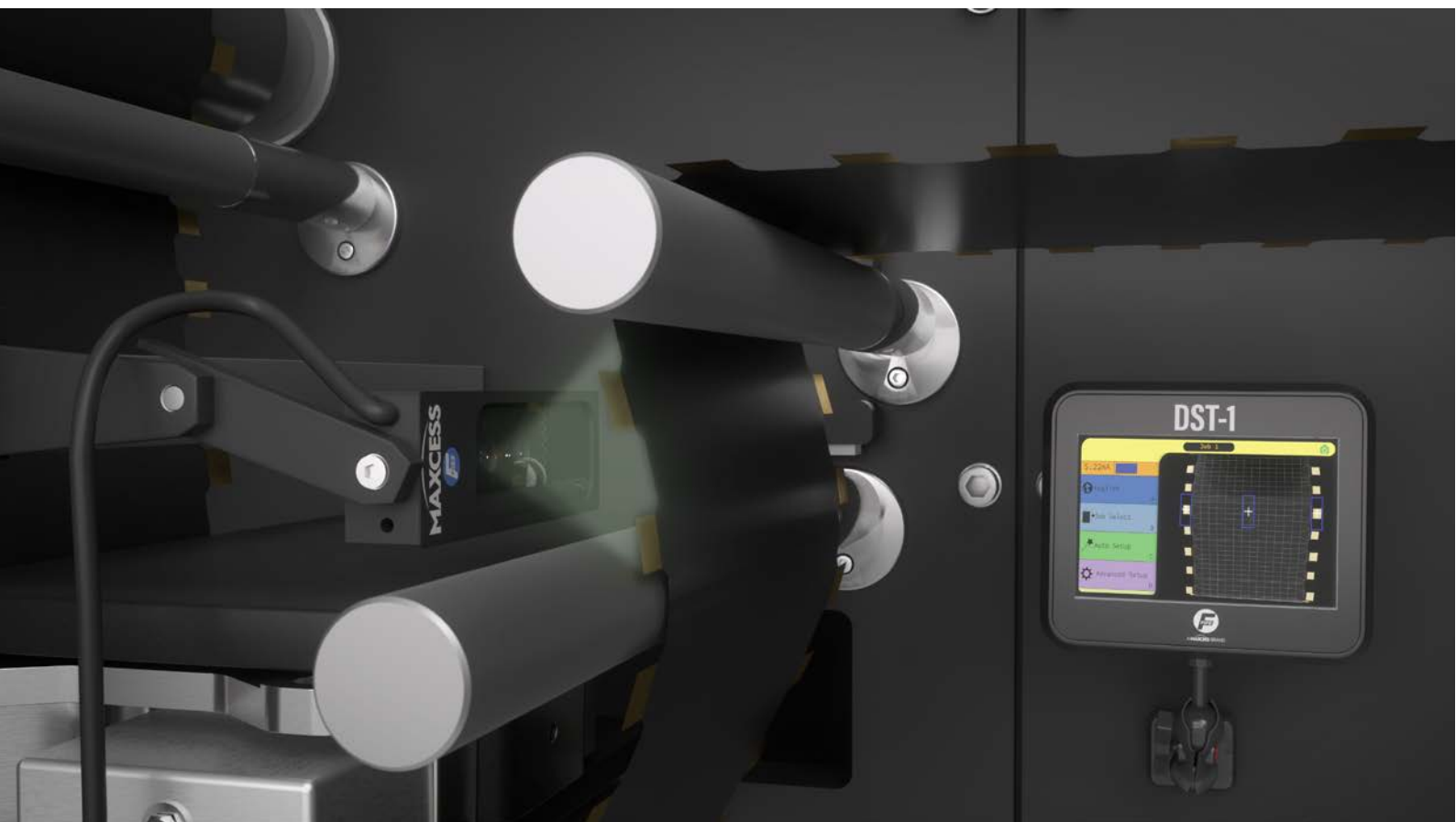

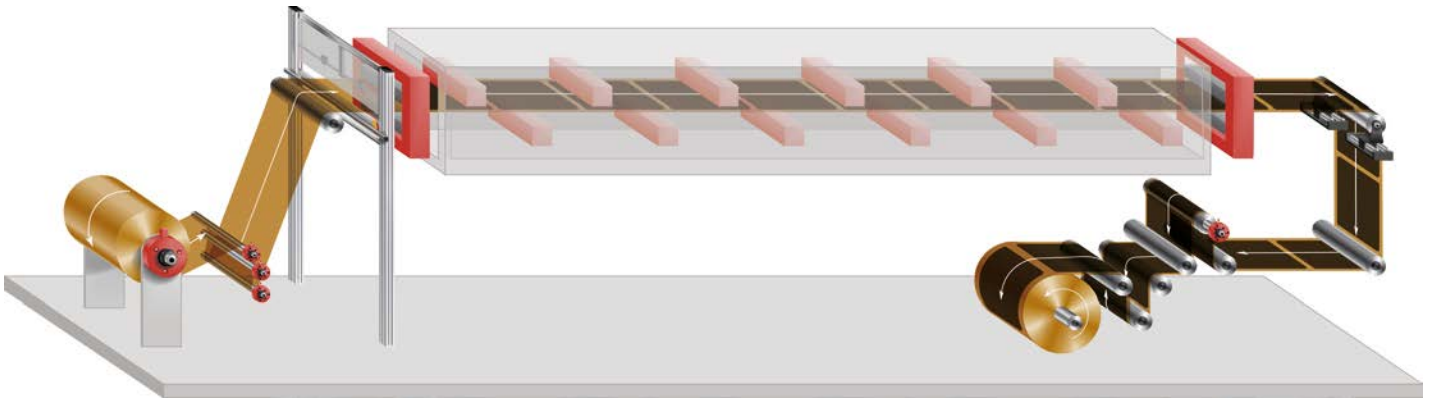

## Fife Symat Offset Pivot Guide

When space is limited, Fife Offset Pivot Guides deliver web/strip position correction with minimal entry and exit span requirements. This type of guide is typically furnished with two rollers. The entire guide pivots to control web position and minimize web stress. We have a wide range of offset pivot guides that will meet or exceed your application specification requirements.

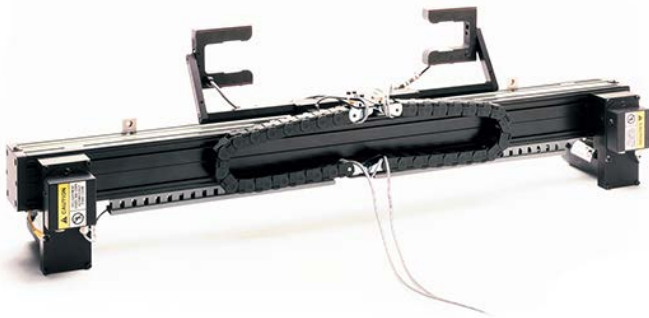

## Fife Digital Sensors

We offer industry-leading sensors that are ideal for your battery manufacturing line.

**Digital Series Sensors-** we offer a complete line of Infrared and Ultrasonic sensors that are tailor-made for your application while requiring no setup with our digital controllers.

**DSE-45 Wideband-** an ultrasonic sensor, the DSE-45 allows you to track up to 16 web edges or 8 webs at the same time

**DSE-17 Wideband-** an infrared sensor, the DSE-17 tracks up to four independent web edges simultaneously, with no opacity set up required.



## Fife Pro-Trac Series

Our Pro-Trac sensor positioning systems are robust systems used for automating web width changes in your battery application. Common application uses for the Pro-Trac systems include chasing systems, moving-sensor center guide systems, web width measurement systems, or simple sensor positioning.



## Fife Actuators

Fife electromechanical actuators are designed to be trouble-free with minimal backlash, producing the highest Dynamic Response in the industry, typically less than 0.051 mm (0.002 inch), for higher accuracy and longer product life. Required application thrust will be a function of total load, coefficient of friction and performance requirements.

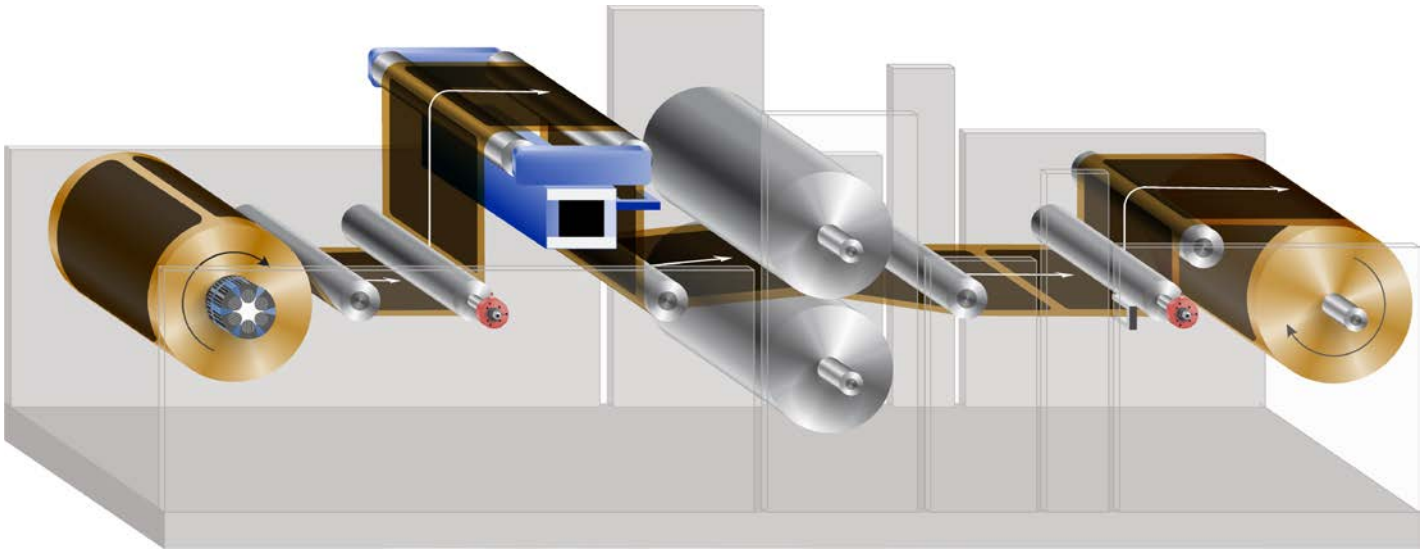

### Fife Smart Actuator

The NEW Smart Actuator series from Fife offer thrust options in 1200N, 2340N, 5,000N and 10,000N of thrust. In addition, you'll notice 30% faster speeds than the competition, with accuracy within 0.05 mm. Featuring a brushless DC motor for reduced maintenance and an easy-to-install platform that uses only three cables, you'll enjoy a robust series of actuators that are powerful, accurate and extremely easy to use.

### Tidland Winding Solutions

At Tidland, we understand that our customers' competitive advantage depends on ever-increasing productivity. For over 65 years, equipment manufacturers and end users in the web handling industry have trusted Tidland to deliver innovative solutions that keep them on the leading edge. Whether you're working with battery films or foils, papers or non-wovens, Tidland offers the broadest portfolio of slitting and winding products and accessories designed to meet your specific requirements.



### Tidland Performance and Control Series Knifeholders

Our robust line of knifeholders are an ideal solution on slitting/rewinding lines when slitting copper film and aluminum film webs. Providing faster setups, increased productivity, safer setups and unrivaled finished roll quality, the revolutionary Performance Series Knifeholder is available in three sizes to accommodate a wide range of slitting materials and web speed, for shear, crush and razor slitting of a wide range of applications. With our 360° blade guard, you can ensure your operator is safe when performing blade changes.

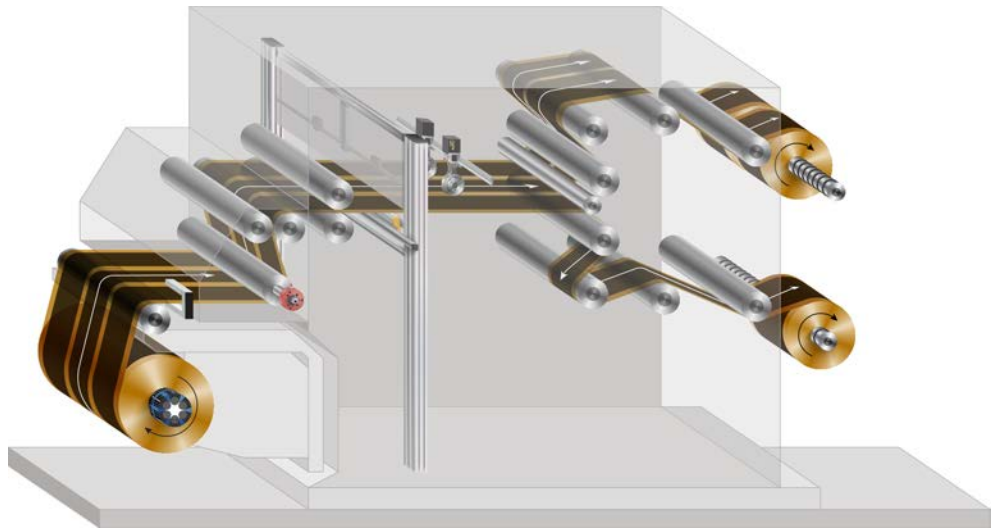

## Tidland Automated Slitting

Combining decades of slitting and engineering knowledge, our automatic slitting positioning systems provide a highly-accurate, safe and reliable solution for your slitting needs. When multiple materials or line changes are frequent, our automated slitting systems quickly return your investment by not requiring an operator to manually reposition each knifeholder with a tape measure, reducing waste while increasing safety by not requiring an operator near the knife zone. In addition, all slitting parameters for a given job can be stored as a recipe, ensuring consistent slitting results with faster setups.

## Maxcess VisionMax and VisionConnect 100% Inspection

**VisionMax** 100% inspection ensures optimal product quality by using high-resolution color cameras for repeating jobs, alerting the operator in real-time of any process issues that will cause returns. With VisionMax you can:

- Inspect while extruding, providing real-time feedback on gel density and black spec contamination
- Inspect while unwinding, preventing holes, dents, edge cracks and splices, which disrupt your process
- Use our inspection system to guarantee your business by shipping product with zero defects



## Maxcess Precision Rolls

We manufacture the most precise precision roll solutions in the industry. We offer:

- Dead shaft idler rolls in aluminum, stainless steel or carbon fiber
- Live shaft idler rolls
- Heat transfer and chill rolls (with electric options)
- Custom coatings and rubber coverings



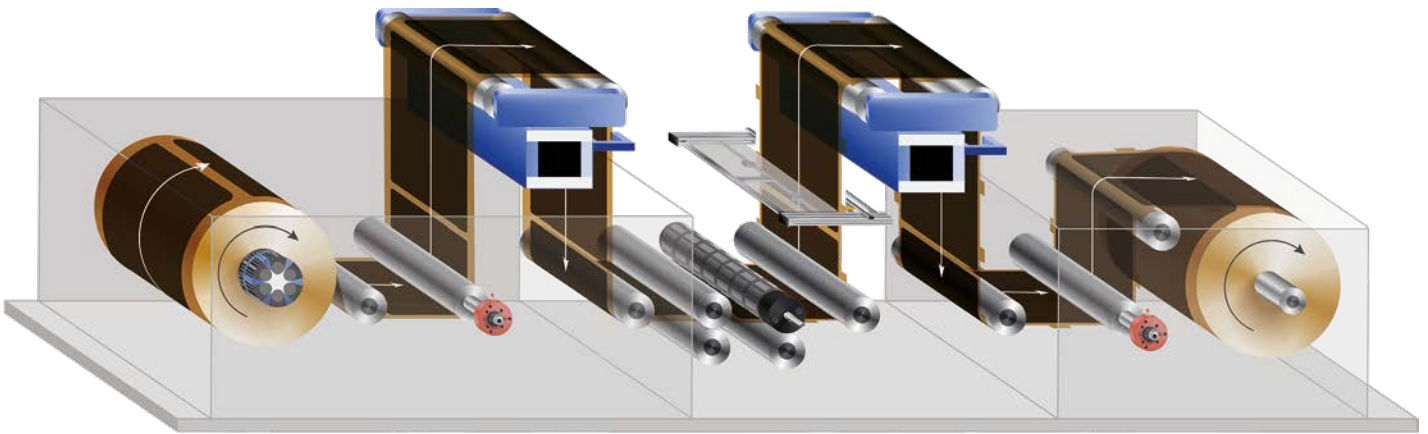

### Fife GuideLine Digital Line Guide Sensor

- Capable of detecting battery tabs as lines, with the ability to then guide to the tabs
- Compatible with the popular D-MAX Enhanced Series Web Guiding System
- Ability to easily guide to lines, edges of lines and graphic patterns on the fly



### Focused Tab Guiding With the DST-1

Guide what the others can't! Ideal for battery guiding applications, the DST-1 Object Recognition Sensor dramatically improves setup time and material changeovers, providing the user with the ability to guide almost any material in three steps. Unlike C shaped sensors, the DST-1 can be placed further from the web, one-sided, with no reflector or light source needed. Ideal for battery applications, the DST-1 can ignore feature like tabs on battery webs, ensuring accuracy of your web guide.

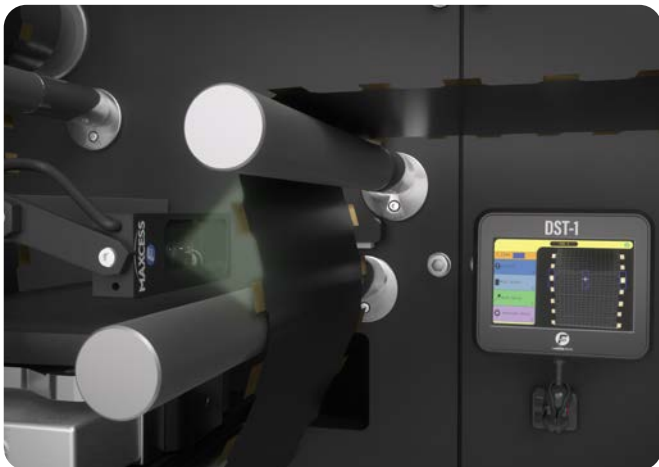

### Fife Web Guiding Solutions

Since 1939, Fife has been at the forefront of web guiding solutions. From our new all-in-one FIFE-500 MAX with advanced networking protocols to our offset pivot and steering guides, we have a web guiding solution that can be expertly engineered to your exacting specifications.



### RotoMetrics Rotary Dies

When it comes to Rotary Die cutting in your notching application, RotoMetrics has decades of expertise, making us a household name in precision die cutting. Our dies are engineered and manufactured at the most exacting tolerances, where we measure precision in microns!

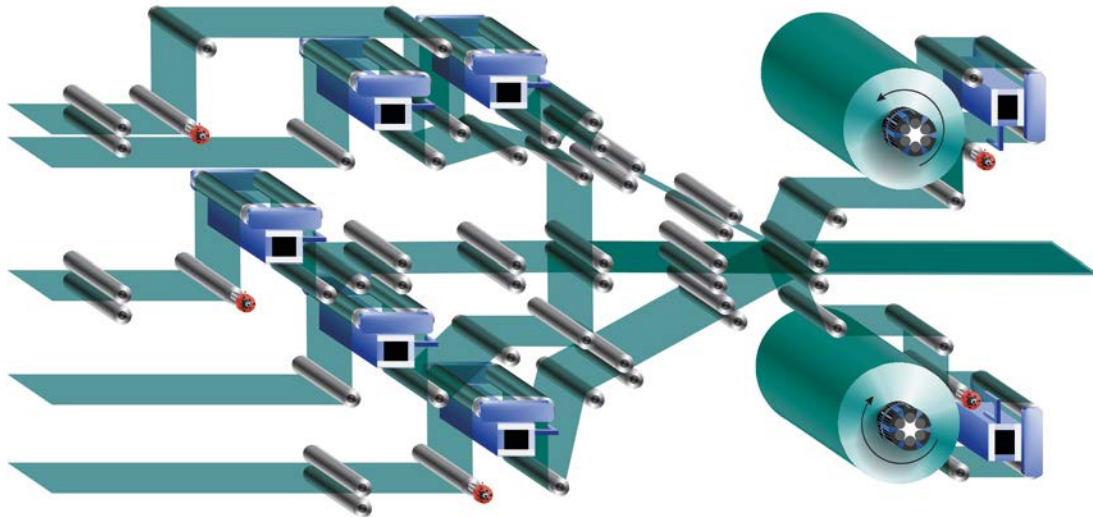

### FIFE-200 Battery Guiding System

The FIFE-200 is a small web guide and controller designed from the ground-up for battery guiding applications. With an IP40 ingress protection rating and four different roll face and guide spans, as well as two different roller diameters, it is ideal for small webs and battery guiding applications.



### MAGPOWR Load Cells

MAGPOWR's TLC Load Cells are extremely accurate devices used to measure web tension in any unwind, rewind or intermediate web processing application. Delivering precise web tension with low temperature drift due to a full Wheatstone bridge construction, the Load Cells allow for force measurement and 10x overload protection in both force directions. With a low profile design, required space between the machine frames dedicated to the Load Cell is minimized.



### Fife D-MAX Enhanced Web Guiding Systems

Introducing the most powerful controller in the industry, the perfect pairing for battery webs. With the D-MAX Enhanced you can:

- Control up to three guides from a single controller
- A complete system of powerful modular components to improve efficiency and roll quality
- AOP for Rockwell Automation™ PACs

### MAGPOWR Tension Amplifiers

Our DLCA and DLCA-NET Digital Load Cell Amplifiers provide powerful and versatile amplification in a compact enclosure that are easy to use, offering weightless Load Cell calibration to ensure quick setup times. DLCA-NET offers advanced networking capabilities to your HMI/PLC.



DLCA-NET Shown

## SOLUTION SUMMARY

	Web Guide Controller	Web Guides	Actuators	Sensors	Sensor Positioners	Slitting Systems	Shafts	Idler Rolls	Heat Transfer/Electric Rollers	Vacuum Rolls	Load Cells	Tension Amplifiers	Tension Controllers	Rotary Dies	Vision Inspection
Coating Lines	✓	✓	✓	✓	✓		✓	✓			✓	✓	✓		✓
Calendering Lines	✓	✓	✓	✓		✓	✓	✓	✓	✓	✓	✓	✓		
Slitting/Rewinding Lines	✓		✓	✓		✓	✓	✓			✓	✓	✓		✓
Notching Lines	✓	✓		✓			✓	✓			✓	✓	✓	✓	✓
Laminating Lines	✓	✓		✓			✓	✓			✓	✓	✓		

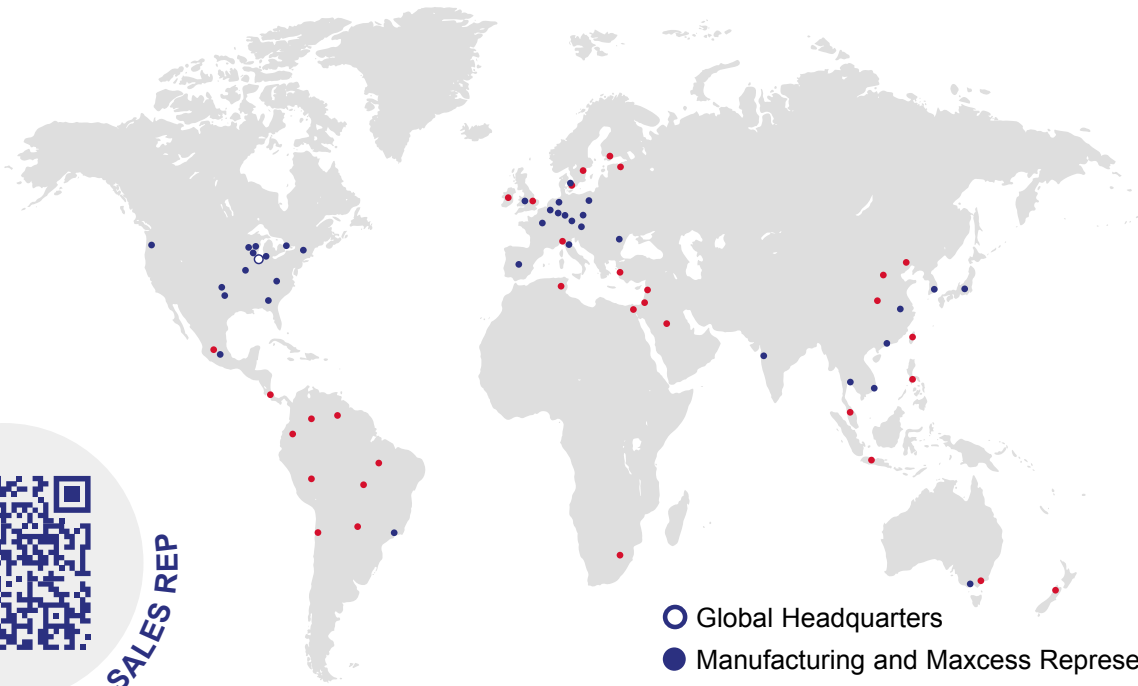

- Global Headquarters
- Manufacturing and Maxcess Representatives
- Sales and Service Agents



Global HQ & Americas

+1-844-MAXCESS

sales@maxcessintl.com

Maxcess Europe HQ  
Fife-Tidland GmbH

+49-6195-7002-0  
sales@maxcess.eu

Maxcess Germany  
RotoMetrics Deutschland GmbH

+49 6134 7262 - 0  
sales@rotometrics.de

Maxcess UK  
RotoMetrics Intl. Ltd.

+44 1922 6100 00  
uk.sales@maxcessintl.com

Web  
maxcess.com

Shop  
mymaxcess.eu  
myroto.com

