

REV	SYM	DESCRIPTION	DATE	BY
V10		RELEASE	2024/06/05	RYAN
V11		DIMENSION UPDATE	2024/12/09	RYAN

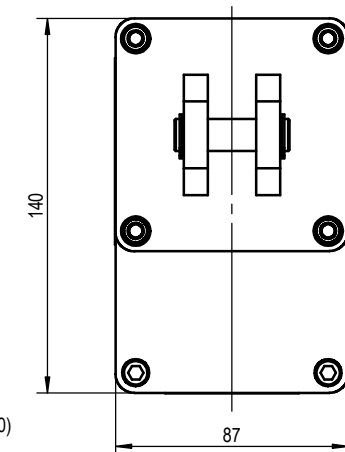

STANDARD STROKES:

THRUST FORCE	STROKE	'A'	'B'
1200N	50	385.9	243.6
	100	460.9	293.6
	125	498.4	318.6
	150	535.9	343.6
	200	610.9	393.6
	250	685.9	443.6
2450N	300	760.9	493.6
	400	910.9	593.6
	50	414.9	272.6
	100	489.9	322.6
	125	527.4	347.6
	150	564.9	372.6
200	639.9	422.6	
250	714.9	472.6	
300	789.9	522.6	
400	939.9	622.6	

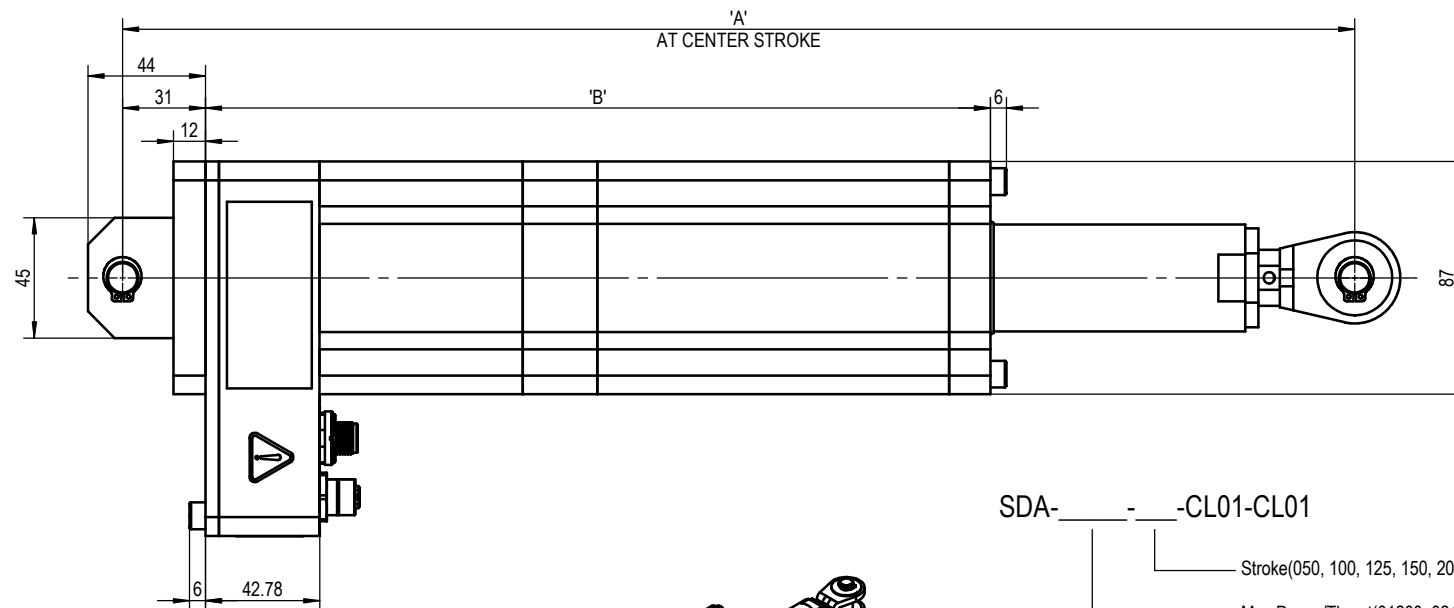

SDA-\_\_\_\_\_-CL01-CL01

Stroke(050, 100, 125, 150, 200, 250, 300, 400)

Max Power/Thrust(01200, 02450)

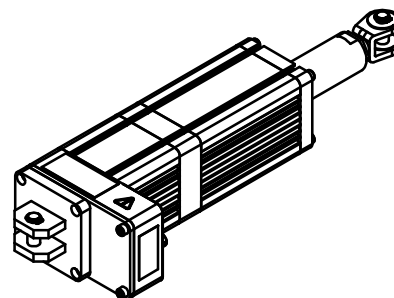

项目号/ PROJECT NUMBER	EU2101	材料/MATERIAL	N/A			
公差除单另外指定 尺寸公差参考 ISO 2768 T1-m, 形位公差参考 ISO 2768 T2-K. Unless otherwise specified. General tolerance refer: ISO 2768 T1-m. Geometrical tolerance refer: ISO 2768 T2-K 除非特别指定, 尺寸单位为 mm. Dimensions are shown in mm. Unless otherwise specified.	表面处理/FINISH	N/A				
	设计/DESIGN	日期/DATE	名称/DESCRIPTION			
RYAN	2024/12/9	SDA-1200/2450N				
审核/APPROVED BY	CLEVIS MOUNT METRIC INSTALLATION DRAWING					
第一角画法/FIRST ANGLE PROJECTION	图纸大小/SIZE	比例/SCALE	图纸编号/DRAWING NO.	版本/REV	页码/PAGE	
	A3	1:2	620001602-001	V11	1/1	

Building 4, No. 4333  
Zuhai Avenue,  
Nanping town,  
Xiangzhou District,  
Zuhai, Guangdong,  
China, 519060.  
www.maxcessintl.com  
400-830-1898

**MAXCESS**  
Maxcess(Zuhai)Industrial Automation Equipment Co.,Ltd

REV	SYM	DESCRIPTION	DATE	BY
V10		RELEASE	2024/06/05	RYAN
V11		DIMENSION UPDATE	2024/12/09	RYAN

STANDARD STROKES:

THRUST FORCE	STROKE	'A'	'B'
1200N	50	388	243.6
	100	463	293.6
	125	500.5	318.6
	150	538	343.6
	200	613	393.6
	250	688	443.6
	300	763	493.6
2450N	400	913	593.6
	50	417	272.6
	100	492	322.6
	125	529.5	347.6
	150	567	372.6
	200	642	422.6
	250	717	472.6
300	792	522.6	
400	942	622.6	

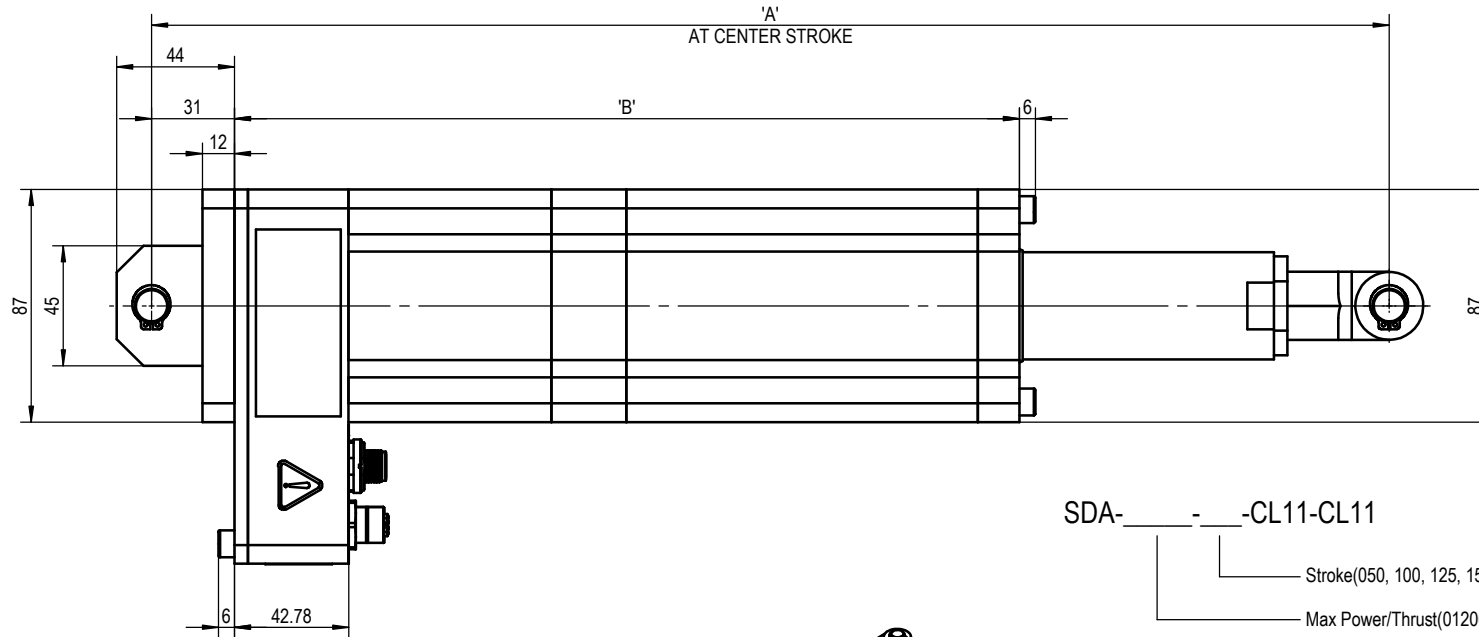
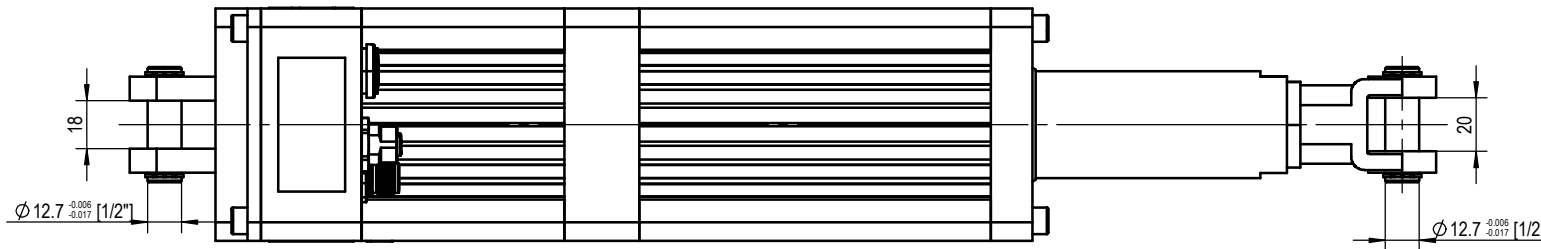

SDA-\_\_\_\_\_ -CL11-CL11

Stroke(050, 100, 125, 150, 200, 250, 300, 400)

Max Power/Thrust(01200, 02450)

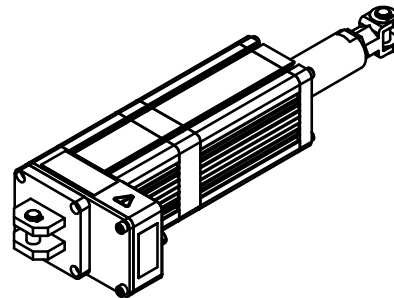
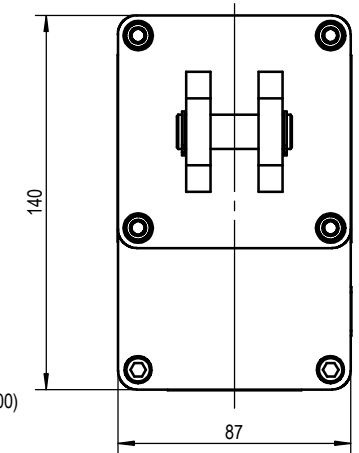

项目号/ PROJECT NUMBER	EU2101	材料/MATERIAL	N/A			
公差除表外指定 尺寸公差参考 ISO 2768 T1-m, 形位公差参考 ISO 2768 T2-K. Unless otherwise specified, General tolerance refer: ISO 2768 T1-m, Geometrical tolerance refer: ISO 2768 T2-K 除非特别指定, 尺寸单位为 mm. Dimensions are shown in mm. Unless otherwise specified.	表面处理/FINISH	N/A				
	设计/DESIGN	日期/DATE	名称/DESCRIPTION			
RYAN	2024/12/9	SDA-1200/2450N				
审核/APPROVED BY	CLEVIS MOUNT INCH INSTALLATION DRAWING					
第一角画法/FIRST ANGLE PROJECTION	图纸大小/SIZE	比例/SCALE	图纸编号/DRAWING NO.	版本/REV	页码/PAGE	
	A3	1:2	620001602-002	V11	1/1	

Building 4, No. 4333  
Zuhai Avenue,  
Nanping town,  
Xiangzhou District,  
Zuhai, Guangdong,  
China, 519060.  
www.maxcessintl.com  
400-830-1898

**MAXCESS**  
Maxcess(Zuhai)Industrial Automation Equipment Co.,Ltd

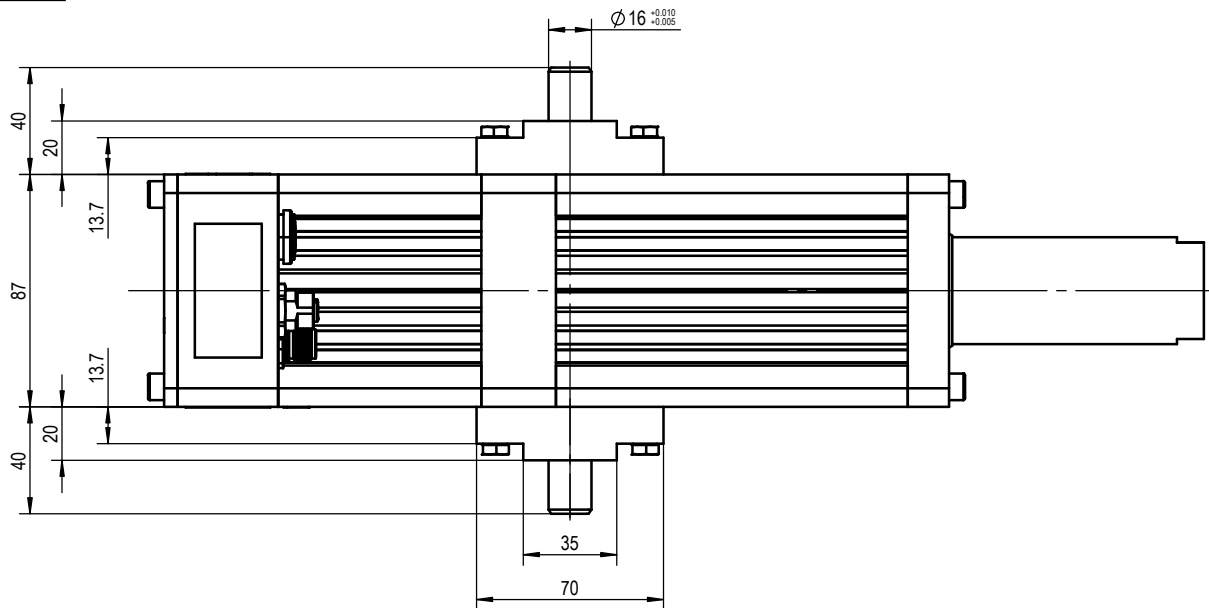

REV	SYM	DESCRIPTION	DATE	BY
V10		RELEASE	2024/06/05	RYAN
V11		DIMENSION UPDATE	2024/12/09	RYAN

STANDARD STROKES:

THRUST FORCE	STROKE	'B'
1200N	50	243.6
	100	293.6
	125	318.6
	150	343.6
	200	393.6
	250	443.6
2450N	300	493.6
	400	593.6
	50	272.6
	100	322.6
	125	347.6
	150	372.6
2450N	200	422.6
	250	472.6
	300	522.6
	400	622.6

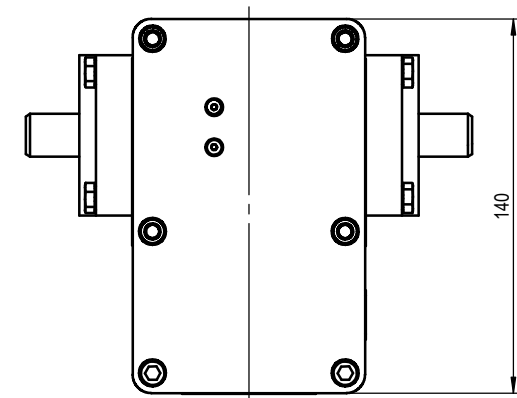
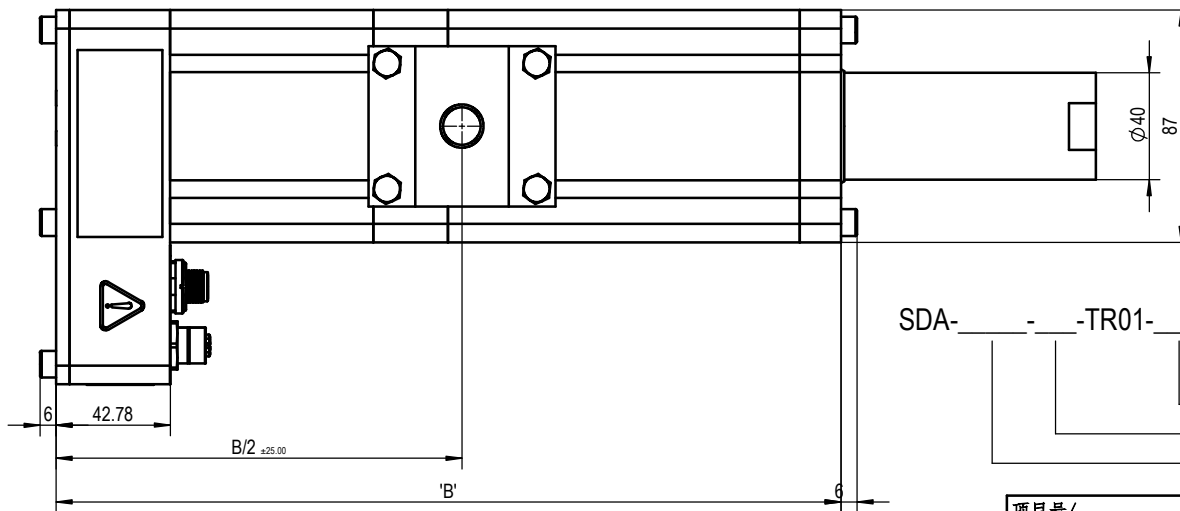

SDA- - -TR01-

Rod End Mounting Type(CL01, CL11, RE01, RE11)  
Stroke(050, 100, 125, 150, 200, 250, 300, 400)  
Max Power/Thrust(01200, 02450)

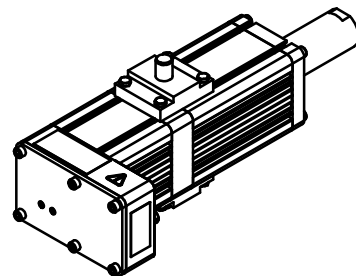

项目号/ PROJECT NUMBER	EU2101	材料/MATERIAL	N/A				
公差除单另外指定 尺寸公差参考 ISO 2768 T1-m, 形位公差参考 ISO 2768 T2-K. Unless otherwise specified. General tolerance refer: ISO 2768 T1-m. Geometrical tolerance refer: ISO 2768 T2-K 除非特别指定。尺寸单位为 mm。 Dimensions are shown in mm. Unless otherwise specified.	表面处理/FINISH	N/A					
设计/DESIGN	日期/DATE	名称/DESCRIPTION	<b>SDA-1200/2450N</b> <b>TRUNNION MOUNT</b> <b>INSTALLATION DRAWING</b>				
RYAN	2024/12/9	审核/APPROVED BY					
This drawing is the property of Maxcess. It is loaned with the understanding that it may not be reproduced nor may the information contained herein be used for the making of drawings or for manufacturing purposes without the written consent of Maxcess.		第一角画法/FIRST ANGLE PROJECTION	图纸大小/SIZE	比例/SCALE	图纸编号/DRAWING NO.	版本/REV	页码/PAGE
			A3	1:2	620001602-003	V11	1/1



Building 4, No. 4333  
Zhuhai Avenue,  
Nanping town,  
Xiangzhou District,  
Zhuhai, Guangdong,  
China, 519060.  
www.maxcessintl.com  
400-830-1898

Maxcess(Zhuhai)Industrial Automation Equipment Co.,Ltd

REV	SYM	DESCRIPTION	DATE	BY
V10		RELEASE	2024/06/05	RYAN
V11		ADD M6 HOLE, DIMENSION UPDATE	2024/12/09	RYAN

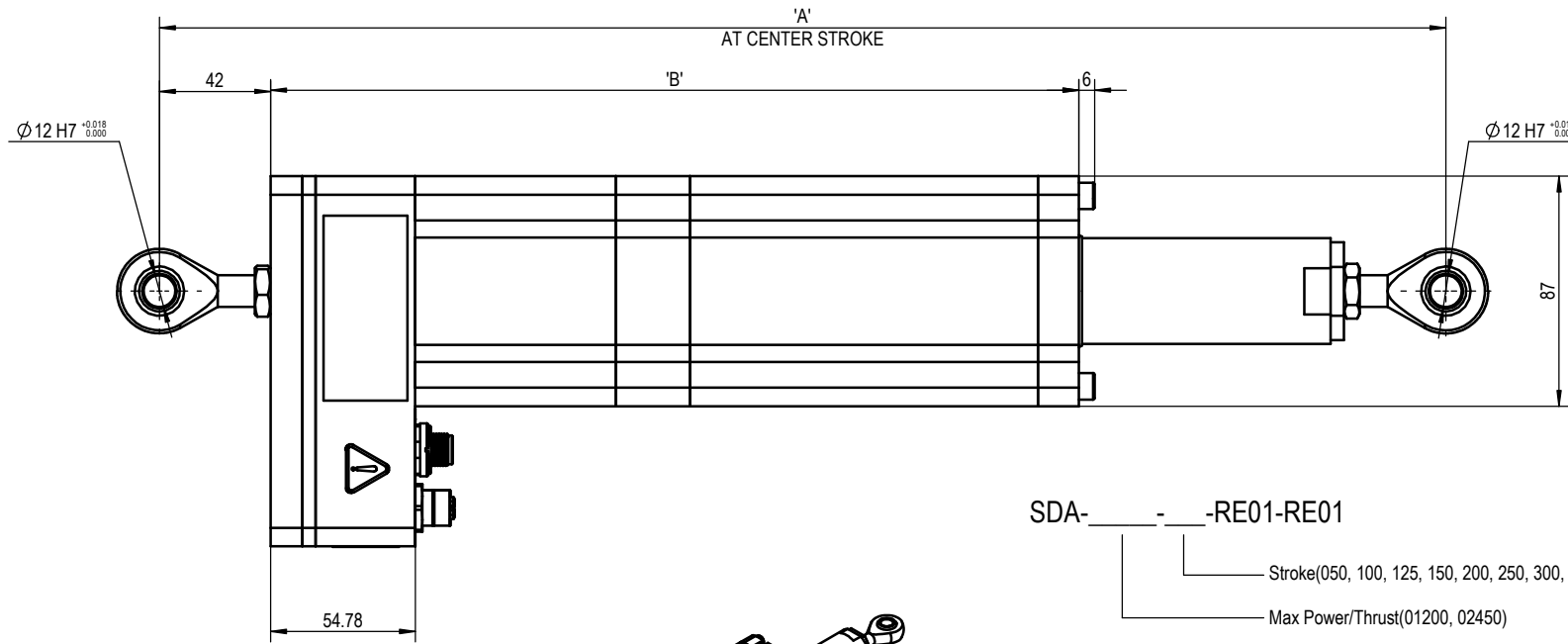
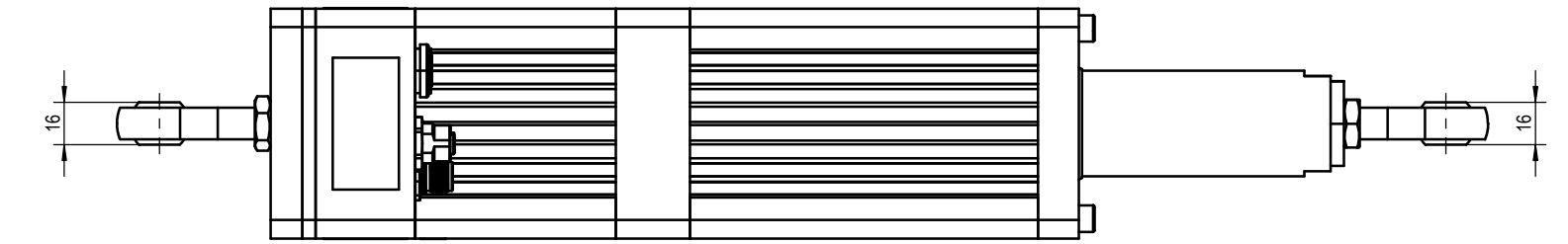

STANDARD STROKES:

THRUST FORCE	STROKE	'A'	'B'
1200N	50	411.4	255.6
	100	486.4	305.6
	125	523.9	330.6
	150	561.4	355.6
	200	636.4	405.6
	250	711.4	455.6
	300	786.4	505.6
2450N	400	936.4	605.6
	50	440.4	284.6
	100	515.4	334.6
	125	552.9	359.6
	150	590.4	384.6
	200	665.4	434.6
	250	740.4	484.6
300	815.4	534.6	
400	965.4	634.6	

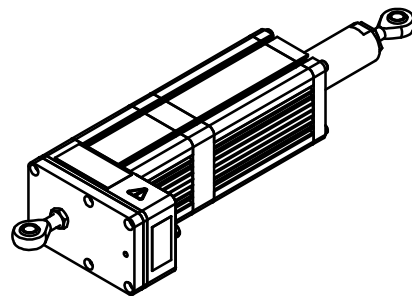
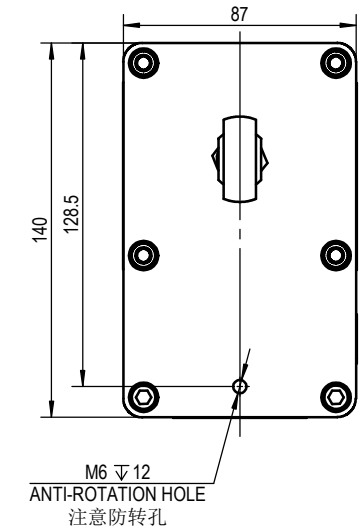

SDA-RE01-RE01

Stroke(050, 100, 125, 150, 200, 250, 300, 400)

Max Power/Thrust(01200, 02450)

项目号/ PROJECT NUMBER	EU2101	材料/MATERIAL	N/A				
公差除表另外指定 尺寸公差参考 ISO 2768 T1-m, 形位公差参考 ISO 2768 T2-K. Unless otherwise specified, General tolerance refer: ISO 2768 T1-m, Geometrical tolerance refer: ISO 2768 T2-K 除非特别指定, 尺寸单位为 mm. Dimensions are shown in mm. Unless otherwise specified.	表面处理/FINISH	N/A					
设计/DESIGN	日期/DATE	审核/APPROVED BY	名称/DESCRIPTION				
RYAN	2024/12/9		SDA-1200/2450N ROD EYE MOUNT METRIC INSTALLATION DRAWING				
This drawing is the property of Maxcess. It is loaned with the understanding that it may not be reproduced nor may the information contained herein be used for the making of drawings or for manufacturing purposes without the written consent of Maxcess.		第一角画法/FIRST ANGLE PROJECTION	图纸大小/SIZE	比例/SCALE	图纸编号/DRAWING NO.	版本/REV	页码/PAGE
			A3	1:2	620001602-004	V11	1/1

Building 4, No. 4333  
Zuhai Avenue,  
Nanping town,  
Xiangzhou District,  
Zuhai, Guangdong,  
China, 519060.  
www.maxcessintl.com  
400-830-1898

**MAXCESS**  
Maxcess(Zuhai)Industrial Automation Equipment Co.,Ltd

REV	SYM	DESCRIPTION	DATE	BY
V10		RELEASE	2024/06/05	RYAN
V11		ADD M6 HOLE, DIMENSION UPDATE	2024/12/09	RYAN



STANDARD STROKES:

THRUST FORCE	STROKE	'A'	'B'
1200N	50	427.2	255.6
	100	502.2	305.6
	125	539.7	330.6
	150	577.2	355.6
	200	652.2	405.6
	250	727.2	455.6
	300	802.2	505.6
2450N	50	456.2	284.6
	100	531.2	334.6
	125	568.7	359.6
	150	606.2	384.6
	200	681.2	434.6
	250	756.2	484.6
	300	831.2	534.6
400	981.2	634.6	

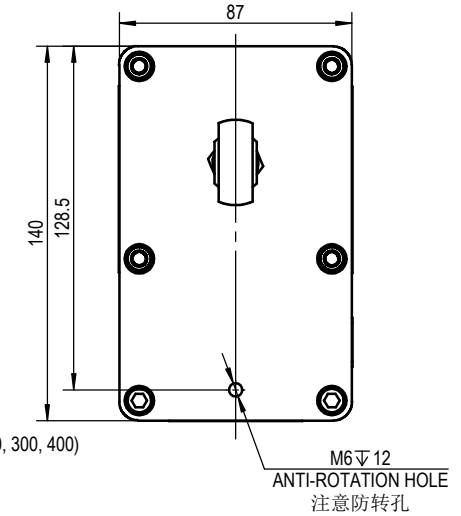
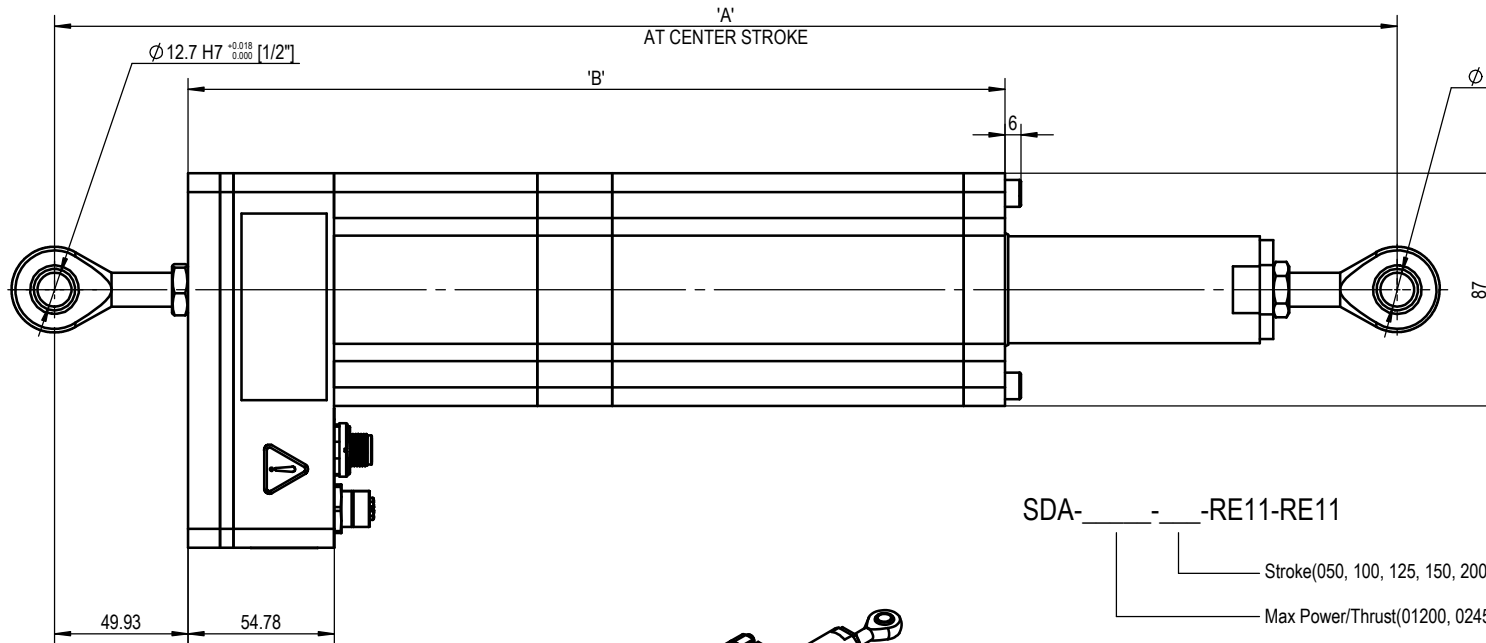

SDA- - -RE11-RE11

Stroke(050, 100, 125, 150, 200, 250, 300, 400)

Max Power/Thrust(01200, 02450)

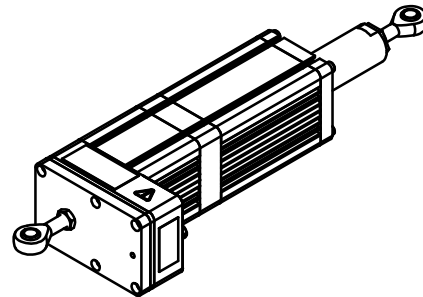

项目号/ PROJECT NUMBER	EU2101	材料/MATERIAL	N/A			
公差除表外指定 尺寸公差参考 ISO 2768 T1-m, 形位公差参考 ISO 2768 T2-K. Unless otherwise specified, General tolerance refer: ISO 2768 T1-m, Geometrical tolerance refer: ISO 2768 T2-K 除非特别指定, 尺寸单位为 mm. Dimensions are shown in mm. Unless otherwise specified.	表面处理/FINISH	N/A				
	设计/DESIGN	日期/DATE	名称/DESCRIPTION			
	RYAN	2024/12/9	SDA-1200/2450N			
审核/APPROVED BY		ROD EYE MOUNT INCH INSTALLATION DRAWING				
第一角画法/FIRST ANGLE PROJECTION	图纸大小/SIZE	比例/SCALE	图号/DRAWING NO.	版本/REV	页码/PAGE	
	A3	1:2	620001602-005	V11	1/1	



Building 4, No. 4333  
Zhuhai Avenue,  
Nanping town,  
Xiangzhou District,  
Zhuhai, Guangdong,  
China, 519060.  
www.maxcessintl.com  
400-830-1898

Maxcess(Zhuhai)Industrial Automation Equipment Co.,Ltd

SDA- - -FL01-

Rod End Mounting Type(CL01, CL11, RE01, RE11)  
 Stroke(050, 100, 125, 150, 200, 250, 300, 400)  
 Max Power/Thrust(01200, 02450)

REV	SYM	DESCRIPTION	DATE	BY
V10		RELEASE	2024/06/05	RYAN
V11		IEWS UPDATE	2024/12/09	RYAN

STANDARD SROKES:

THRUST FORCE	STROKE	'B'
1200N	50	243.6
	100	293.6
	125	318.6
	150	343.6
	200	393.6
	250	443.6
	300	493.6
2450N	400	593.6
	50	272.6
	100	322.6
	125	347.6
	150	372.6
	200	422.6
	250	472.6
300	522.6	
400	622.6	

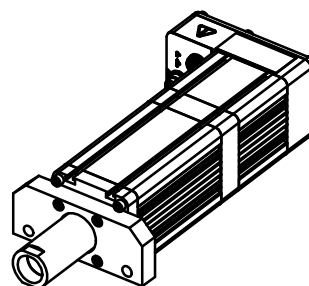
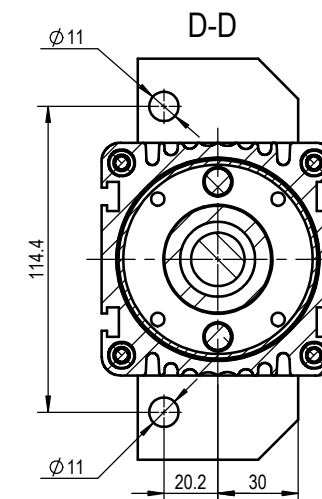
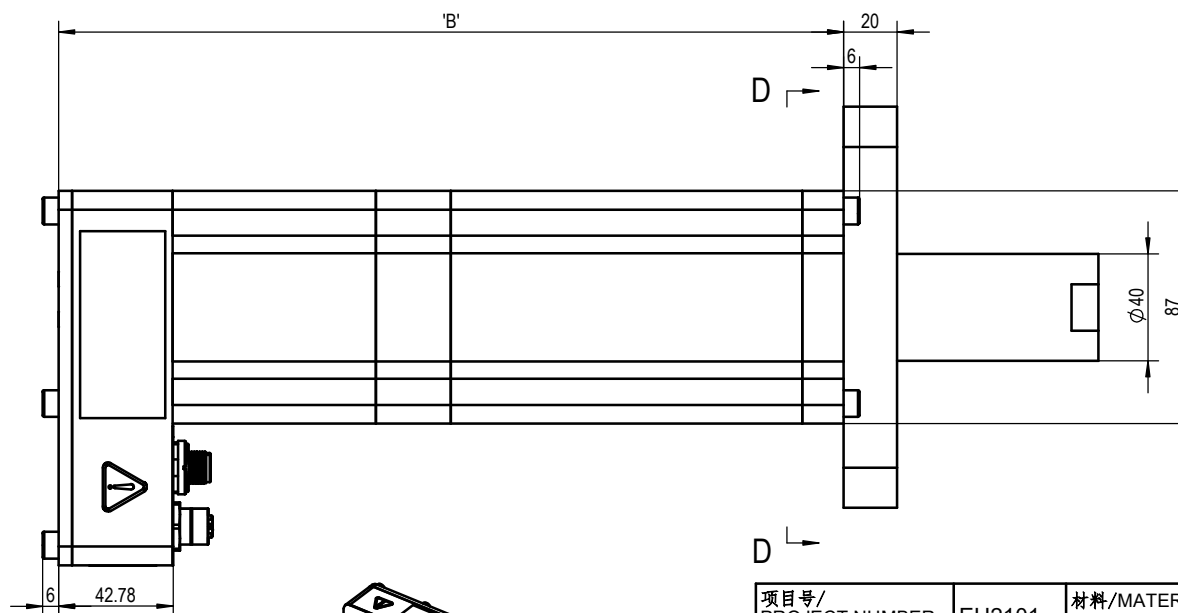
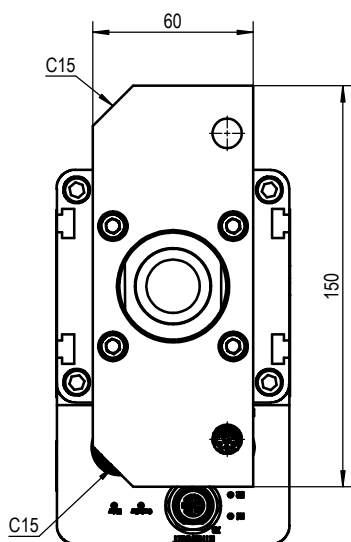
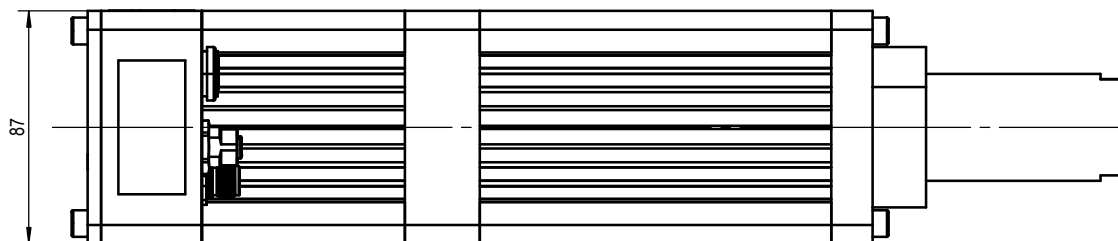

项目号/ PROJECT NUMBER		EU2101		材料/MATERIAL		N/A		 Building 4, No. 4333 Zuhai Avenue, Nanting town, Xiangzhou District, Zuhai, Guangdong, China, 519060. www.maxcessintl.com 400-830-1898	
公差除表外指定 尺寸公差参考 ISO 2768 T1-m, 形位公差参考 ISO 2768 T2-K. Unless otherwise specified, General tolerance refer: ISO 2768 T1-m, Geometrical tolerance refer: ISO 2768 T2-K 除非特别指定, 尺寸单位为 mm. Dimensions are shown in mm. Unless otherwise specified.		表面处理/FINISH		N/A		设计/DESIGN			
This drawing is the property of Maxcess. It is loaned with the understanding that it may not be reproduced nor may the information contained herein be used for the making of drawings or for manufacturing purposes without the written consent of Maxcess.		RYAN		2024/12/9		审核/APPROVED BY		名称/DESCRIPTION	
第一角画法/FIRST ANGLE PROJECTION		图幅大小/SIZE		比例/SCALE		图幅编号/DRAWING NO.		版本/REV	
		A3		1:2		620001602-006		V11 1/1	

REV	SYM	DESCRIPTION	DATE	BY
V10		RELEASE	2024/06/05	RYAN
V11		DIMENSION UPDATE	2024/12/09	RYAN

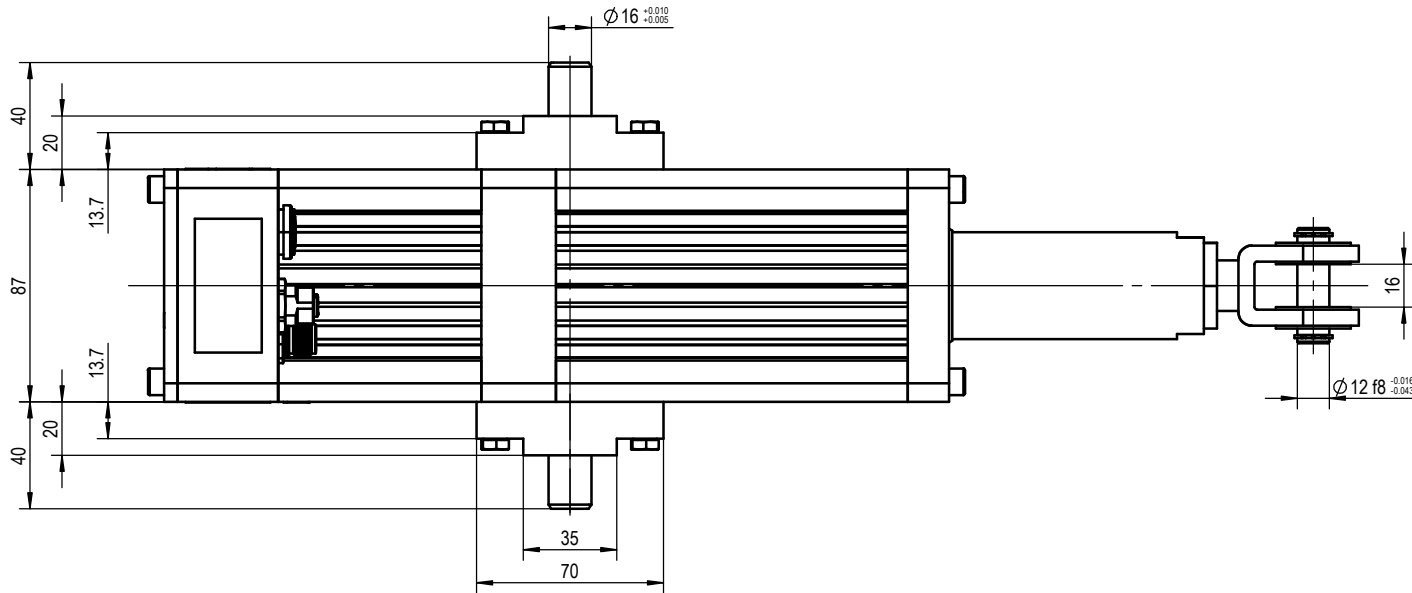

STANDARD STROKES:

THRUST FORCE	STROKE	'A'	'B'
1200N	50	354.9	243.6
	100	429.9	293.6
	125	467.4	318.6
	150	504.9	343.6
	200	579.9	393.6
	250	654.9	443.6
2450N	300	729.9	493.6
	400	879.9	593.6
	50	383.9	272.6
	100	458.9	322.6
	125	496.4	347.6
	150	533.9	372.6
200	608.9	422.6	
250	683.9	472.6	
300	758.9	522.6	
400	908.9	622.6	

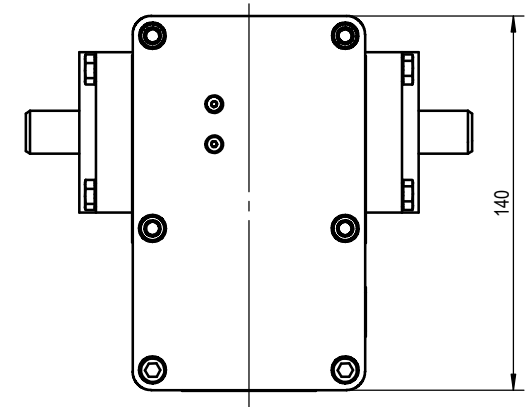
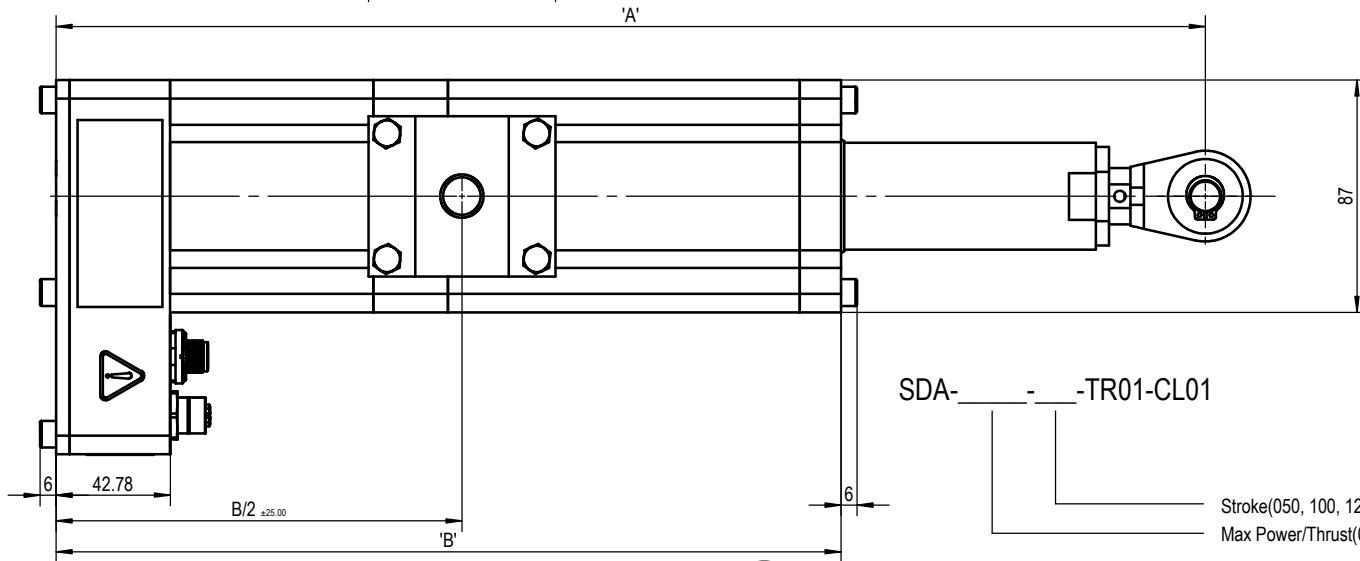

SDA- - -TR01-CL01

Stroke(050, 100, 125, 150, 200, 250, 300, 400)  
Max Power/Thrust(01200, 02450)

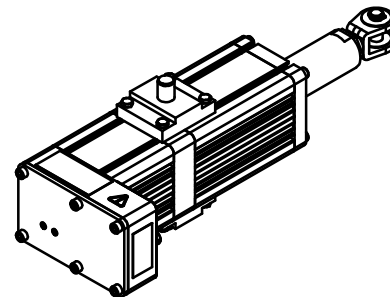

项目号/ PROJECT NUMBER	EU2101	材料/MATERIAL	N/A			
公差除单另外指定 尺寸公差参考 ISO 2768 T1-m, 形位公差参考 ISO 2768 T2-K. Unless otherwise specified, General tolerance refer: ISO 2768 T1-m, Geometrical tolerance refer: ISO 2768 T2-K 除非特别指定, 尺寸单位为 mm. Dimensions are shown in mm. Unless otherwise specified.	表面处理/FINISH	N/A				
设计/DESIGN	日期/DATE	名称/DESCRIPTION	SDA-1200/2450N			
RYAN	2024/12/9	TRUNNION & CLEVIS MOUNT METRIC INSTALLATION DRAWING				
审核/APPROVED BY			图框大小/SIZE	比例/SCALE	图框编号/DRAWING NO.	
第一角画法/FIRST ANGLE PROJECTION			A3	1:2	620001602-007	
This drawing is the property of Maxcess. It is loaned with the understanding that it may not be reproduced nor may the information contained herein be used for the making of drawings or for manufacturing purposes without the written consent of Maxcess.		版本/REV	页次/PAGE			
		V11	1/1			

Building 4, No. 4333  
Zhuhai Avenue,  
Nanping town,  
Xiangzhou District,  
Zhuhai, Guangdong,  
China, 519060.  
www.maxcessintl.com  
400-830-1898

**MAXCESS**  
Maxcess(Zhuhai)Industrial Automation Equipment Co.,Ltd

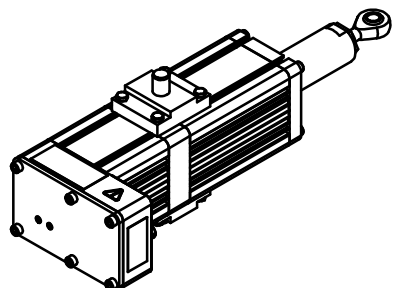
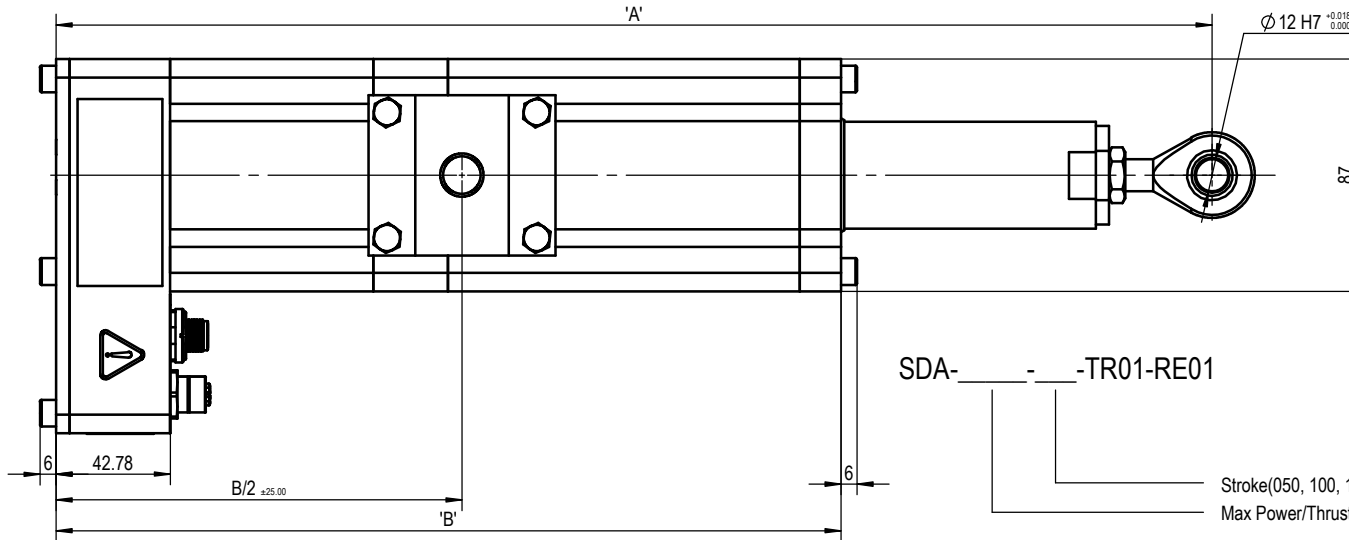
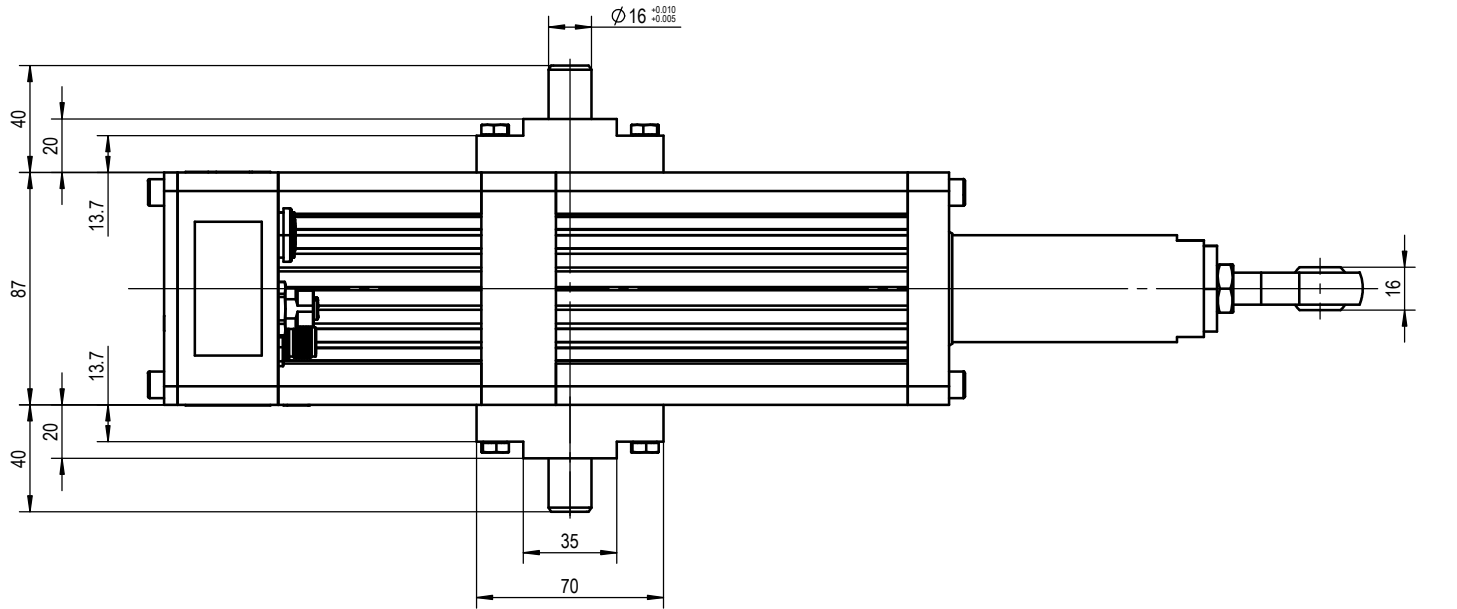

SDA- - -TR01-RE01

Stroke(050, 100, 125, 150, 200, 250, 300, 400)  
Max Power/Thrust(01200, 02450)

REV	SYM	DESCRIPTION	DATE	BY
V10		RELEASE	2024/06/05	RYAN
V11		DIMENSION UPDATE	2024/12/09	RYAN

STANDARD STROKES:

THRUST FORCE	STROKE	'A'	'B'
1200N	50	357.4	243.6
	100	432.4	293.6
	125	469.9	318.6
	150	507.4	343.6
	200	582.4	393.6
	250	657.4	443.6
2450N	50	386.4	272.6
	100	461.4	322.6
	125	498.9	347.6
	150	536.4	372.6
	200	611.4	422.6
	250	686.4	472.6
300	761.4	522.6	
400	911.4	622.6	

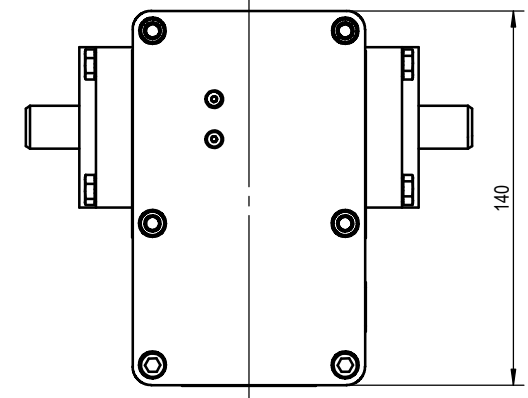

项目号/ PROJECT NUMBER EU2101		材料/MATERIAL N/A		Building 4, No. 4333 Zhuhai Avenue, Nanping town, Xiangzhou District, Zhuhai, Guangdong, China, 519060. www.maxcessintl.com 400-830-1898	
公差除单另外指定 尺寸公差参考 ISO 2768 T1-m, 形位公差参考 ISO 2768 T2-K. Unless otherwise specified, General tolerance refer: ISO 2768 T1-m, Geometrical tolerance refer: ISO 2768 T2-K 除非特别指定, 尺寸单位为 mm. Dimensions are shown in mm. Unless otherwise specified.		表面处理/FINISH N/A		Maxcess(Zhuhai)Industrial Automation Equipment Co.,Ltd	
设计/DESIGN RYAN		日期/DATE 2024/12/9		名称/DESCRIPTION SDA-1200/2450N	
审核/APPROVED BY		第一角画法/FIRST ANGLE PROJECTION		TRUNNION & ROD EYE MOUNT METRIC INSTALLATION DRAWING	
图纸大小/SIZE A3		比例/SCALE 1:2		图框编号/DRAWING NO. 620001602-008	
版本/REV V11		页次/PAGE 1/1			