

INSTRUCTION MANUAL MODEL DTR DIGITAL TENSION READOUT

All of the information herein is the exclusive proprietary property of Maxcess International, and is disclosed with the understanding that it will be retained in confidence and will neither be duplicated nor copied in whole or in part nor be used for any purpose other than for which disclosed.

Copyright 2008, all rights reserved.

Periodically there will be updates to this manual. The latest version is available at www.magpowr.com or by calling 1-800-MAGPOWR (624-7697).

1.0 INTRODUCTION

The MAGPOWR Model DTR Digital Tension Readout displays the tension in a moving web or strand in any user chosen units. Use the DTR with MAGPOWR web tension sensor(s) and interconnection cable(s). Use the DTR with tension sensor(s) on any non-driven idler roll upon which the wrap angle of the web does not change.

Each tension sensor contains four foil type strain gages in a full Wheatstone bridge configuration. These gages convert the load on the sensor to an electrical signal. The DTR amplifies and displays the electrical signal in proportion to any units chosen by the user. The DTR also provides a 0 to 10 vdc output proportional to tension, for use by a remote device. This signal is available at the "+OUT" and "GND" terminals on the rear of the DTR.

2.0 INSTALLATION

Slide the rear of the DTR through a 1/8 DIN cutout in a panel. See Figure 1 for cutout dimensions. Attach the two mounting screw brackets provided by inserting them into the recessed cavities on opposite sides of the DTR and sliding them towards the rear until they stop. Tighten the mounting screws against the backside of the panel until the DTR is secure.

Use the DTR at any ambient temperature between 0 and 40°C (32-104°F)

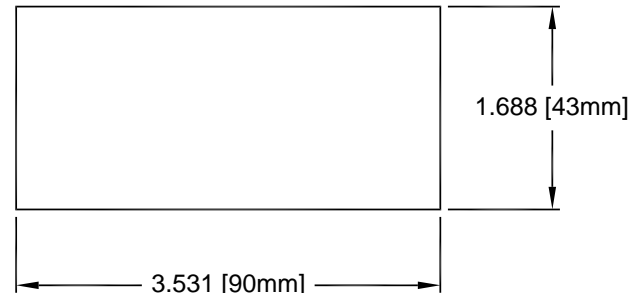

Figure 1 – DTR Panel Cutout

2.2 Power

Set the VOLTAGE SELECT switch on the rear panel of the DTR to match the ac supply voltage being used, "115V" or "230V". The DTR can also be set for a 100/200 vac supply. (See section 3.3)

2.3 Connections

Connect the DTR as shown.

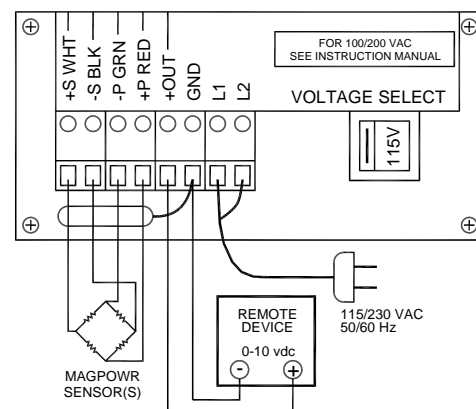

Figure 2 – DTR Wiring

2.4 Display Format

Turn on power to the DTR. Pry off the bezel and use a piece of tape or a sharp implement to remove the nameplate from the front of the DTR. Move the small switches labeled “4”, “3”, or “2” to light one of the decimal points (DP) and/or “0” as needed.

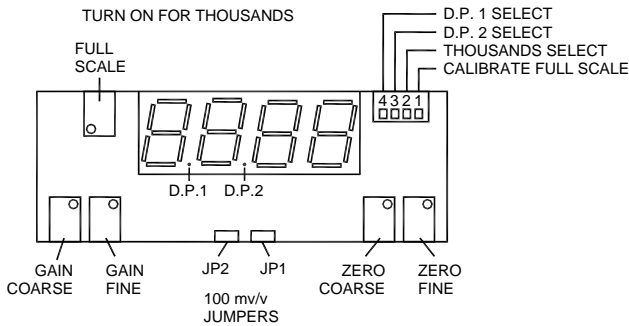

Figure 3 – DTR Front View (without cover)

2.4 Calibrate FULL SCALE

Move the switch labeled “1” to its upward position. Turn the adjustment screw marked “FULL SCALE” until the display shows the expected maximum tension (full scale) value. The output is now set to 10 vdc at this tension. Now move the switch to its downward position.

2.5 Calibrate NULL and GAIN

First unload the sensing roll by removing the web from the roll. Adjust the potentiometer marked “COARSE ZERO” or the potentiometer marked “FINE ZERO” until a zero reading is displayed. Next load the sensing roll by hanging a known weight at the end of a temporary web threaded in the normal web path and in the center of rolls. (a rope is OK) Adjust the “COARSE GAIN” or the “FINE GAIN” until the required reading is displayed. See Fig. 4.

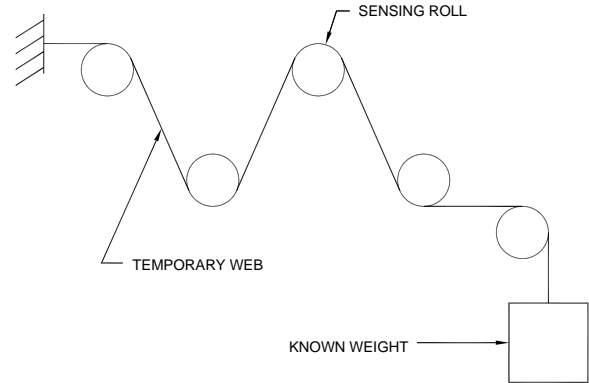

Figure 4 – Temporary Web

Remove the weight and the temporary web. Calibration is now complete, you may now web up the machine and run. Use the white rectangle on the front panel to designate units such as lb or kg.

3.0 OPTIONS

3.1 Output Voltage Calibration

If a more accurate output voltage calibration is required, use a digital multimeter to read the DTR output voltage during the following procedure. With the calibration of section 2.4 and 2.5 completed and the temporary web and known weight still in place, use the formula below to calculate the correct meter reading with the known weight applied.

T_{cal} = Known Weight
 T_{max} – Maximum Tension

$$\frac{T_{cal}}{T_{max}} \times 10 = \text{Meter Reading (vdc)}$$

Adjust coarse and/or fine gain until your digital multimeter reads the calculated voltage.

Now adjust the FULL SCALE potentiometer until the DTR reads the known weight. Calibration is complete. Remove the digital multimeter and temporary web, and operate the machine.

3.2 AC Voltage Selection

The DTR may be operated on any line voltage from 90 to 126 vac or 180 to 250 vac and either 50 or 60 Hz. To adjust the input voltage to 100/200, with all wire removed from the DTR terminal block, remove the 4 screws, lift the rear panel and slide the p.c.b. assembly out the rear.

Adjust the jumpers JP4 and JP5 and the voltage selector switches per Figure 5. Replace p.c.b., rear panel and screws.

3.3 Output Polarity

The DTR has available a 0 to 10 vdc signal proportional to tension for connection to auxiliary equipment. The DTR is shipped configured for 0 to +10 vdc output with the jumper on JP3 on pins 2 and 3.

For 0 to -10 vdc output move jumper on JP3 to pins 1 and 2. Refer to Figure 5 below.

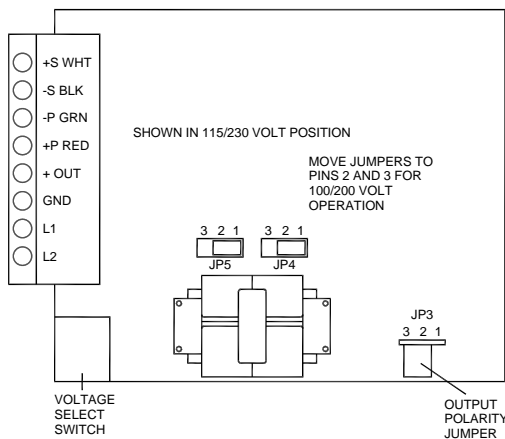

Figure 5 – DTR Printed Circuit Board

3.4 Using Non-MAGPOWR Tension Sensors

The DTR is shipped configured for use with MAGPOWR sensors or other sensors excited by a 10 volt supply and with an output of 2.1 mv/v.

The DTR may be set up to use a sensor excited by a +5 volt supply and an output of 100 mv/v by cutting jumpers JP1 and JP2 and connecting the sensors as shown in Figure 6. Refer to Figure 3 for location of JP1 and JP2.

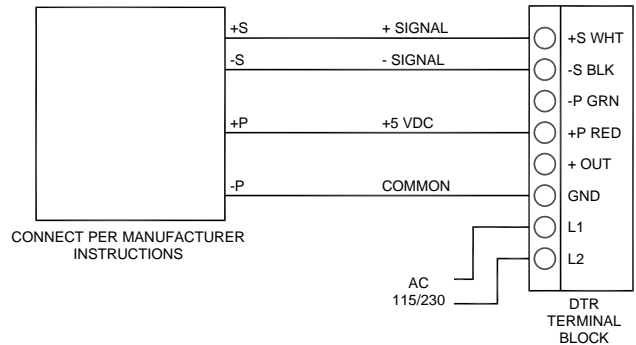

Figure 6 – Non-MAGPOWR Connections

4.0 Calibration Description

The DTR calibration is accomplished by three adjustments. FULL SCALE, GAIN, and ZERO.

The FULL SCALE adjustment sets the digital meter reading that will occur when the auxiliary output is at 10 volts.

The GAIN adjustment is made with a known weight on the sensing roll, allowing the user to calibrate the meter to his tensions. The GAIN adjustment can give the FULL SCALE reading (10 volts output) with as little as 1/8th the sensor rating.

The ZERO adjustment is used to cancel the weight of the sensing roll giving a zero reading on the meter with zero tension. The ZERO adjustment will cancel sensing roll weight up to 50% of the combined sensor rating.

5.0 SPECIFICATIONS

Power:	115/230 vac \pm 10%, 50/60 Hz, 6 Watts Optional 100/200 vac, internally set
Tension Output:	0 to +10 vdc or 0 to -10 vdc
Max Load:	1 milliamp
Operating Temperature:	0 to 40°C
Storage Temperature:	-30 to 65°C
Fuse:	1/2 amp Bussmann type GDB-0.5A
Meter:	4 digit LED display
Resolution:	3 digits
Excitation:	+ and – 5 vdc (10v) capable of driving two 350 ohm tension sensors, or +5 vdc capable of driving one 100 ohm full bridge.
Sensor Input:	
Ranges:	2.1 mv/v, or 100 mv/v.
Accuracy:	Maximum Null drift 0.005% / °C Maximum Gain drift 0.02% / °C



MAXCESS INTERNATIONAL COMPANIES



GUIDING · INSPECTION



TENSION CONTROL



SLITTING · WINDING

FIFE CORPORATION

222 W. Memorial Road, Oklahoma City, OK 73114-2317, USA / Post Office Box 26508, Oklahoma City, OK 73126-0508, USA
Phone: 405.755.1600 / 800.639.3433 / Fax: 405.755.8425 / E-mail: fife@fife.com / Web: www.fife.com